

Reference Manual



N74 ENGINE



Technical Training

The information contained in this manual is not to be resold, bartered, copied or transferred without the express written consent of BMW of North America, LLC ("BMW NA").

Table of Contents

N74 Engine

Subject	Page
Introduction	5
N74 Engine	5
History	6
N74 Engine Features	7
Technical Data	8
Horse Power and Torque Diagram	10
Engine Components/Systems Overview	11
Engine Identification	13
Engine designation	13
Engine identification and number	13
Engine Components	14
Engine Block	14
Cylinder Head	15
Cylinder Head Cover	15
Oil Sump	15
Crankcase Ventilation	16
Register Ventilation	18
Oil Separation	19
Crankshaft	20
Crankshaft Bearings	20
Connecting Rods	20
Pistons	20
Camshaft	20
Chain Tensioner	20
Valve Train	21
VANOS	22
Camshafts	22
Roller Cam Followers	22
Valves	22
Belt Drive	23
Oil Supply	25
Oil Circuit	25
Oil Pump	27
Pressure Limiting Valve	28
Oil Filter	28

Subject	Page
Oil Cooling	.28
Oil Spray Nozzles	.28
Oil spray nozzles for piston crown cooling	.29
Oil spray nozzles for timing chain lubrication	.29
Oil Level Measurement	.29
Engine Cooling	.30
Coolant Pumps	.32
Main coolant pump	.32
Auxiliary water pump for exhaust turbochargers	.32
Expansion Tank	.32
Charge Air Cooling	.33
Auxiliary Coolant Pump for Charge Air Cooling	.35
Charge-air Cooler	.35
Engine Control Unit	.36
Intake Air Duct	.36
Turbocharging	.37
Exhaust Turbocharger	.37
Charging Pressure Control	.39
Blow-off control	.39
Charge Air Cooling	.40
Intake Manifold	.40
Exhaust System	.41
Exhaust Manifold	.42
Exhaust Emissions	.42
Secondary Air System	.42
Secondary air pump	.42
Secondary air valve	.43
On-board diagnosis of secondary air system	.43
Vacuum System	.44
Fuel Injection	.46
High Pressure Pump	.48
Hydraulic Circuit Diagram	.50
Injectors	.51
Outward-opening Piezo Injector	.51
Control Unit	.51

**BLANK
PAGE**

N74 Engine

Model: F01/F02

Production: From Start of Production

OBJECTIVES

After completion of this module you will be able to:

- Describe the features of the N74B60U0 engine
- Describe the specifications of the N74 engine
- Identify the internal and external components of the N74 engine

Introduction

N74 Engine

The N74 engine is the successor to the N73 engine, but shares many technical features with the N63 engine. Thus the N74 engine also has high precision injection featuring outward-opening piezo injectors located centrally in the combustion chamber and twin turbochargers with indirect charge air cooling. On the N74 engine, however, the exhaust turbochargers are located on the outside of the engine.

N74B60U0 engine



Models with the N74 engine were launched to the US market in the September 2009.

Model	Model series	Engine	Power output in kw/bhp	Torque in Nm
760i	F01	N74B60U0	400/535	750
760Li	F02	N74B60U0	400/535	750

History

The following chart list all previous BMW Twelve-cylinder gasoline engines.

Engine	Model	Model series	Displacement in cm ³	Power output in kW/ bhp	Torque in Nm	Engine control system	Introduced-discontinued
M70B50	750i	E32	4988	220/300	450	ME1.2	5/87-9/90
M70B50	850i	E31	4988	220/300	450	ME1.7	4/90-11/94
M70B50	750i	E32	4988	220/300	450	ME1.7	9/90-11/94
S70B56	850Csi	E31	5576	208/381	550	ME1.7.1	10/92-9/97
M73B54	750i	E32	5379	240/326	490	ME5.2	9/94-9/01
M73B54	850Ci	E31	5379	240/326	490	ME5.2	9/94-9/99
N73B60	760i	E65	5972	327/445	600	MED9.2.1 + HPFI	9/02-9/08
N73B60	760Li	E66	5972	327/445	600	ED9.2.1 + HPFI	9/02-9/08

N74 Engine Features

The N74 engine also shares many other common features with the N63 engine, such as a volumetric-flow-controlled oil pump and a camshaft drive with tooth-roller type chains.

By using the latest technology, it has been possible to increase power output substantially, while at the same time reducing fuel consumption – Efficient Dynamics in fact.



Index	Explanation
1	Camshaft drive with tooth-roller type chain
2	High pressure pump for high precision injection
3	Charge air cooling for indirect charge air cooling
4	Outward-opening piezo injector
5	Volumetric-flow-controlled oil pump
6	Exhaust turbocharger
7	Charging pressure control by means of wastegate valves

Technical Data

		N73B60O1	N74B60U0
Type		V12 60°	V12 60°
Firing order		1-7-5-11-3-9- 6-12-2-8-4-10	1-7-5-11-3-9- 6-12-2-8-4-10
Displacement	[cm ³]	5972	5972
Bore / stroke	[mm]	89/80	89/80
Power output at engine speed	[kW/bhp] [rpm]	320/435 6000	400/535 5250-6000
Torque at engine speed	[Nm/lb-ft] [rpm]	600/400 3950	750/550 1500-5000
Power output per liter	[kW/l]	53.58	66.98
Cutoff speed	[rpm]	6500	6500
Compression ratio		11.5	10.0
Maximum Boost	bar	NA (Naturally Aspirated)	0.7
Distance between cylinders	[mm]	98	98
Valves per cylinder		4	4
Diameter of intake valve	[mm]	35.0	33.2
Diameter of exhaust valve	[mm]	29	29
Diameter of main bearing journals of the crankshaft	[mm]	70	65

		N73B6001	N74B60U0
Diameter of connecting rod bearing journals of the crankshaft	[mm]	54	54
Fuel specification	[RON]	98	95
Fuel	[RON]	91-98	91-98
Engine control system		2 x MED 9.2.1 1 x VALVETRONIC control unit 2 high-pressure fuel injection valve control units (HPFI)	2 x MSD87-12
Exhaust emission standard US		LEVII	ULEV II

Horse Power and Torque Diagram

Full load diagram for the N74B60 engine, compared with the N73B60 and N63B44 engines

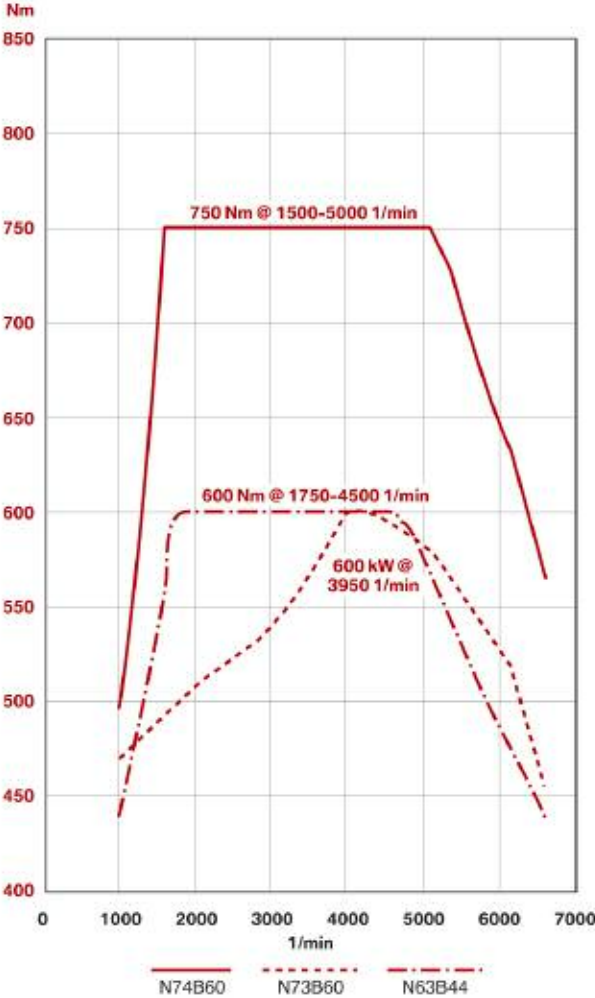
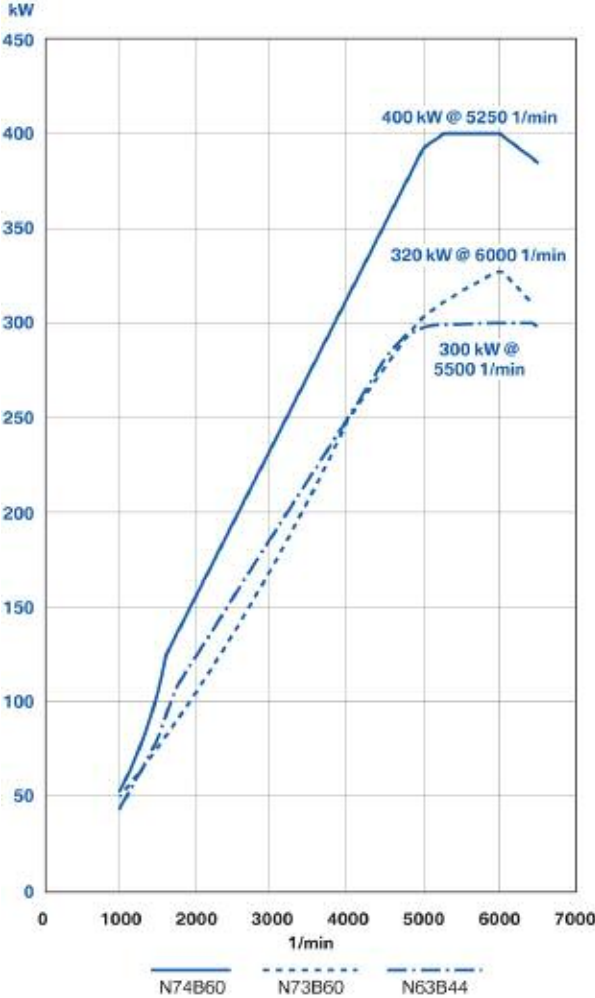

Engine Components/Systems Overview

The following provides an overview of the features of the N74 engine:

- **Engine block**

The main components of the engine block have been re-designed, although most features are already used on other BMW engines.

- **Crankshaft**

Although the Pistons and connecting rods have been borrowed from the N63 engine, the crankshaft is a new design.

- **Valve train**

The VANOS units from the N63 engine are used and the camshafts are manufactured in the same way. The N74 does not use a VALVETRONIC system.

- **Camshaft**

The tooth-roller type chain of the N63 engine is used. Only the chain length and the layout of the timing gears have been adapted to suit the twelve-cylinder engine.

- **Belt drive**

The structure of the belt drive includes a “revolver” tensioning system and is identical to that on the N63 engine.

- **Oil supply**

Though the oil supply system has been designed for the N74 engine, in principle, it's the same as that on the N63 engine. Consequently a volumetric-flow-controlled oil pump is also used here.

- **Crankcase ventilation**

The engine uses the same crankcase ventilation principle as N63 engine with a new feature called register ventilation. With this feature, the oil separators now have four cyclones per cylinder bank and in naturally-aspirated operation, ventilation only occurs via cylinder bank 2.

- **Cooling system**

Two separate cooling circuits are used as on N63, one to cool the engine and turbocharger bearings and one for charge air cooling, this latter circuit also provides cooling for the two engine control units.

- **Air intake and exhaust system**

The air intake and exhaust systems are the same as that on the N63 engine. This means there are two conventional exhaust turbochargers with wastegate and blow-off valves. In contrast to the N63 engine, however, the exhaust turbochargers are located on the outside.

- **Secondary air system**

As with N73 engine, the N74 is equipped with a secondary air system. One new feature, however, are the two pressure sensors that monitor system operation.

- **Vacuum system**

The N74 engine has a two-stage vacuum pump as on the N63. The vacuum system only differs in that it has two vacuum reservoirs.

- **Fuel system**

The N74 engine uses “injection guided” (HPI) high precision injection in homogeneous operation at all times, as on the N54 and N63 engines. The structure of the system is the same as that on the N63 engine. Consequently, the same injectors are used and the high pressure pumps are also very similar.

- **Engine electrical system**

A total of five control units were used on the N73 for engine control purposes. The N74 now has two engine control units, one of which has the role of the master (primary), the other the secondary. The two MSD87-12 control units are located to the left and right of the engine compartment and are cooled by the low temperature cooling circuit of the engine intercoolers.

The N74 engine uses the most current BMW systems. Although the N74 engine has been designed from scratch, from a technology point of view it is, the same as the N63 engine and has also borrowed many individual components from this engine.

Engine Identification

■ Engine designation

In the technical documentation, the engine designation is used to ensure the clear identification of engines.

The N74 engine is available in the following version: **N74B60U0**

In the technical documentation, you will also find the short form of the engine designation N74 which only permits identification of the engine type.

The following chart explains the meaning of each component of the engine designation.

Index	Explanation
N	BMW Group "New generation"
7	12-cylinder engine
4	Engine with high precision injection and turbocharging
B	Gasoline engine
60	6.0 liters displacement
U	Lower power stage
0	New development

■ Engine identification and number

To ensure clear identification and classification, the engines have an identification mark on the crankcase. This engine identification is also necessary for approval by the authorities.

Decisive here are the first seven positions. The N74 engine has an engine identification that complies with the new standard, in which the first six positions are the same as the engine designation. The seventh position is a consecutive letter that can be used for various distinctions, e.g. power stage or exhaust emission standard. A general assignment is not possible, but an "A" usually means the basic model.

The engine number is a consecutive number that permits unmistakable identification of each individual engine. The engine designation and number are on the crankcase behind the bracket for the air conditioning compressor.

Engine Components

Engine Block

The engine block of the N74 engine is a new design. It is similar to the N63 engine concept, but with a cylinder bank angle of 60° and the following features:

- Block made of an aluminum alloy (Alusil)
- Closed deck crankcase design
- Honed cylinder liners
- Lowered side walls (deep skirt) with main bearing caps
- Double main bearing bolting with additional side wall connection.

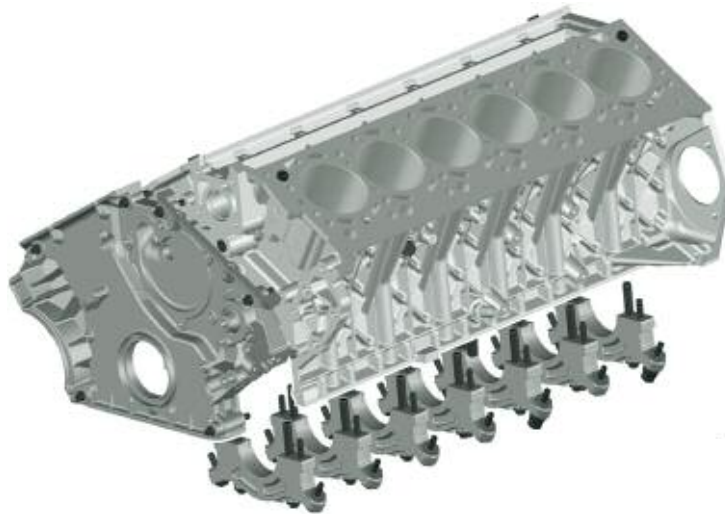

The closed-deck design and the bolt connections of the cylinder heads in the bottom of the cylinder housing ensure high rigidity and low deformation of the exposure-honed cylinder liners.

The crankcase with lowered side walls (deep skirt) has double main bearing bolting with additional side wall connections by means of threaded support sleeves and bolts designed to absorb the lateral forces from the crankshaft common on the V-engine configuration.

There are coolant passages to cool the (hot zone) area between the cylinders. In order to keep the pumping losses in the crankcase to a minimum, there are one to six ventilation holes below each of the main bearing seats.

The use of separate channels for the oil return from the cylinder heads and for crankcase ventilation reduces the amount of oil in the blow-by gases.

As on the N63 engine, the torque converter is bolted onto the flywheel through an opening in the converter housing with six bolts positioned at an angle of 30°. This makes it easier to replace the transmission.

Cylinder Head

The cylinder head features the injector and spark plugs arranged in the center of the combustion chamber. The layout of the high pressure fuel pumps is similar to that on the N63 engine; however because of the conventional cylinder head arrangement (intake side on the inside, exhaust side on the outside) they are located above the intake camshafts (respectively between cylinders 1 and 2 and 7 and 8).

As on the N63 engine, the intake port features a trailing edge (around the valve seats) for creating more intensive charge movement.

Coolant flows diagonally across the cylinder head (from the outer side of the engine towards the V chamber), whereby the inlet is at the outside rear and the outlet at the inside front. This is referred to as diagonal cooling.

As on the N63 engine, only one non-return valve for the oil circuit is incorporated into the cylinder head. The N74 uses two VANOS non-return valves, they are now integrated into the VANOS solenoid valves.

Cylinder Head Cover

The cylinder head covers are made of die-cast aluminum. They accommodate the oil separation of the crankcase ventilation. The oil separators are made of plastic and are very similar to those in the N63 engine.

Oil Sump

The engine oil sump is structured in two parts. The upper and lower sections of the die-cast aluminum oil sump have been optimized with regard to strength and acoustics. A two-part oil deflector also ensures particularly low oil foaming in extreme driving situations. A surge plate ensures that an adequate oil level is achieved in the case of high longitudinal and lateral dynamic forces.

The thermostat for the engine oil cooler as well as the oil filter with an oil filter insert made of synthetic fleece are integrated in the engine oil sump. The lower section of the oil sump contains the oil level sensor that enables electronic oil level measurement. There is no oil dipstick.

Crankcase Ventilation

Crankcase ventilation works to a large extent in the same way as on the N63 engine. However, the N74 has register ventilation, which is also used on the S63 engine.

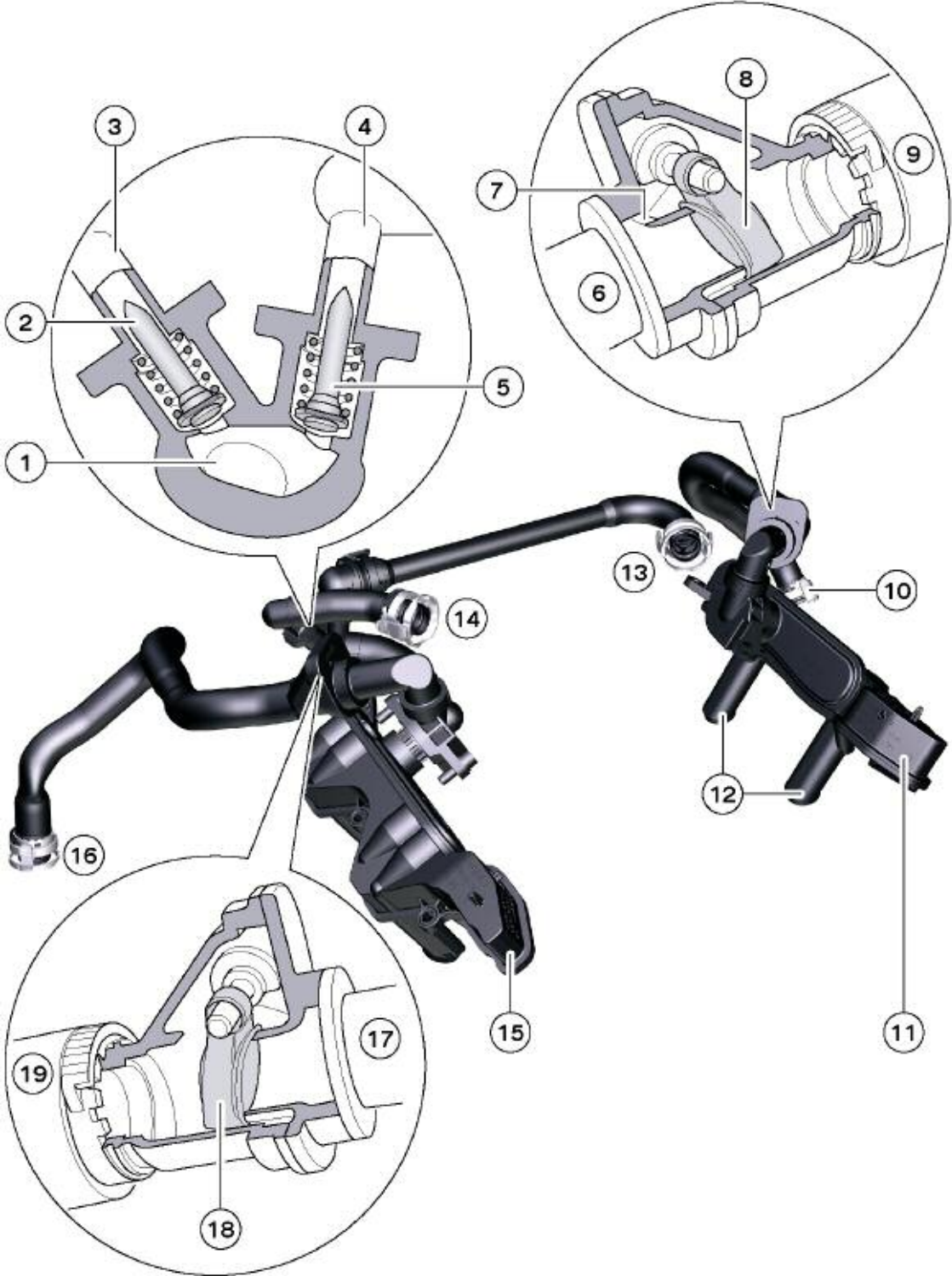

Index	Explanation
1	Inlet from oil separator, bank 2
2	Non-return valve
3	Outlet to air intake system, cylinder bank 2
4	Outlet to air intake system, cylinder bank 1
5	Non-return valve
6	Inlet from oil separator, bank 1
7	Orifice for fresh air intake (crossflow ventilation)
8	Non-return flap
9	Outlet to fresh air pipe, cylinder bank 1
10	Connection to fresh air pipe, cylinder bank 1
11	Oil separator, cylinder bank 1
12	Oil return ducts
13	Connection to air intake system, cylinder bank 1
14	Connection to air intake system, cylinder bank 2
15	Oil separator, cylinder bank 2
16	Connection to fresh air pipe, cylinder bank 2
17	Inlet from oil separator
18	Non-return flap
19	Outlet to fresh air pipe, cylinder bank 2

Each cylinder bank has its own oil separation system which includes four cyclone separators.

In naturally-aspirated mode, the cleaned blow-by gas is introduced downstream of the exhaust turbochargers through the non return valves that connect to the intake manifold.



In boost mode it is introduced upstream of the exhaust turbochargers through the non return flaps leading to the fresh air pipes on each bank. In contrast to the N63 engine, the crankcase ventilation systems for the left and right cylinder banks are **not** completely separate from each other.

Register Ventilation

Unlike the N63 engine, this engine uses register ventilation, a system that is already familiar from the S63 engine. In this system, when the engine is operating in naturally-aspirated mode, the crankcase is only ventilated via the oil separation system of cylinder bank 2 (left). As a result, the efficiency of the oil separator in partial load operation is increased.

The crankcase is crossflow ventilated by introducing fresh air via the oil separator on cylinder bank 1. Fresh air is drawn into the system through an orifice in the (bank1) non-return valve. Ventilating the crankcase with fresh air removes water and fuel components more effectively, increasing the service life of the oil and reducing the moisture in the lines. This reduces the danger of freezing, therefore the N74 engine does not require heating for the crankcase ventilation.

For normal engine operation, the crankcase ventilation ensures a vacuum of maximum 70 mbar in the crankcase. During catalytic converter heating, higher vacuum can also occur.

Oil Separation

The structure of the oil separator is also the same as that on the N63 engine. Labyrinth and cyclone oil separators are used. One labyrinth and four of the cyclones are integrated in the oil separator housing of each cylinder bank. In contrast to the N63 engine, all four cyclones are now used here.

N74 Engine Oil Separation

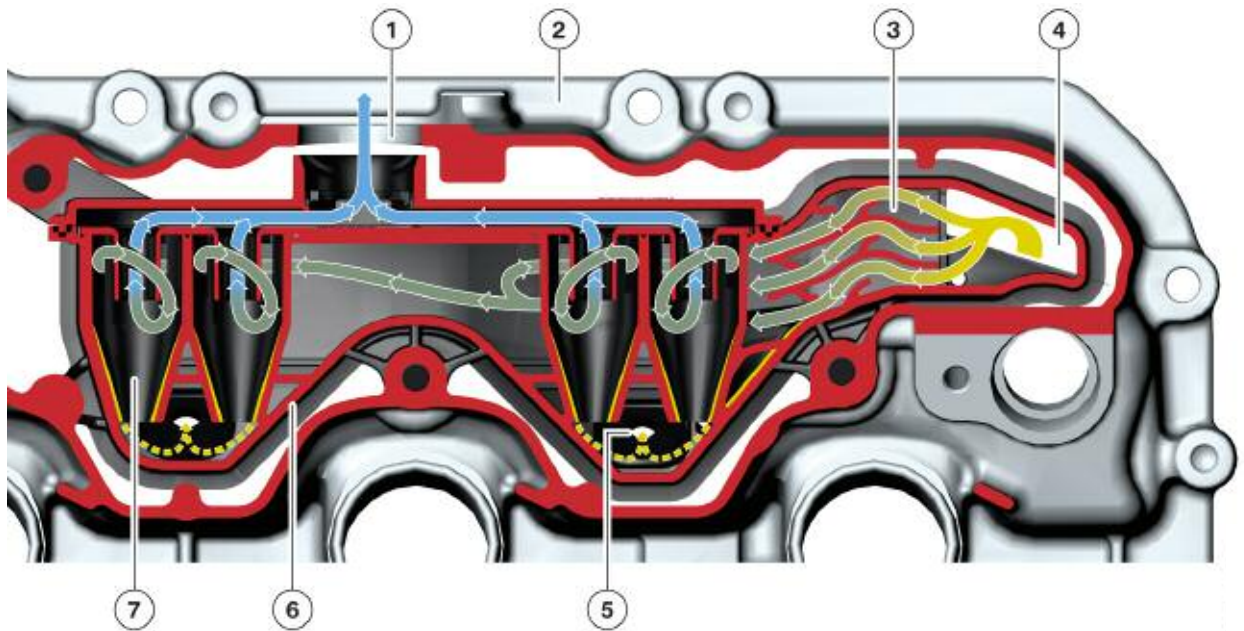

Index	Explanation
1	Duct to the intake plenum
2	Cylinder head cover
3	Labyrinth
4	Ventilation duct out of the cylinder head
5	Oil return
6	Oil separator housing
7	Cyclone

Crankshaft

This is a forged crankshaft with hardened running surfaces. A central hole through the main bearing and holes in the crank pin contribute to reducing the weight. To reduce fuel consumption, the main bearing diameters of the crankshaft have been reduced from 70 mm to 65 mm. This also enables the use of a double main bearing bolt connections without enlarging the crankcase. As on the N63 engine, the oil pump is driven on the flywheel side by the crankshaft. The camshaft sprocket is directly integrated into the crankshaft.

Crankshaft Bearings

The main crankshaft bearings are two-component bearing shells.

Connecting Rods

The cracked forged connecting rods with trapezoidal wrist pin bosses have been borrowed from the N63 engine. On the rod side, they have three-component sputter bearing shells; three-component bearing shells are fitted on the cover side.

Pistons

The Alusil cylinder bores mean the pistons are iron-coated.

Camshaft

The tooth-roller type chain, which was first introduced on the N63 engine, is used for the camshaft drive. Only its length is different. The tooth-roller type chain combines the advantages of a tooth type chain and a roller type chain to provide high resistance to wear and low noise.

The chain tensioners, tensioning rails and slide rails are common components for both cylinder banks.

In contrast to the N63 engine, the N74 engine is once again disconnected at cylinder 1 firing TDC. However, the same special tool is used to disconnect it. It is placed on the torsional vibration damper and forms the reference point for the alignment pin with respect to the crankcase.

Chain Tensioner

The hydraulic chain tensioner is a common part shared with the N63 engine. The N74 engine has a chain tensioner for each cylinder bank. It is a hydraulic chain tensioner that acts on a tensioning rail. Each one is arranged within the chain track to save space.

The oil spray nozzles for timing chain lubrication are integrated in the chain tensioners.

Note: Before removal, the chain tensioner must be fully retracted and secured with the special tool supplied for the purpose. Always follow the procedure in the repair instructions.

Valve Train

The valve opening times have been optimized with regard to the change in charging and mixture preparation.

N74 Valve Stroke Curves

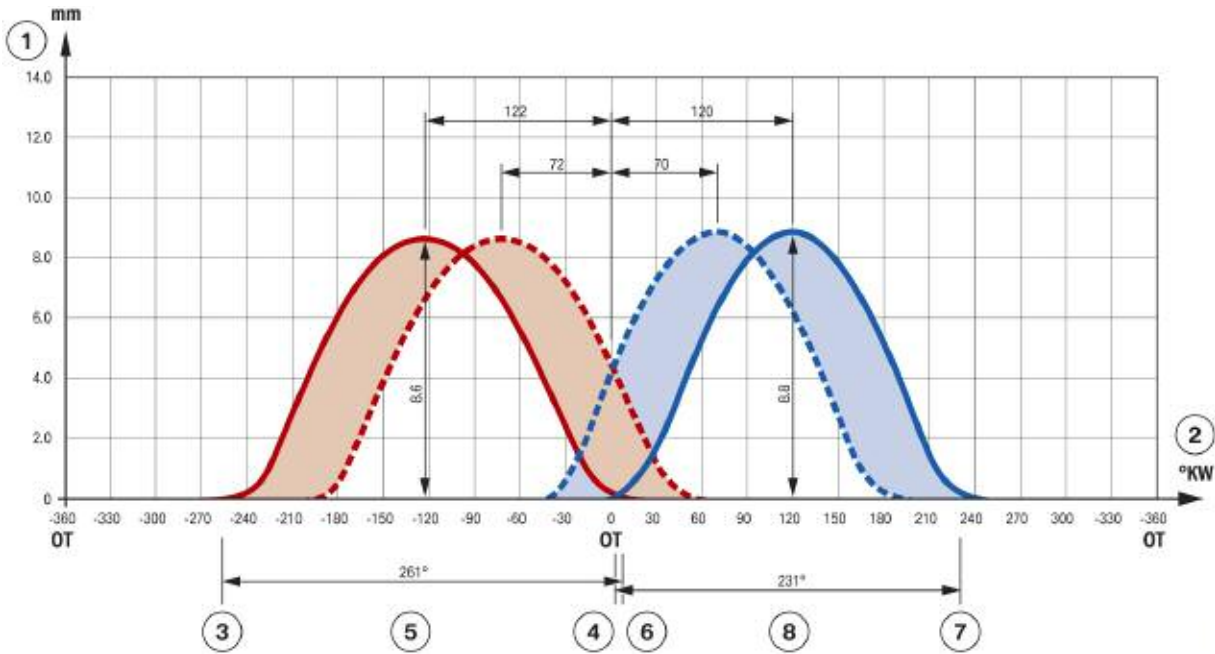

Index	Explanation
1	Valve lift [mm]
2	Crank angle [°CA]
3	Exhaust valve opens
4	Intake valve opens
5	Opening period, exhaust valve
6	Exhaust valve closes
7	Intake valve closes
8	Opening period, intake valve

VANOS

Like all current BMW gasoline engines, the N74 engine is also equipped with variable double VANOS. The VANOS units are common parts shared with the N63 engine, with the exception of the intake unit on cylinder bank though this is also designed to the same principle, it features a drive flange with a slot for the vacuum pump. The N74 uses two VANOS non-return valves, they are now integrated into the VANOS solenoid valves.

The VANOS units have the following adjustment angles:

- VANOS unit intake: 50° crank angle
- VANOS unit exhaust: 50° crank angle

Camshafts

As on the N63 engine, the camshafts are thermally jointed and have forged cams, a steel flange for the VANOS units (including width across flats and mounting flats for the special tool) and a sintered camshaft sensor wheel as reference for the camshaft position sensor. The intake camshafts each have an additional 3-way cam to drive the high pressure pumps.

Roller Cam Followers

Roller cam followers are also used in the N74 engine as transfer elements of the cam movement onto the valves. New is a directional oil splash bore hole in the contact surface of the roller cam follower on the hydraulic valve clearance compensating element. The oil from the hydraulic valve clearance compensating element splashes precisely onto the contact surface between the camshaft and roller cam follower. This supplies the roller and the cam with oil for cooling and lubrication.

N74 Roller Cam Follower Valves

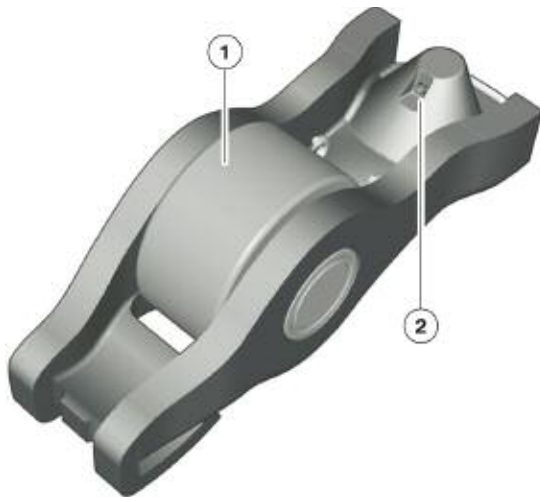

Index	Explanation
1	Roller
2	Oil splash bore hole

The exhaust valves are sodium-filled and the valve stems are not chrome-plated. The lift is 8.6mm for exhaust and 8.8 for the intake.

Belt Drive

The main belt drive, a drive belt with seven ribs, drives:

- the power steering pump
- the air-cooled 210 A alternator and
- the mechanical coolant pump.

N74 Belt Drive

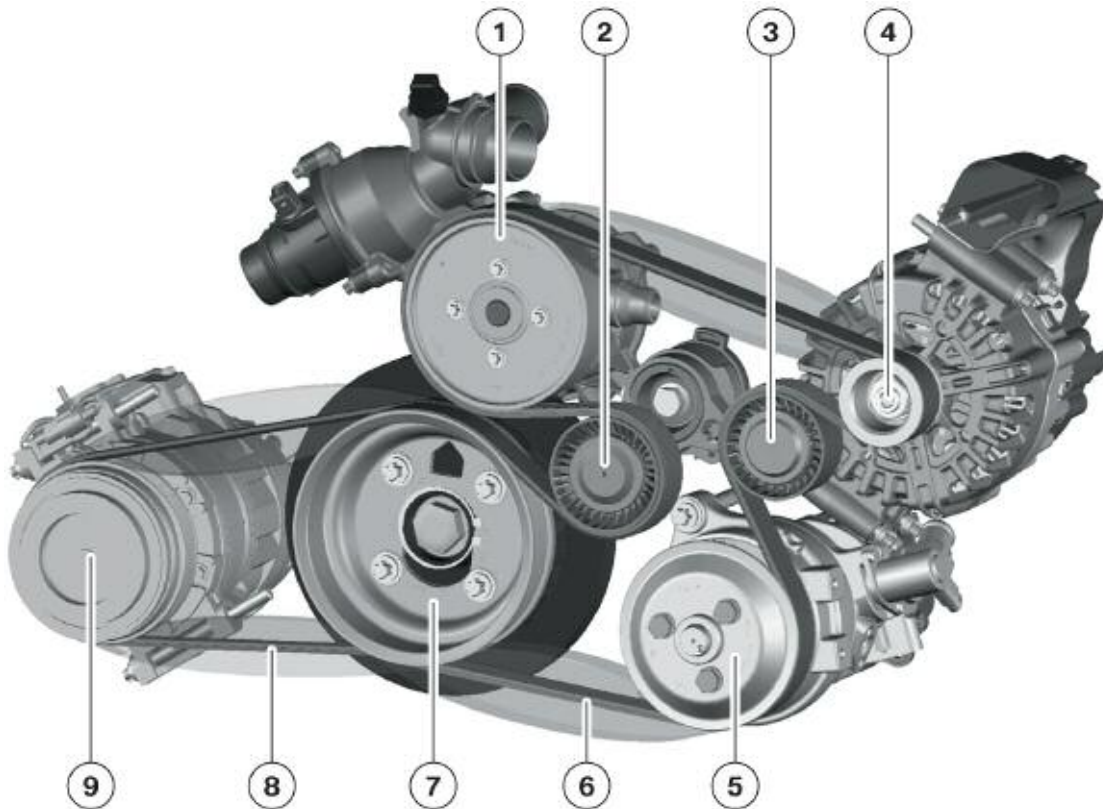

Index	Explanation
1	Coolant pump
2	Tensioning pulley
3	Deflection pulley
4	Alternator
5	Power steering pump
6	Poly-V belt
7	Belt pulley on the torsional vibration damper
8	Elastic belt
9	A/C compressor

The main belt drive has a mechanical tensioning pulley that applies the necessary tension to the poly- V belt. The use of a smooth belt pulley for the coolant pump drive enables a partial shift in the belt wear to the tips of the belt ribs. This has a positive effect on the service life of the belt.

A patented drainage system on the belt pulleys of the crankshaft and the power steering pump drains off water that may enter between the belt and pulley in the event the engine is splashed with a large amount of water or if the vehicle is driven through a puddle.

The auxiliary belt drive for the AC compressor has an elastic belt with four ribs. Using the “revolver” belt tensioning system from the N63 engine makes it possible to eliminate the tensioning pulley and related components.

The belt drive is driven by the primary side of the torsional vibration damper (harmonic balancer). The belt pulley is securely connected to the crankshaft. This is a new feature: the belt pulley is usually connected to the secondary side (the side that is flexibly connected to the crankshaft). As a general principle, it is the task of the harmonic balancer to counteract the torsional vibrations of the crankshaft. Here, the secondary side is also subjected to torsional vibrations that have a greater amplitude than those on the crankshaft.

By reducing the torsional vibrations at the drive pulley, the loads on the belts are minimized, this has a positive effect on service life.

N74 ELAST drive belt adjustment

Index	Explanation
A	Mounting position for ELAST drive belt
B	Turning torsional vibration damper for tensioning belt
C	Normal position

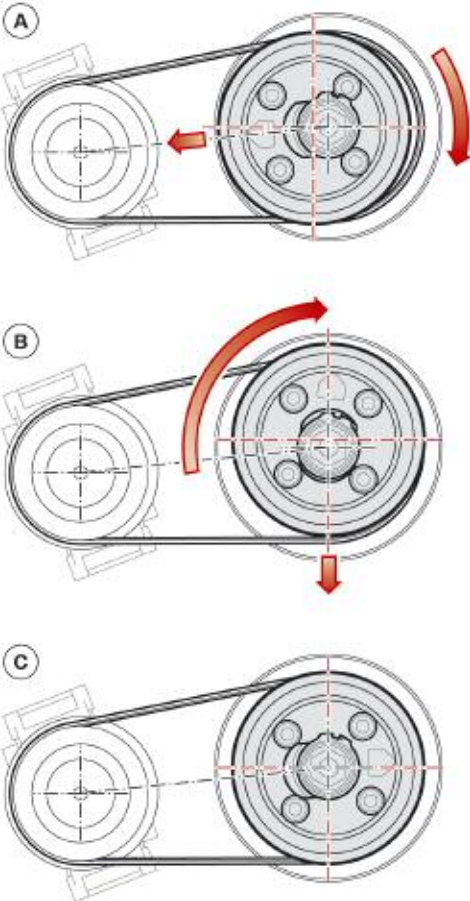

Oil Supply

Oil Circuit

N74 engine oil circuit

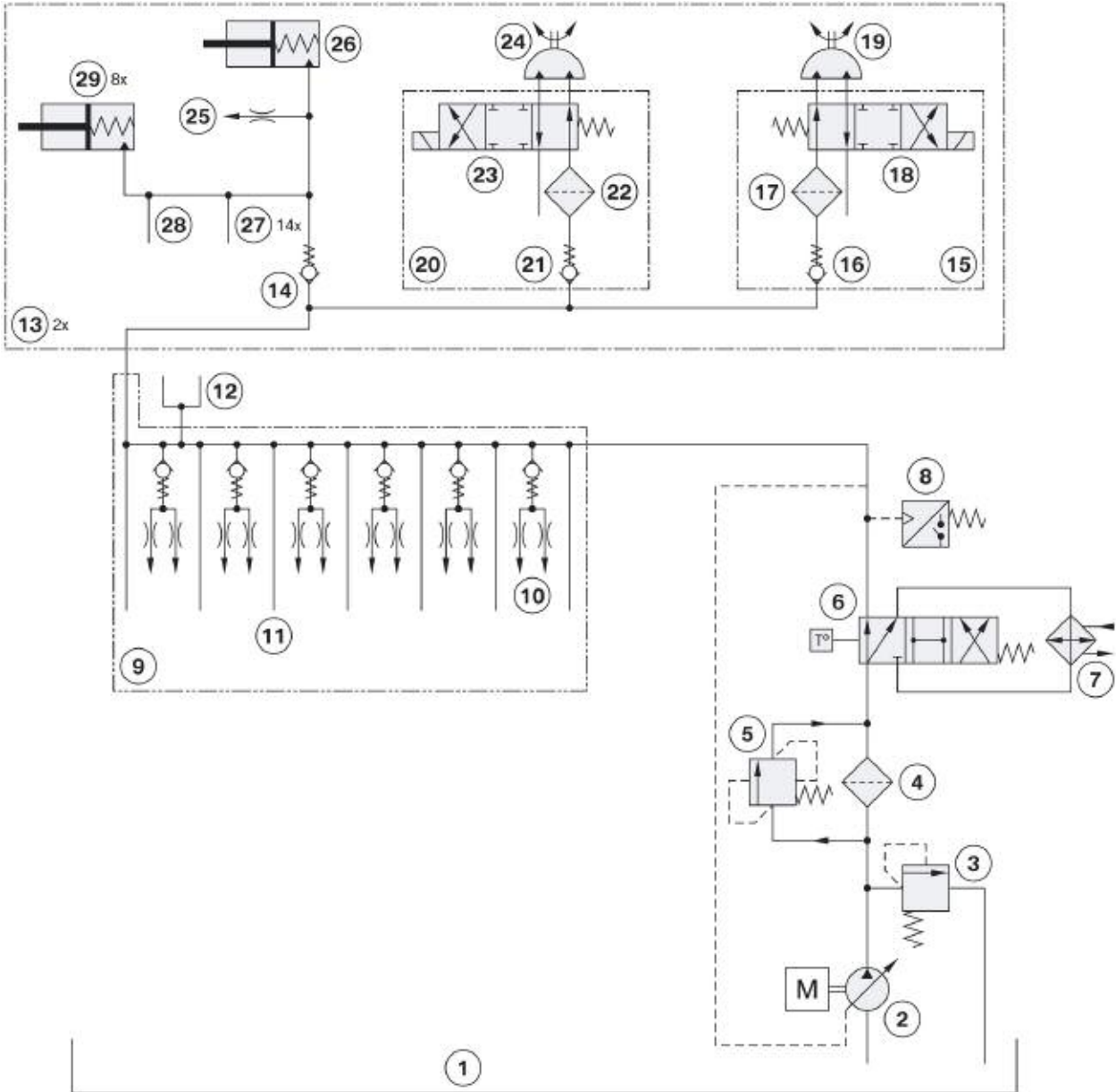

Index	Explanation
1	Oil sump
2	Volumetric-flow-controlled oil pump
3	Pressure limiting valve
4	Oil filter
5	Filter bypass valve
6	Thermostat
7	Oil cooler, oil-air heat exchanger
8	Oil pressure switch
9	Crankcase
10	Oil spray nozzles for piston crown cooling
11	Lubrication points, main crankshaft bearings
12	Lubrication points, shaft bearings of the exhaust turbochargers
13	Cylinder heads (2x)
14	Non-return valve
15	VANOS solenoid valve, intake camshaft
16	Non-return valve
17	Strainer
18	Solenoid valve
19	VANOS Unit
20	VANOS solenoid valve, exhaust camshaft
21	Non-return valve
22	Strainer
23	Solenoid valve
24	VANOS Unit
25	Oil spray nozzle for the timing chain
26	Chain tensioner
27	Lubrication points, camshaft bearings (10)
28	Lubrication points, high pressure pump
29	Hydraulic valve clearance compensating elements (8)

Oil Pump

The pendulum slide cell pump is, with the exception of the intake snorkel and the cover, identical to the oil pump in the N63 engine. On N74 it is also driven off a cast gear on the flywheel side of the crankshaft via a chain.

N74 Oil Pump

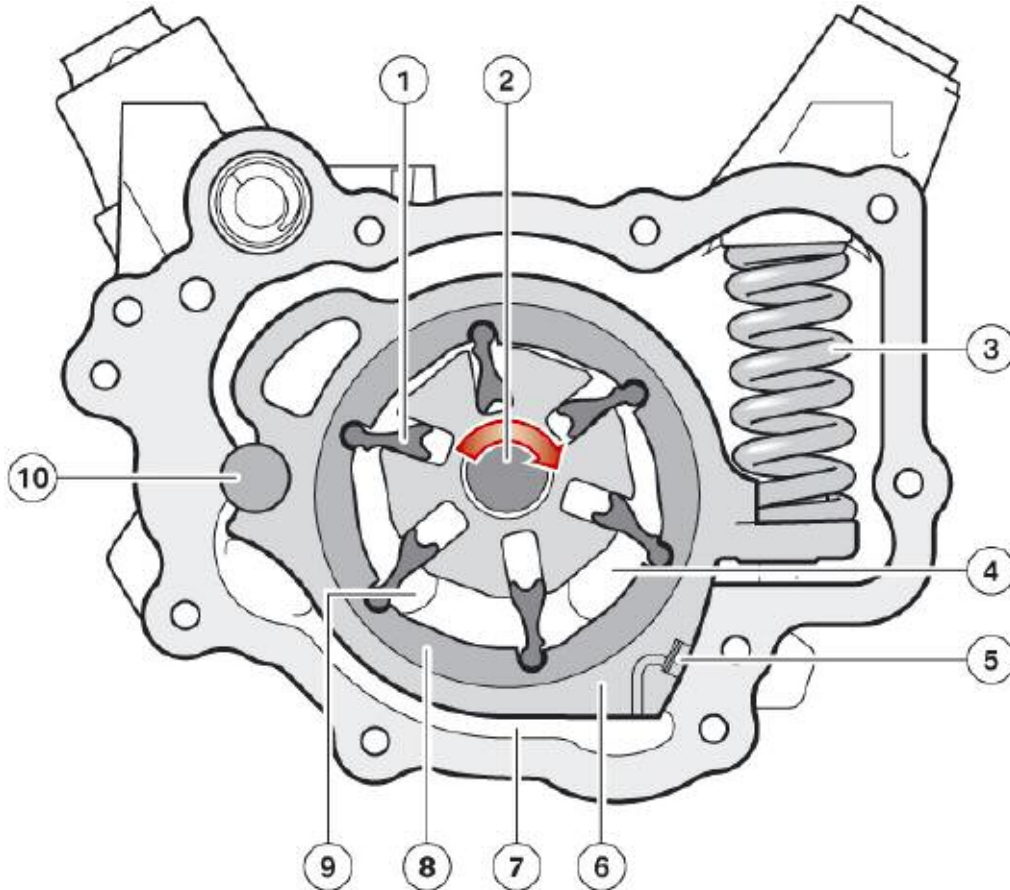

Index	Explanation
1	Vanes
2	Pump shaft
3	Compression spring
4	Intake side
5	Sealing strip
6	Pendulum slide
7	Control oil chamber
8	Rotor
9	Pressure side
10	Rotational axis

Volumetric flow control means that only the quantity of oil actually required for the respective operating condition is supplied. This reduces the amount of power required to drive the oil pump and also reduces oil wear. Regulation is achieved by utilising the pressure of the oil in the system downstream of the oil filter; the pressure acts on the pendulum slide and in so doing adjusts the delivery rate.

Pressure Limiting Valve

The pressure limiting valve is integrated into the oil pump. Pressure is applied to it upstream of the filter and it opens at a pressure of approximately 18 bar. When it opens, it releases surplus oil directly into the oil sump.

Oil Filter

The N74 engine has the usual full-flow oil filter. In the same way as the predecessor, the synthetic-fleece oil filter is bolted onto the oil sump from below. This arrangement means that neither a discharge valve nor a non-return valve is required. The filter bypass valve is located in the oil filter cover.

Oil Cooling

The thermostat for oil cooling is also integrated into the oil sump. It only lets the oil flow over the oil cooler as of a certain oil temperature, thus ensuring rapid heating of the engine oil. The oil coolers used are two engine oil to air heat exchangers. These are positioned behind the trim panel of the front bumper in the wheel arches.

Oil Spray Nozzles

Oil spray nozzles are always used when an oil duct cannot be routed directly to the lubrication and cooling point. In the N74 engine, these are the usual positions, namely the oil spray nozzles for piston crown cooling and the oil spray nozzles for timing chain lubrication.

■ Oil spray nozzles for piston crown cooling

In the same way as in the N63 engine, the pistons are cooled by an oil spray from the underside. Six double oil spray nozzles are used. They only open (pressure-controlled) above 1.5 bar, thus enabling an adequately high volumetric flow of oil to maintain the VANOS adjustment in hot-idling mode.

■ Oil spray nozzles for timing chain lubrication

The oil spray nozzles for timing chain lubrication are integrated in the chain tensioners of the two cylinder banks. They spray the engine oil directly onto the timing chains. A restrictor in the oil spray nozzle limits the oil quantity delivered.

Oil Level Measurement

The familiar QLT (Quality Level Temperature) oil condition sensor is used in the N74 engine. This implements the electronic oil level measurement. No oil dipstick is used.

Engine Cooling

Because of the turbocharging and indirect charge air cooling, the N74 engine has the same cooling requirements as the N63 engine. Consequently it too has two separate cooling circuits. One is for cooling the engine and exhaust turbochargers, the other is for charge air cooling and for cooling the two engine control units.

The engine cooling system performs the task of drawing heat off the engine and maintaining the operating temperature as constant as possible. As on the N54 and N63 engines, the two exhaust turbochargers are also cooled.

On the N74 engine, the coolant passages have been integrated mainly in the engine block. Optimizations to the engine cooling circuit have enabled a significant reduction in the coolant quantity for the bypass mode, thus shortening the warm-up phase.

The coolant feed line downstream of the coolant pump is routed directly beside the engine's main oil duct. The oil in the main oil duct flows in the opposite direction to the coolant. This enhances the heat exchange between the two media, and has a positive effect on the engine oil temperature. The overall cooling effect is comparable with that of an engine oil-coolant heat exchanger.

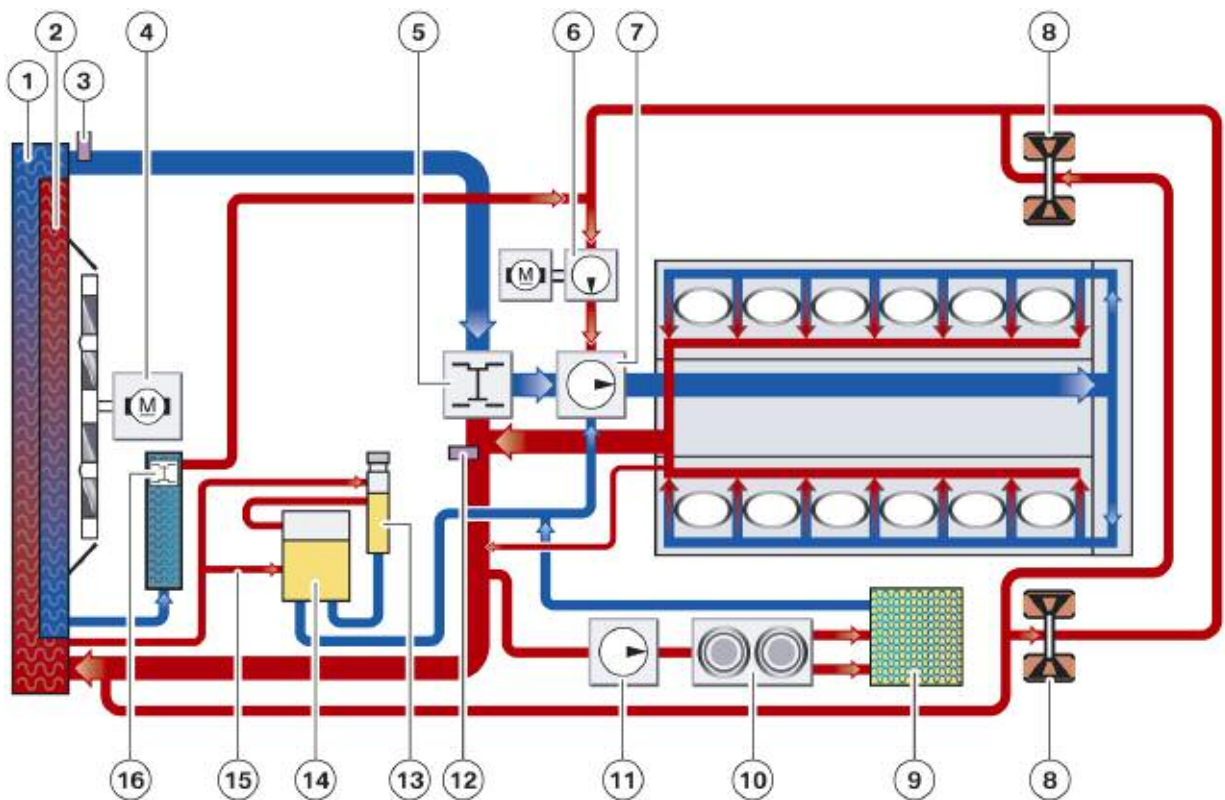

Engine cooling circuit of the N74 engine

Index	Explanation
1	Radiator
2	Radiator for transmission cooling
3	Coolant temperature sensor at radiator outlet
4	Electric cooling fan
5	Characteristic map thermostat
6	Electric auxiliary coolant pump for turbocharger cooling
7	Coolant pump (mechanical)
8	Exhaust turbocharger
9	Heater core
10	Duo Heater valve
11	Electric auxiliary coolant pump for vehicle heating
12	Coolant temperature sensor at engine outlet
13	Filling canister
14	Expansion tank
15	Vent line
16	Transmission fluid thermostat and the fluid-to-coolant heat exchanger

The coolant passages in the cylinder heads are similar to the N63 engine. The coolant flows through the cylinder heads diagonally from the outside to the inside, whereby it flows in at the rear (outside) and flows out at the front (inside). This is also known as diagonal cooling.

As on the N63 engine, an additional electric coolant pump is used which supplies the bearings of the exhaust turbochargers with coolant.

Coolant Pumps

■ Main coolant pump

The main coolant pump is a conventional coolant pump driven mechanically by the belt drive.

■ Auxiliary water pump for exhaust turbochargers

Like the N63 engine, the N74 engine has an electric auxiliary water pump which allows heat to be dissipated from the exhaust turbochargers even after the engine has been switched off. This coolant pump has an electrical power output of 20 W. It is also used during engine operation to support exhaust turbocharger cooling. The electric auxiliary coolant pump is activated based on the following factors:

- Coolant temperature at the engine outlet
- Engine oil temperature
- Injected volume of fuel

The injected volume of fuel is used to calculate the heat contribution to the engine. Operation is similar to that of the heat management system on the 6-cylinder engines. The after-running period of the electrical auxiliary coolant pump can last up to 30 minutes.

To improve the cooling effect, the electric fan is also switched on. As in previous systems, the electric fan runs for a maximum of 11 minutes, however, it now operates more frequently.

Expansion Tank

For space reasons, the expansion tank is located in the front fender behind the wheel arch. A separate filling canister bolted to the front of the engine enables filling. The expansion tank and filling canister are interconnected by an expansion and tank ventilation line.

Charge Air Cooling

The N63 engine was the first BMW engine to use indirect charge air cooling; this has now also been adopted for the N74 engine. The heat is extracted from the charge air by means of an air to coolant heat exchanger. This heat is then released to the ambient air across a coolant to air heat exchanger. To achieve this, the charge air cooling has its own low-temperature cooling circuit. This is independent of the engine cooling circuit.

N74 Cooling Circuit for Charge Air Cooling

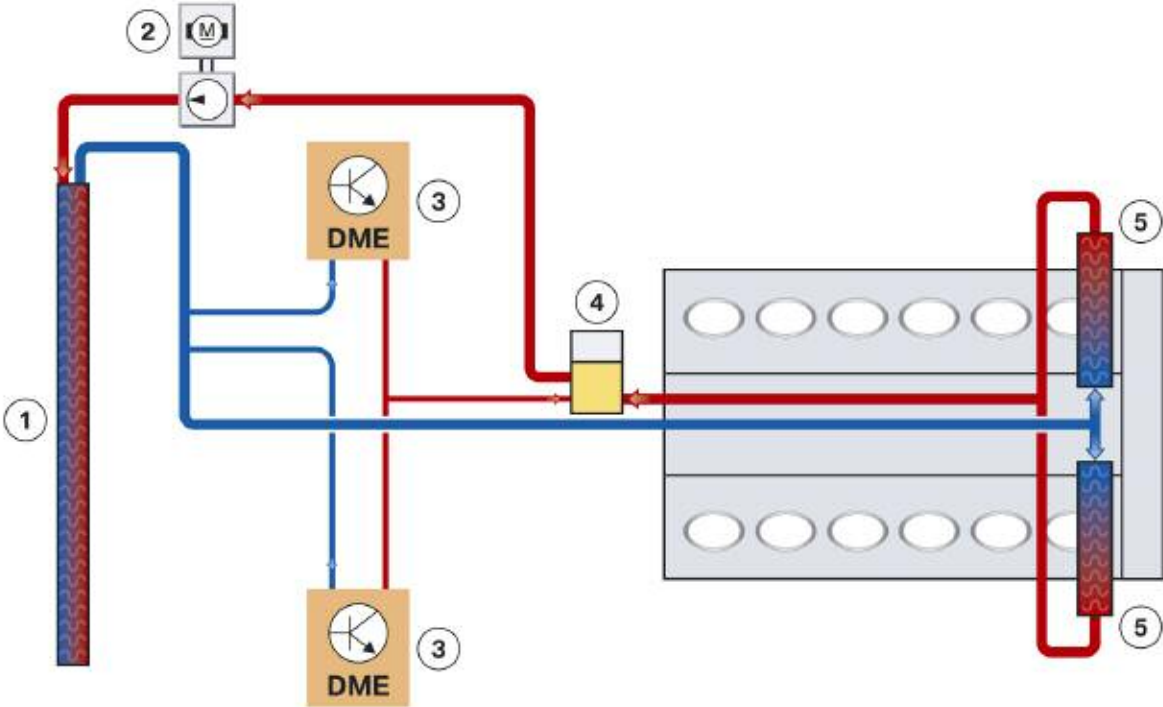

Index	Explanation
1	Radiator for charge air cooling
2	Electric coolant pump for charge air cooling
3	Engine control unit
4	Expansion tank
5	Charge-air cooler

N74 Air Intake and Exhaust System

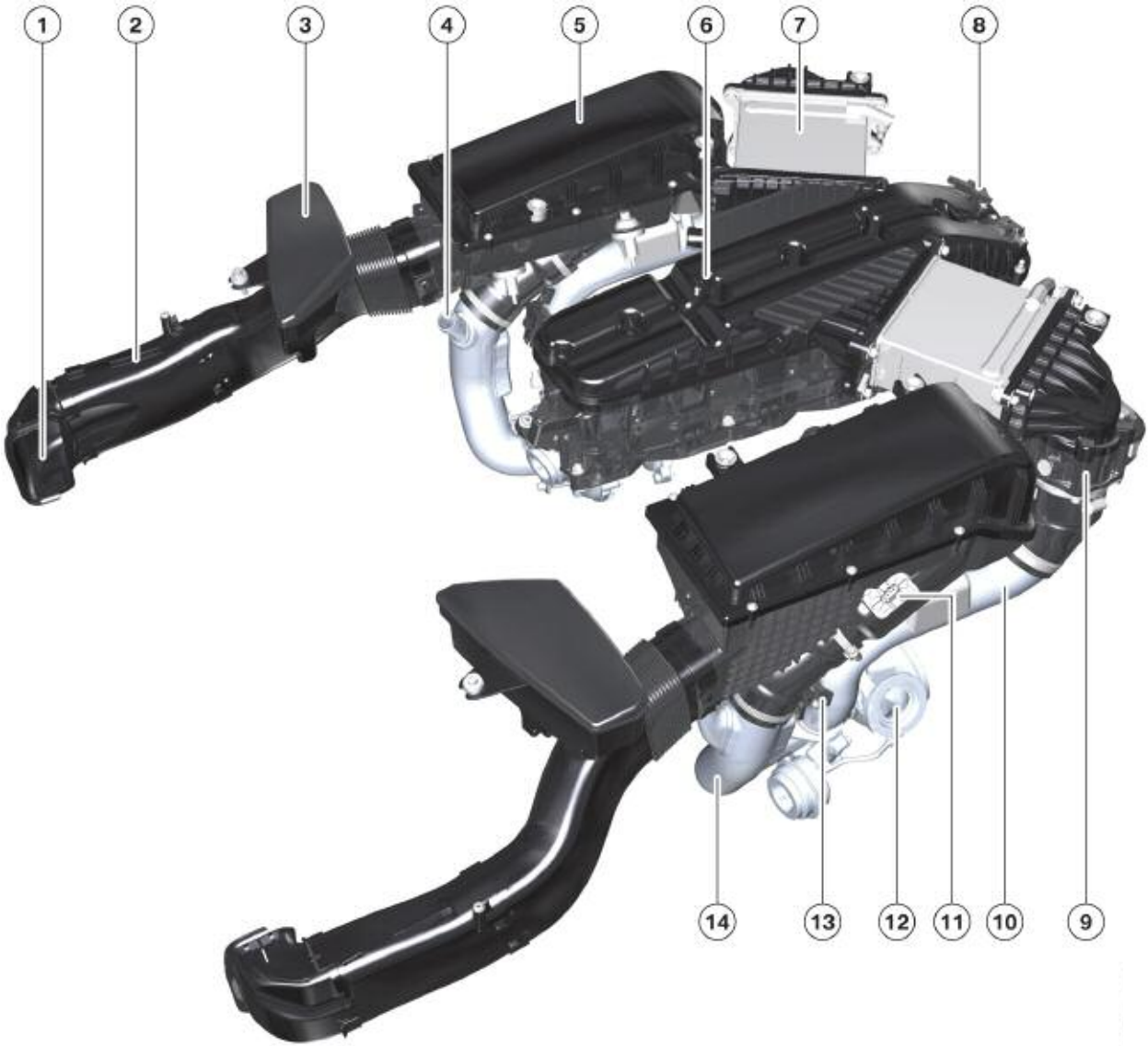

Index	Explanation
1	Unfiltered air intake
2	Unfiltered air pipe
3	Unfiltered air resonator
4	Connection for crankcase ventilation, charged operation
5	Intake silencer
6	Intake manifold
7	Charge-air cooler
8	Charging pressure sensor
9	Throttle valve
10	Charge air pipe
11	Hot film air mass meter
12	Exhaust-gas turbocharger
13	Charge-air temperature sensor
14	Purified air pipe

Auxiliary Coolant Pump for Charge Air Cooling

The cooling circuit for charge air cooling is operated with a 50 W pump. It does not run automatically when the engine is switched on.

The following parameters are used for the auxiliary pump activation:

- Outside temperature
- Difference between charge-air temperature and outside temperature.

Charge-air Cooler

The charge air coolers (intercoolers) are attached to the intake system near the rear of the cylinder heads. They enable efficient cooling of the charge air by extracting heat energy from the air charge and carrying it away to the coolant to air heat exchanger located in the front of the vehicle.

Engine Control Unit

The low temperature cooling circuit for charge air cooling also cools the two engine control units. A cooling line from the low-temperature cooling circuit is connected to the housing of the control units.

Intake Air Duct

The air intake duct consists of two lines with engine-mounted intake silencers. The arrangement leads to minimum pressure losses on the intake and pressure sides. The air is drawn in on both sides of the engine through a duct behind the front grille. An air intake resonator on each side enhances the acoustic characteristics of the system.

Hot film air mass meters (digital HFM 7) with integrated electric throttle valves are used. They are located in the outlet pipe of each turbocharger, bolted to the inlet of the inter-cooler.

View of the N74 left Turbocharger pressure pipe and HFM



Turbocharging

Exhaust Turbocharger

As already mentioned, the turbochargers on the N74 engine are located on the outside. In the case of a V12-cylinder engine with 60° cylinder angle, this is the optimal arrangement of the turbocharger system.

These are conventional single scroll turbochargers (no variable turbine geometry, VNT, or twin scroll are used) in which vacuum-controlled wastegate valves are used for charging pressure control.

N74 Exhaust Turbochargers

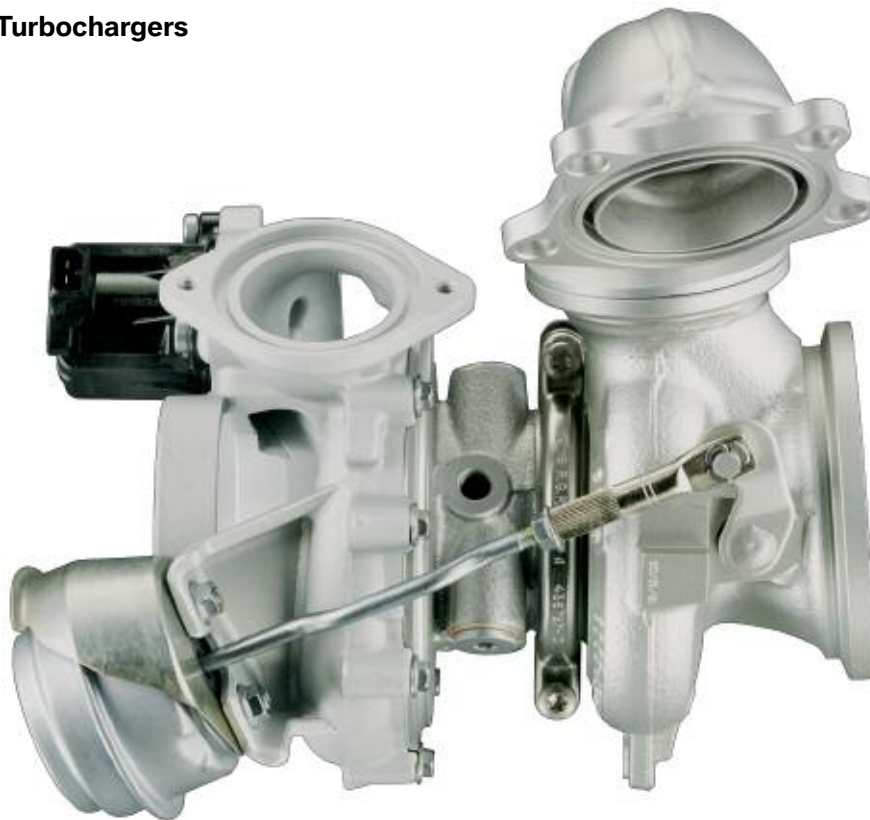

The turbocharging process on the N74 engine is identical, in terms of its principle to that utilised on the N63 engine. Each bank of cylinders has its own (relatively small) turbocharger, which ensures fast response even at low engine speeds. The charging pressure control is via wastegate valves. Blowoff valves are also used.

N74 Turbocharger Details

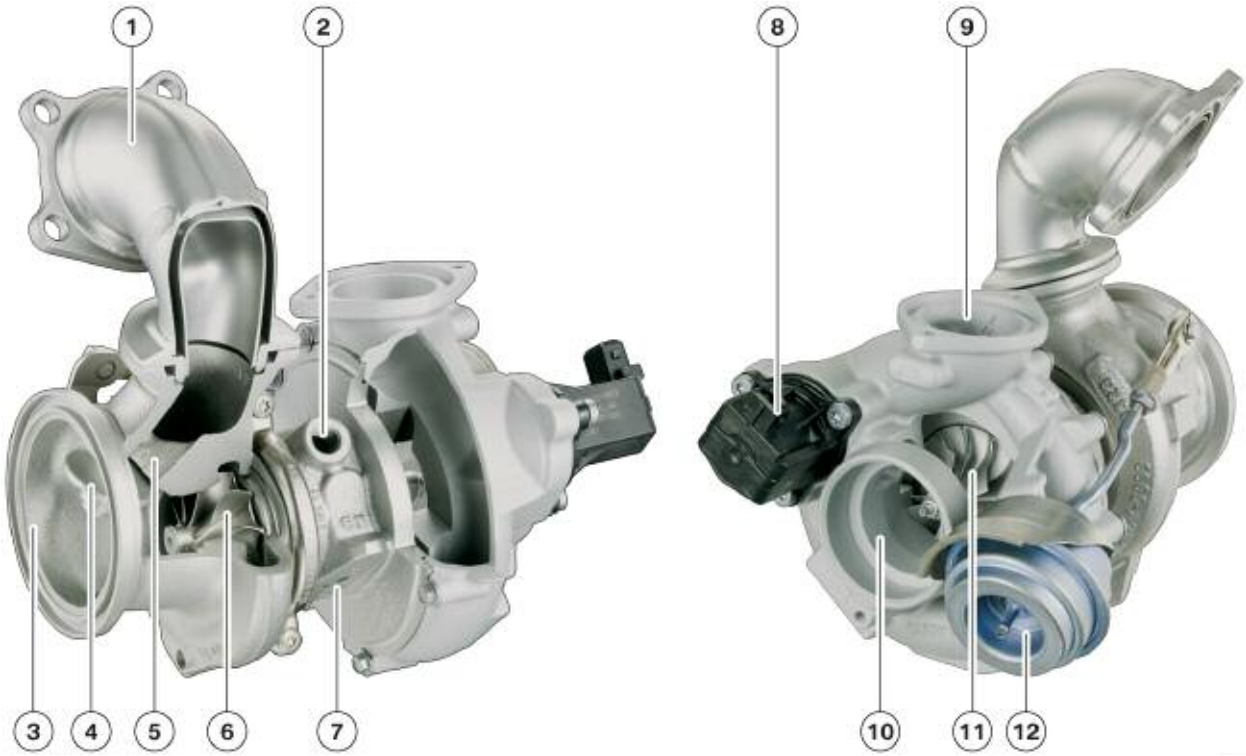

Index	Explanation
1	Connection from exhaust manifold (turbine inlet)
2	Connection for coolant line
3	Connection to catalytic converter (turbine outlet)
4	Wastegate valve
5	Wastegate duct
6	Turbine wheel
7	Connection for overflow duct
8	Diverter (blow-off) valve
9	Connection to charge air cooler (compressor outlet)
10	Connection from intake silencer (compressor inlet)
11	Impeller
12	Vacuum unit for wastegate valve activation

Charging Pressure Control

The charging pressure (Boost) of the turbochargers is directly dependent on the exhaust flow that enters the turbines and it determines the speed of the turbocharger. Both the speed and the mass of the exhaust flow are directly dependent on the engine speed as well as the engine load. The Digital Motor Electronics controls the charging pressure through the wastegate valves. The wastegate valves are operated by vacuum units and are controlled by the DME through vacuum solenoids (EPDW).

The vacuum is generated using the permanently driven vacuum pump of the engine and stored in two vacuum reservoirs. It is ensured that these consumers do not have a negative influence on the function of the power brake booster by using a two stage vacuum pump.

The wastegate valves can influence how much of the exhaust flows through the turbine wheel. Once the charging pressure has reached the desired level, the flap of the wastegate valve starts to open and a portion of the exhaust flow is routed past the turbine wheel. The decreased exhaust flow through the turbine prevents the speed of the compressor from increasing further.

In full load operation, the N74 engine works with an excess boost pressure of up to 0.7 bar in the intake manifold.

■ Blow-off control

Like the N63 engine, the N74 has electric diverter (blow-off) valves incorporated directly into the turbochargers.

The blow-off valves reduce unwanted peaks in the charge air pressure that can arise when the throttle valve is closed quickly. In doing so, they perform an important function with regard to engine acoustics and contribute to protecting the components of the turbochargers.



Diverter (Blow-off) Valve

If the throttle valve is closed, the charging pressure (before the throttle valve) and its rise are compared with stored nominal values. If the actual values are a certain value above the nominal values, the blowoff valves are opened. This diverts the boost pressure to the intake side of the compressor and eliminates the unwanted pressure that can damage system components.

Charge Air Cooling

Like the N63, the N74 engine also has indirect charge air cooling. The heat from the pressurized fresh air is transferred to the coolant flowing inside two (air to coolant) inter-coolers. Then it flows to a dedicated heat exchanger where the heat energy is then released into the ambient air. This system enables the charge air pipe length to be kept very short, thereby reducing pressure losses.

The charge air coolers are mounted on top of the engine, directly connected to the air intake system.



Intake Manifold

The air intake system is plastic and located in the V chamber of the engine. The left and right sides are separate. This is why there are also two charging pressure sensors at the rear end of the air intake system.

Exhaust System

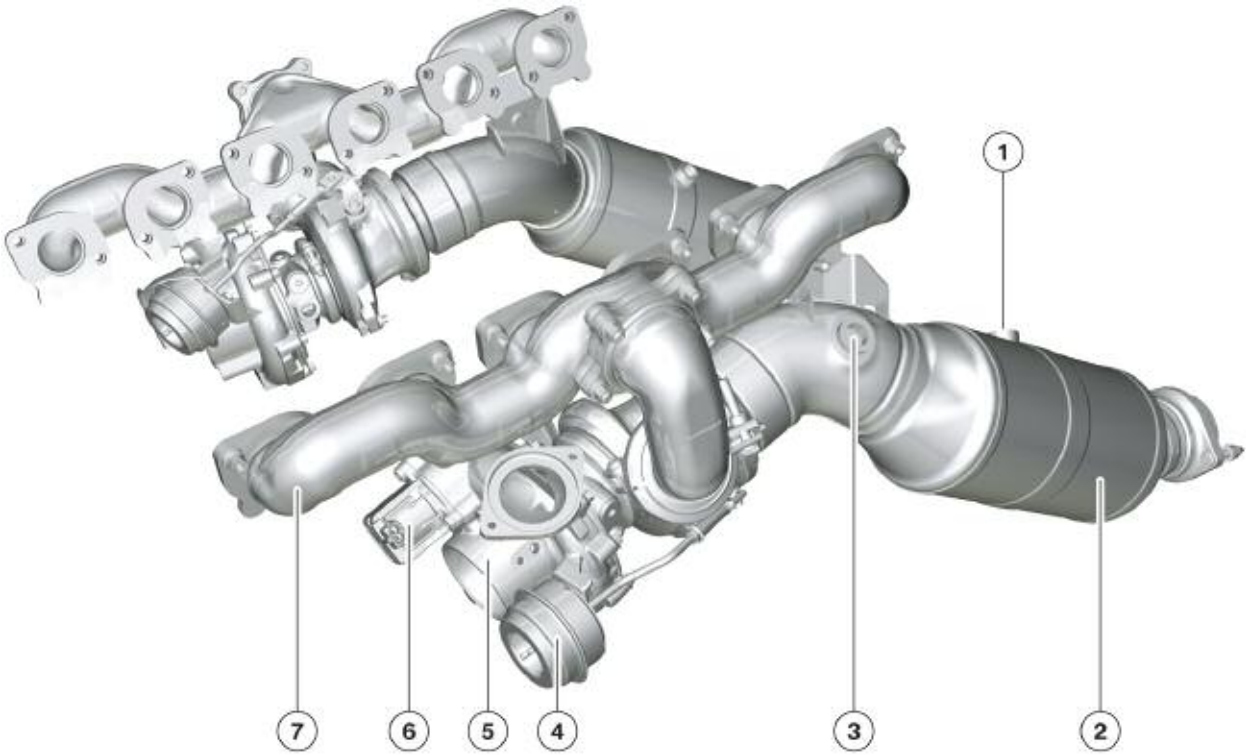

Index	Explanation
1	Position of exhaust gas oxygen sensor (monitoring sensor) after catalytic converter
2	Catalytic converter
3	Position of exhaust gas oxygen sensor (control sensor) before catalytic converter
4	Vacuum unit for wastegate valve activation
5	Exhaust turbocharger
6	Diverter (blow-off) valve
7	Exhaust manifold

Exhaust Manifold

Air-gap-insulated exhaust manifolds are used, they promote faster heating of the catalytic converters. They have a 6 into 2 into 1 design which optimizes the gas flow based on the ignition firing sequence.



Exhaust Emissions

The catalytic converters are installed very close to the engine, directly behind the turbocharger turbines. This ensures the catalytic converters reach their operating temperature quickly. The use of the latest exhaust gas sensors, the LSU ADV exhaust gas oxygen sensor and a secondary air system means that the engine complies with the strict ULEV 2 exhaust emission standards.

Secondary Air System

As on N73 engine, the N74 is equipped with a secondary air system. Blowing additional air (secondary air) into the exhaust gas duct in the cylinder head during the warm-up phase initiates thermal post-combustion that leads to a reduction in the unburned hydrocarbons (HC) and carbon monoxide (CO) contained in the exhaust gas. The energy generated here heats up the catalytic converter faster in the warm-up phase and increases its conversion rate. The catalytic converter response temperature (light-off temperature) of 300°C is reached only a few seconds after the engine is started.

What is new is that there is one pressure sensor before each secondary air valve. The function of the secondary air system is monitored by registering the pressure conditions.

■ Secondary air pump

The electrically operated secondary air pump is attached to the cylinder head of cylinder bank 1.

During the warm-up phase, the pump draws in fresh air from the engine compartment. This is cleaned by the filter integrated in the pump and delivered across the pressure line to the two secondary air valves.

After the engine start, the secondary air pump is supplied with vehicle voltage by the DME via the secondary air pump relay. The switched-on period is about 20 seconds and it depends essentially on the coolant temperature at engine start. It is activated from a coolant temperature of +5°C to +50°C (40°F to 120°F).



■ Secondary air valve

A secondary air valve is bolted onto the rear of each cylinder head. The secondary air valve opens as soon as the system pressure generated by the secondary air pump exceeds the opening pressure of the valve. Secondary air is fed via the secondary air line into the elongated passage of the cylinder head. From the elongated passage, 24 tap holes lead to the 12 exhaust ducts where the thermal post-combustion takes place.

The secondary air valve closes as soon as the secondary air pump switches off, thus preventing exhaust gas from flowing back to the secondary air pump.



**Secondary Air Valve
and Pressure Sensor**

■ On-board diagnosis of secondary air system

Monitoring takes place with the help of the pressure sensors that are fitted before each of the secondary air valves. The exhaust gas oxygen sensors are also used.

The overall diagnosis is divided into a rough diagnosis that begins immediately after the secondary air pump starts up and the fine diagnosis that begins around 12 to 14 seconds after the secondary air injection starts.

The rough diagnosis uses only the pressure signals. Every fault in the secondary air system is detected if there is a drop below a minimum pressure in the event of a leakage or if a maximum pressure is exceeded when a valve is clogged or jammed closed. However, under certain circumstances, it might not be possible to assign the fault correctly, because the pressure sensors indicate the same pressure due to the connecting line.

The fine diagnosis uses the exhaust gas oxygen sensor signals in addition to the pressure signals. The combination of exceeding or falling short of fault thresholds for the pressure and exhaust gas oxygen sensor values means the fault can be precisely assigned to the relevant cylinder bank. The fine diagnosis relies on the oxygen sensor readiness, this is available much later than in naturally aspirated engines due to the heat loss through the turbocharger.

There is also an electrical diagnosis for the secondary air pump relay and for the pressure sensors. These indicate the usual electrical faults (line disconnection, short circuit to ground, short circuit to supply voltage). There is an additional mutual plausibility check of the pressure sensors on initialization with ambient pressure.

Vacuum System

The vacuum system is similar to that of the N63 engine. A two-stage vacuum pump is used, the main stage of which generates the vacuum for the brake servo. The auxiliary stage generates the vacuum to activate the wastegate valves of the exhaust turbochargers and the exhaust flaps.

N74 Vacuum System

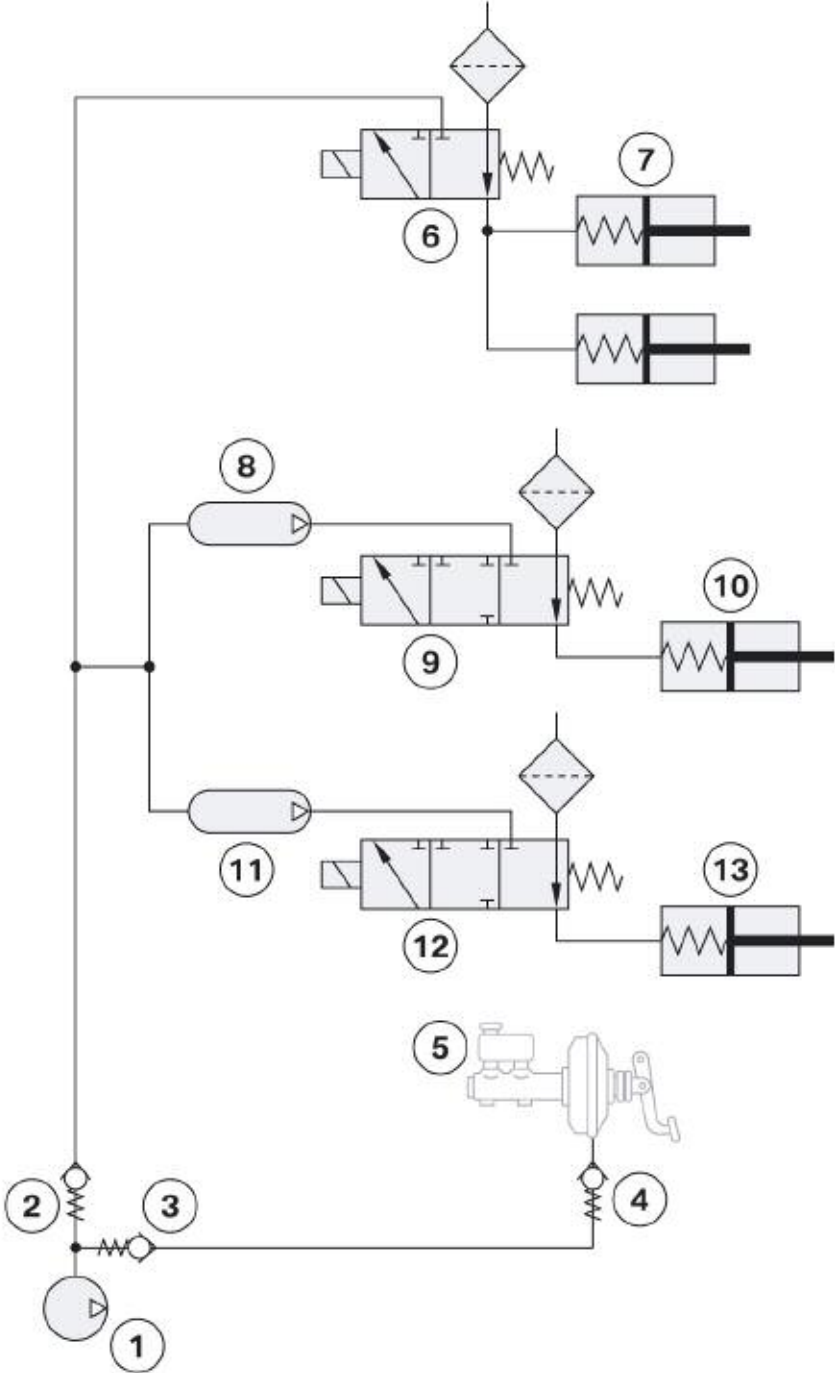

Index	Explanation
1	Vacuum pump
2	Non-return valve for auxiliary vacuum units
3	Non-return valve for brake servo
4	Non-return valve on brake servo
5	Brake servo
6	Electric changeover valve
7	Vacuum unit for exhaust flaps
8	Vacuum accumulator
9	Vacuum solenoid (EPDW)
10	Vacuum unit for wastegate valve, cylinder bank 1
11	Vacuum accumulator
12	Vacuum solenoid (EPDW)
13	Vacuum unit for wastegate valve, cylinder bank 2

In contrast to the N63 engine, the N74 engine has two vacuum reservoirs for the wastegate valves. These are attached to the rear end of the intake system. Vacuum solenoids (EPDW) for the wastegate valves are mounted directly on the vacuum reservoirs (see arrows).

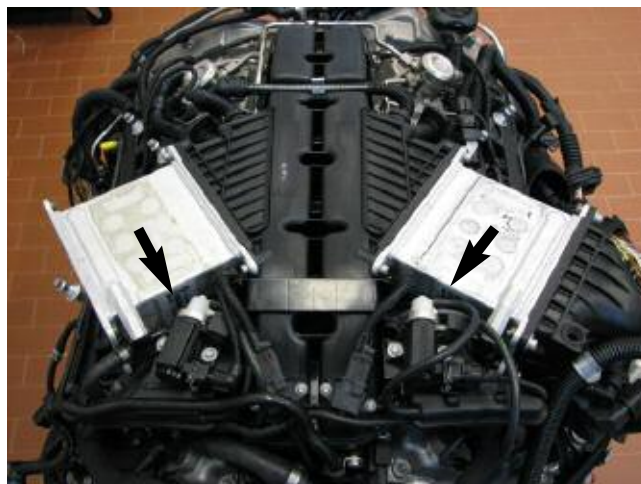

Fuel Injection

The N74 engine is equipped with high precision injection. This second generation direct fuel injection operates in homogeneous operation at all times and has the same structure as on the N63 engine.

N74 Fuel Injection System

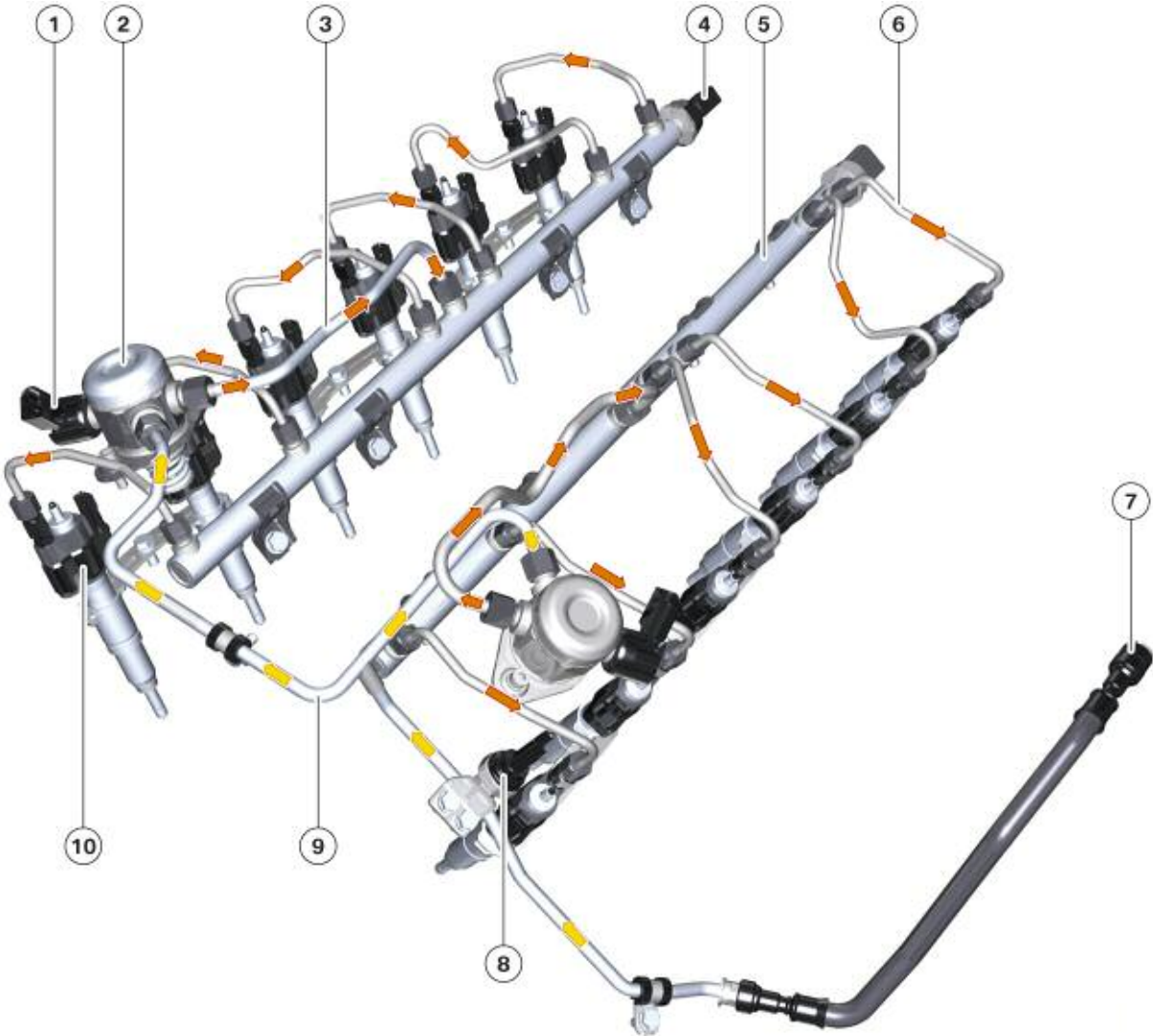

Index	Explanation
1	Quantity control valve
2	High pressure pump
3	High pressure line (pump - rail)
4	Rail pressure sensor
5	Rail
6	High pressure line (rail - injector)
7	Fuel feed from the electric fuel pump
8	Fuel pressure sensor
9	Feed line
10	Piezo injector

The fuel is delivered to the high pressure pump from the fuel tank by the electric fuel pump via the feed line at a delivery pressure of 5 bar. The delivery pressure is monitored by the fuel pressure sensor. The fuel is supplied by the electric fuel pump depending on engine requirements. If this sensor fails, the operation of the electric fuel pump continues with a 100% delivery rate at terminal 15 ON. The fuel is compressed in the permanently driven single-piston high pressure pump and fed via the high pressure line into the fuel rail. The pressurized fuel in the rail is distributed via the high pressure lines to the piezo injectors.

The required fuel pressure is determined by the DME depending on engine speed and load. The pressure reading is picked up by the rail pressure sensor and sent to the DME. Control takes place on the basis of a nominal/actual comparison of the rail pressure by the quantity control valve. With 200 bar of fuel pressure only required at high load and lower engine speed. The purpose of the system is to achieve the smoothest operation with the lowest possible fuel consumption.

High Pressure Pump

The high pressure pump is, in principle, the same as the one used on the N63 engine. The only difference is that the fuel lines are positioned at a different angle.

N74 High Pressure Pump with Quantity Control Valve

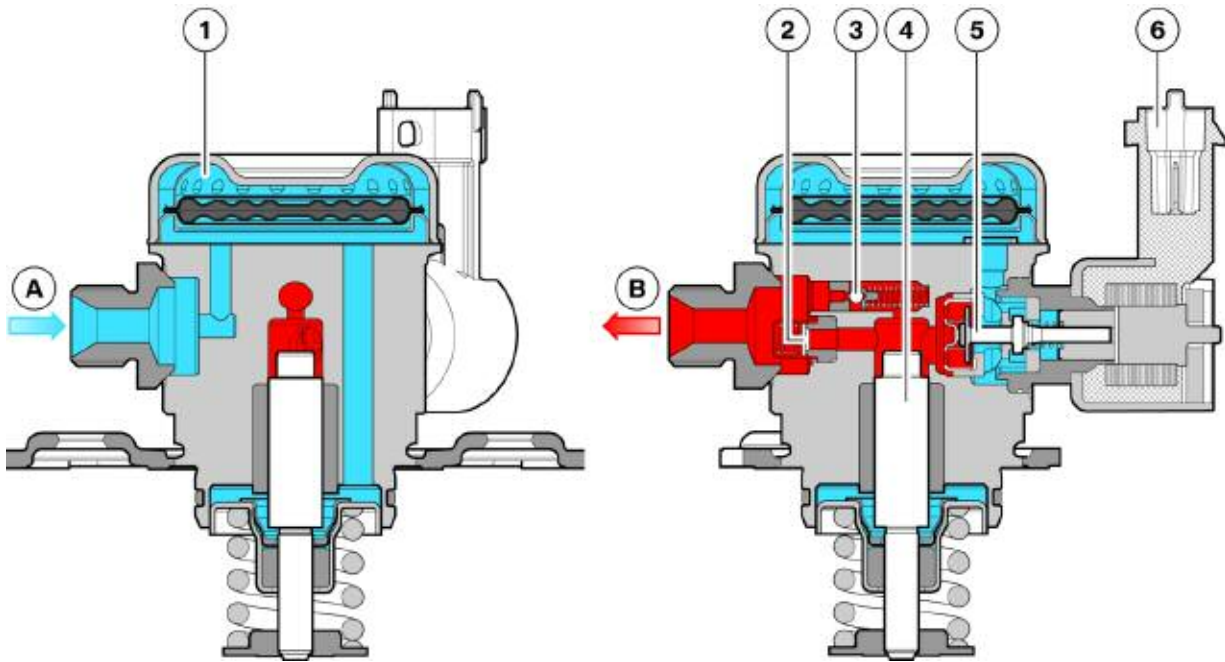

Index	Explanation
A	Low-pressure connection
B	High-pressure connection
1	Compensating chamber
2	High-pressure non-return valve
3	Pressure limiting valve
4	Pistons
5	Quantity control valve
6	Electrical connection of the quantity control valve

The fuel is delivered to the high-pressure pump via the inlet with delivery pressure generated by the electric fuel pump. The fuel is then fed via the volume control valve and into the compression chamber of the pump element. In this pump element, the fuel is placed pressurized by a plunger and supplied via the high-pressure non-return valve to the high-pressure connection. The high-pressure pump is bolted onto the cylinder head and is driven by the camshaft by a triple cam. This means that, as soon as the engine is running, the triple cam continuously moves the plunger. Fuel is pressurized until new fuel is delivered via the volume control valve into the high-pressure pump. The volume control valve is activated by the engine management system; it specifies the delivered volume of fuel. Pressure regulation takes place via the volume control valve in that it is opened or closed by the pump element towards the fuel feed. When the quantity control valve is opened, most of the fuel drawn in by the piston is pressed back into the fuel feed.

The maximum pressure in the high-pressure area is restricted to 245 bar. If the maximum high pressure is reached, the high-pressure circuit is relaxed to the low-pressure area by a pressure limiting valve. In this case the pressure peak in the low pressure area is compensated for by the fluid volume in the area and pressure damper in the compensating chamber. The compensating chamber is integrated into the inlet towards the high pressure pump. This ensures that pressure peaks are lowered by connecting and disconnecting the high and low-pressure areas. When the piston generates pressure, fuel flows between the piston and its guide. This is deliberate, as it lubricates the pair of sliding elements. On downward movement of the pressure piston, a high pressure would arise at its rear side. This would lead to danger if the fuel is pressed through the sealing of the piston from the pump into the oil circuit of the engine. The connection to the compensating chamber means that there is never a higher pressure behind the piston than in the fuel feed. This prevents pressure fluctuations from being transferred into the low pressure fuel system, as the volume changes in front of and behind the piston are balanced.

Hydraulic Circuit Diagram

N74 Fuel System, Hydraulic Circuit Diagram

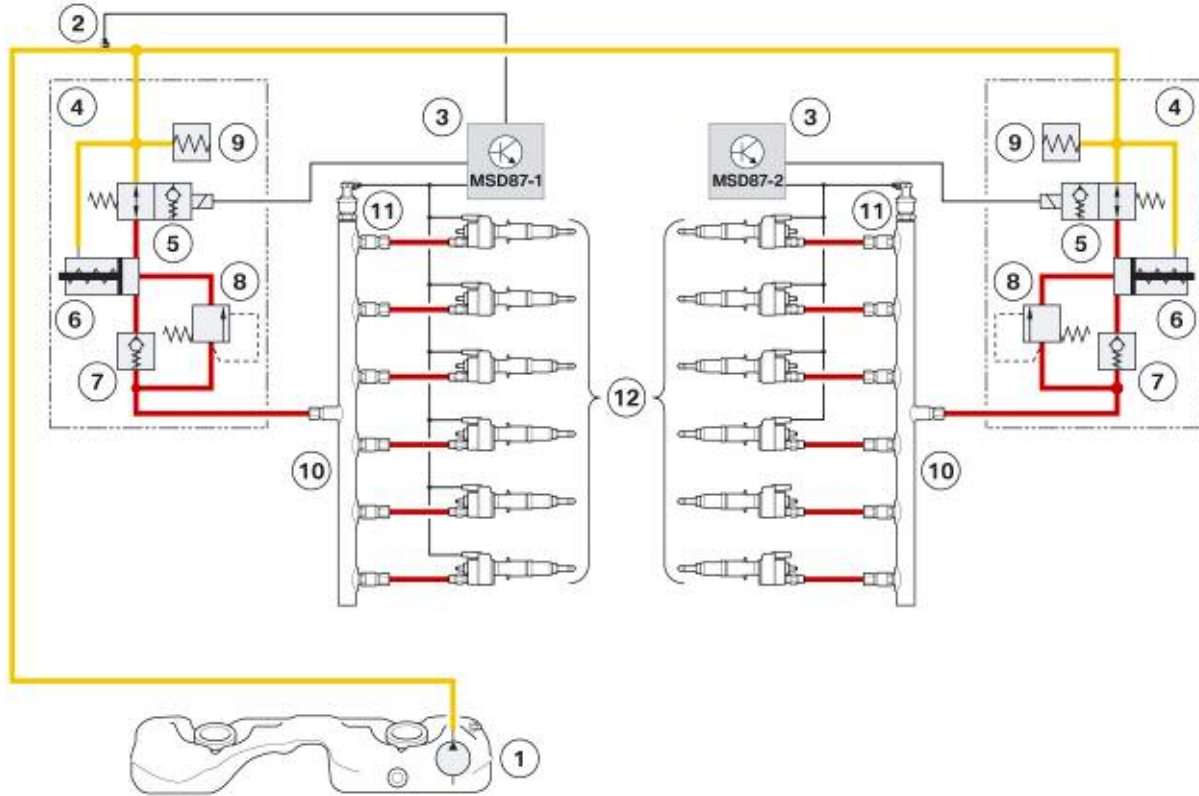

Index	Explanation
1	Electric fuel pump
2	Fuel pressure sensor
3	Engine control unit
4	High pressure pump
5	Quantity control valve
6	High pressure pump element (piston)
7	High pressure non-return valve
8	Pressure limiting valve
9	Compensating chamber
10	Rail
11	Rail pressure sensor
12	Piezo injectors

The volume control valve controls the fuel delivery pressure in the rail. In the induction stroke with the quantity control valve opened, the entire compression chamber is filled with fuel via the low-pressure area. In the compression stroke, the point in time when the quantity control valve closes determines how much fuel is pumped back into the low-pressure area and how much of the remaining stroke is used for the compression and the effective high pressure delivery. In addition, the pressure limiting valve provides the possibility to reduce the pressure in the rail in that fuel is fed out of the high-pressure fuel system back into the pump element.

Injectors

The outward opening, piezo injectors are an integral part of the “spray-guided” injection strategy used on the HPI injection system. These are already familiar from the N54 and N63 engines.

Outward-opening Piezo Injector

The piezo injector is integrated into the cylinder head together with the spark plug in the center of the combustion chamber between the intake and exhaust valves. This installation position prevents the cylinder walls or piston crown from being soaked with injected fuel. An even formation of the homogeneous fuel-air mixture is achieved with the help of the gas turbulence in the combustion chamber and a stable fuel cone. The gas motion is influenced by the geometry of the inlet ports on the one hand and by the shape of the piston crown on the other. The injected fuel is swirled in the combustion chamber with the charge air until a homogeneous fuel-air mixture is available everywhere in the compression chamber at the ignition point.

Control Unit

Two water-cooled MSD87-12 control units are used. The same water tight components as those on the MSD85 (N63 engine in the F01) have been used. As on the predecessor engine N73, a primary (master) and secondary concept strategy has been implemented with the two control units. They have the same hardware, software and data records. The connected sensor system runs an automatic primary (master) and secondary identification. In this arrangement, the master is responsible for communication with the complete vehicle and the specified nominal values for the engine functions. The control unit is designed with the current software for the vehicle network with FlexRay.