

Reference Manual



F48 LCI COMPLETE VEHICLE



Technical Training

The information contained in this manual is not to be resold, bartered, copied or transferred without the express written consent of BMW of North America, LLC ("BMW NA").

Copyright © 2019 BMW of North America, LLC

Technical training.
Product information.

F48 LCI Complete Vehicle



BMW Service

Edited for the U.S. market by:

BMW Group University
Technical Training

ST1909

9/1/2019

General information

Symbols used

The following symbol is used in this document to facilitate better comprehension or to draw attention to very important information:



Contains important safety information and information that needs to be observed strictly in order to guarantee the smooth operation of the system.

Information status: May 2019

BMW Group vehicles meet the requirements of the highest safety and quality standards. Changes in requirements for environmental protection, customer benefits and design render necessary continuous development of systems and components. Consequently, there may be discrepancies between the contents of this document and the vehicles available in the training course.

The information contained in the training course materials is solely intended for participants in this training course conducted by BMW Group Technical Training Centers, or BMW Group Contract Training Facilities.

This training manual or any attached publication is not intended to be a complete and all inclusive source for repair and maintenance data. It is only part of a training information system designed to assure that uniform procedures and information are presented to all participants.

For changes/additions to the technical data, repair procedures, please refer to the current information issued by BMW of North America, LLC, Technical Service Department.

This information is available by accessing TIS at www.dealerspeed.net.

Additional sources of information

Further information on the individual topics can be found in the following:

- Owner's Handbook
- Integrated Service Technical Application
- Aftersales Information Research (AIR)

The information contained in this manual is not to be resold, bartered, copied, or transferred without the express written consent of BMW of North America, LLC (“BMW NA”).

©2019 BMW of North America, LLC

The BMW name and logo are registered trademarks. All rights reserved.

F48 LCI Complete Vehicle

Contents

1.	Introduction	1
1.1.	Further information.....	1
1.2.	Models.....	1
2.	Body	2
2.1.	Exterior equipment.....	2
2.1.1.	Front.....	2
2.1.2.	Rear.....	3
2.1.3.	M Sport package.....	3
2.1.4.	Window washer system.....	4
2.2.	Interior equipment.....	4
2.2.1.	Light package.....	4
2.2.2.	Rear seats.....	7
3.	Drivetrain	8
3.1.	Gasoline engine.....	8
3.1.1.	Coolant bleeding routine of B46TU engine.....	8
3.2.	Antifreeze and corrosion inhibitor.....	8
3.3.	Automatic engine start/stop function.....	9
3.3.1.	Advantages.....	10
3.3.2.	Notes for Service.....	10
3.4.	Transmission.....	11
3.4.1.	Gear selector lever.....	11
3.4.2.	ConnectedShift.....	13
4.	General Vehicle Electronics	15
4.1.	Bus overview.....	15
4.2.	Alternator.....	17
4.3.	Battery.....	17
4.3.1.	Enhanced Flooded Battery.....	17
4.4.	Exterior lights.....	18
4.4.1.	Headlight.....	18
4.4.2.	Rear lights.....	19
4.5.	Assistance systems.....	20
4.5.1.	Driving Assistant.....	20
4.6.	Infotainment.....	20
4.6.1.	Wireless charging.....	21
4.6.2.	USB interfaces.....	24
4.6.3.	Head unit.....	26
4.6.4.	Controller.....	26
4.6.5.	User interface.....	26

F48 LCI Complete Vehicle

Contents

4.7.	ID transmitter.....	27
------	---------------------	----

F48 LCI Complete Vehicle

1. Introduction

1.1. Further information

In July the BMW X1 receives a life cycle impulse (LCI).

This includes visual and functional new features and changes, as well as modifications in the general vehicle electrical system.

Many of these modifications have been adopted from vehicle models that have already been described. The topics listed below are described in the product information material for further information.

Topic	Product information
Gasoline engine	ST1837 "B46TU / B48TU Engines"
Wireless charging	ST1702 "F39 Complete Vehicle"
User interface	ST1604 "G30 Displays and Controls"
Automatic Transmission	ST1845 "F39 X2 M35i Transmission"



External view of the F48 LCI

1.2. Models

The following table provides an overview of the available model ranges:

Model	Engine	Emission rating	Automatic transmission
xDrive28i	B46A2001	SULEV	- - GA8Y45EW
sDrive28i	B46A2001	SULEV	- - GA8Q45EW

F48 LCI Complete Vehicle

2. Body

2.1. Exterior equipment

2.1.1. Front

The appearance of the front and rear sections of the F48 LCI was overhauled. The larger radiator grill in the characteristic sporty design ensures a more confident appearance.



Front view

Change

- Larger design of the radiator grill
- Design of the air inlets of bumper
- Design of the headlights
- LED fog lights

F48 LCI Complete Vehicle

2. Body

2.1.2. Rear



TG19-0289

Rear view

Change

- LED tail lights
- Larger tailpipe trim

2.1.3. M Sport package

The M Sport package was also redesigned. Sharper contours and larger air inlets now highlight the sporty character even more.



TG19-0882

M Sport package

F48 LCI Complete Vehicle

2. Body

2.1.4. Window washer system

The window washer jets of the windscreen wiper system was extended with a third injector nozzle in the center. As a result, the cleaning performance is improved, thereby ensuring enhanced safety when driving.



Washer jets

2.2. Interior equipment

2.2.1. Light package

The optional equipment "Ambient Lighting" (SA 563) has been extended. The customer now has a choice of 6 predefined light designs for the ambient lighting in the decorative strip of the instrument panel, the storage compartment center stack and the door mirror lighting at the front and rear. The ambient lighting is achieved by using red, green and blue LEDs.

F48 LCI Complete Vehicle

2. Body



Ambient lighting

Another element of the light package is the two-tone X1 projection on the driver's side. The projection is visible when the welcome light is active from the side mirror onto the ground below the driver's door.



Exterior mirror projection light package

F48 LCI Complete Vehicle

2. Body

System wiring diagram

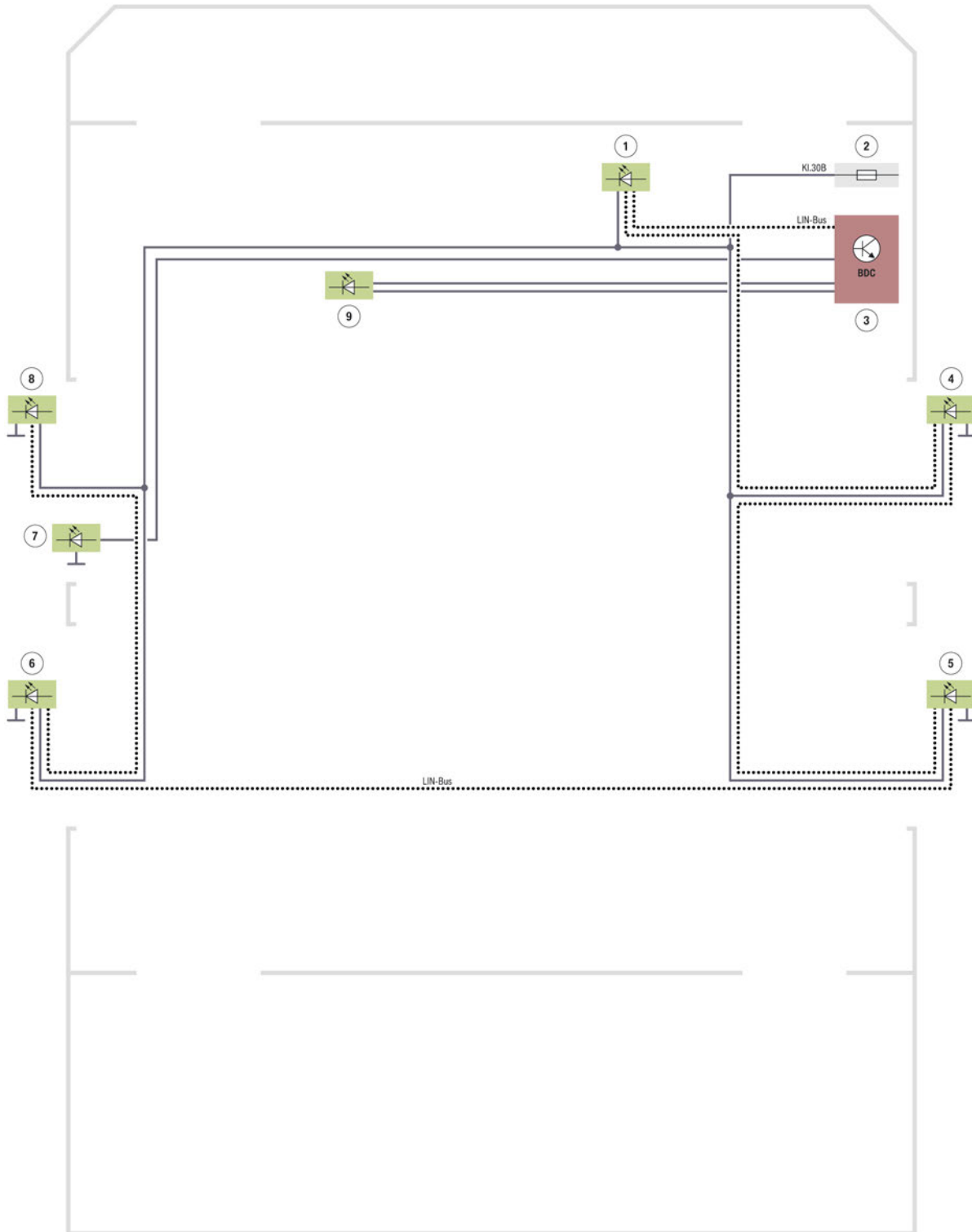

Ambient lighting and projection

TE19-0292

F48 LCI Complete Vehicle

2. Body

Index	Explanation
1	Lighting, decorative strip, cockpit, front passenger
2	Front power distribution box, front passenger
3	Body Domain Controller (BDC)
4	Lighting, exterior mirror, front right
5	Lighting, exterior mirror, rear right
6	Lighting, exterior mirror, rear left
7	Driver's exterior mirror with projector
8	Lighting, exterior mirror, front left
9	Lighting, center stack

2.2.2. Rear seats

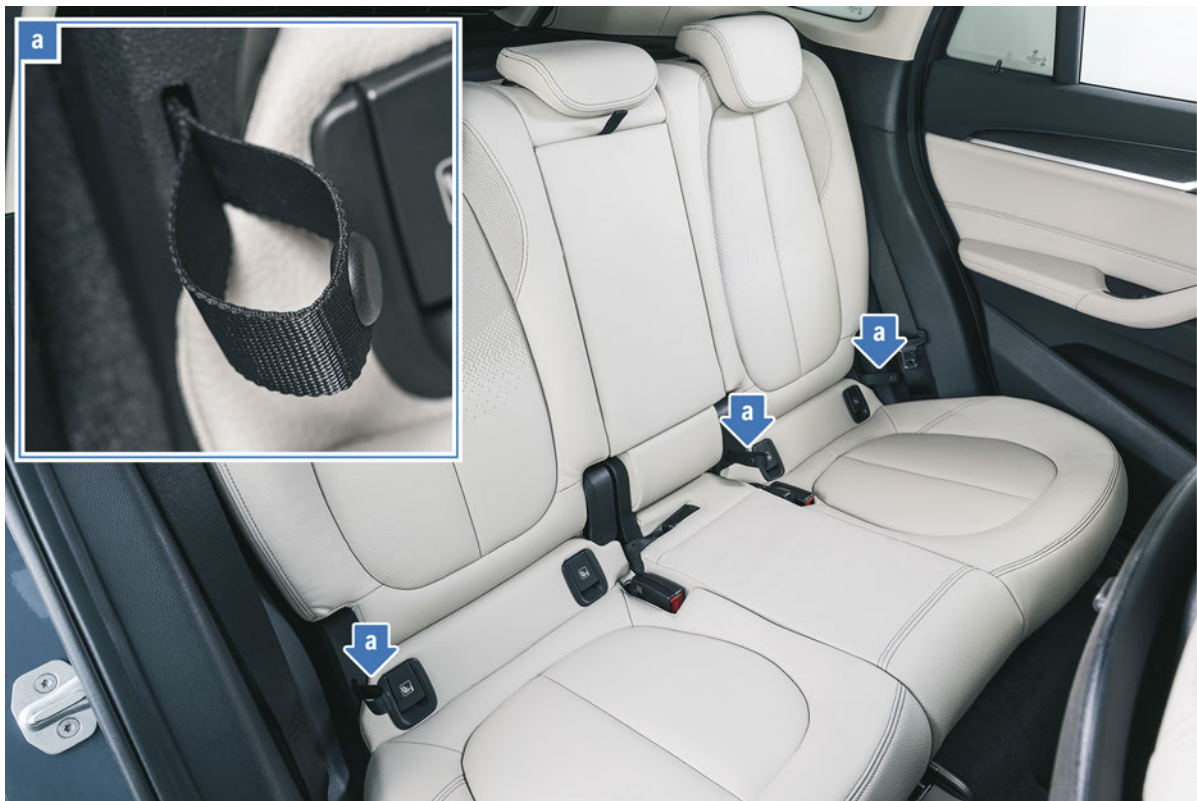

Unlocking of rear seat backrests

The rear seat backrest is divided 40:20:40 as standard, whereby each rear seat backrest can be folded separately. The backrest is released by using a loop at the respective rear seat backrest lower section.

F48 LCI Complete Vehicle

3. Drivetrain

3.1. Gasoline engine

The following table features an overview of the engine used.

Model	Engine	Power in [kW (hp)]	Torque in [Nm (lb-ft)]
xDrive28i	B46A2001	170 (228)	350 (258)
sDrive28i	B46A2001	170 (228)	350 (258)

3.1.1. Coolant bleeding routine of B46TU engine



When components are replaced in the cooling system or the system was filled, an automated coolant bleeding routine must be carried out. Otherwise, there is the risk of engine damage.

During the automated coolant bleeding routine, the actuators in the cooling system as well as the different engine speeds are activated. The automated coolant bleeding routine takes roughly 8 minutes.

The following prerequisites must be fulfilled to be able to perform an automated coolant bleeding routine in the vehicle:

- Correct coolant level
- Hood closed
- Terminal 15 active
- ECO PRO driving mode **inactive**
- Maximum temperature adjusted at the heating and air conditioning controls
- Lowest blower speed set

Proceed as follows to start the automatic coolant bleeding routine:

- Press accelerator pedal for 10 s (do **not** press brake pedal)
- Start the engine (ensure that the parking brake is applied and the gearshift lever is in idle position or the selector lever is in the "N" or "P" position).

The starting and ending of the automated coolant bleeding routine is displayed in the instrument cluster.

3.2. Antifreeze and corrosion inhibitor

The cooling system is filled with the new antifreeze and corrosion inhibitor Frostox HT-12®. It increases the long-term stability and corrosion protection of the components and replaces the familiar antifreeze and corrosion inhibitor Glysantin G48®.

F48 LCI Complete Vehicle

3. Drivetrain



Antifreeze and corrosion inhibitors cannot be mixed with each other in any manner. If they are mixed, it may cause the antifreeze and corrosion inhibitor to gel, thus causing engine damage.

The selection of the correct antifreeze and corrosion inhibitor is only possible via the workshop information system using the part number.

3.3. Automatic engine start/stop function

The automatic engine start-stop function (MSA) of the F48 LCI is complemented by the MSAconnected 1.0.

With MSAconnected 1.0 it is possible to predict a possible stop duration with information from the navigation system and/or the camera-based assistance systems. The automatic engine start-stop function responds differently depending on the length of the stop:

- **Briefly stop of the vehicle**
Example: Stop sign
The effort for an engine start is greater than the fuel economy by the engine shutdown.
- **Long vehicle stop**
Example: Stop at traffic lights
The improvement to the fuel economy as a result of the engine shutdown is greater than the effort generated by the engine start.

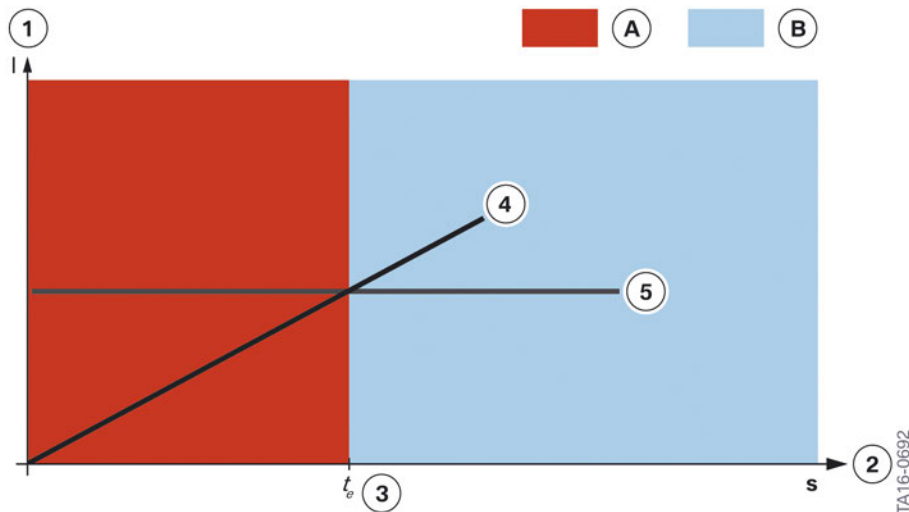

MSAconnected 1.0, stop strategy

F48 LCI Complete Vehicle

3. Drivetrain

Index	Explanation
A	Inefficient stop
B	Efficient stop
1	Fuel saving in liters
2	Time in seconds
3	Efficient time
4	Consumption benefit due to engine start-stop function
5	Effort needed for engine start

The frequency of inefficient engine start-stop operations is reduced by predicting engine shutdowns and starts according to various situations.

3.3.1. Advantages

The use of MSAconnected 1.0 results in the following advantages for the automatic engine start-stop function in the areas of "efficiency" and "dynamics".

Efficiency

- Short, inefficient engine shutdowns are avoided.

Dynamic

- The drive-off response is improved by preventing the automatic engine start-stop function from starting and stopping in MSAconnected 1.0 situations
- Drive-off reminder "Vehicle in front is driving off"
- The number "reflex starts due to the driver changing their mind" is reduced.

3.3.2. Notes for Service



Due to the navigation maps not being up-to-date, there may be limitations in the MSAconnected 1.0 functions. It is important to make sure that the navigation map data in the head unit is always up-to-date.



Before diagnosis for any complaint related to MSAconnected 1.0, a check must be carried out to see if the problem could have been caused by a system-related restriction. In this case, a repair measure would not resolve the issue.

F48 LCI Complete Vehicle

3. Drivetrain

3.4. Transmission

The following table provides an overview of the transmission for the F48 LCI:

Model	Automatic transmission
xDrive28i	GA8Y45EW
sDrive28i	GA8Q45EW

3.4.1. Gear selector lever

An electronic gear selector lever is now used.. It was 1st used in the F39 X2 M35i. The gear selector switch is designed as a separate control unit and comprises the control electronics and the selector lever. The control electronics detects the movement of the selector lever using sensors. The change of the drive position is identified by means of hall effect sensors and the signals are sent to the transmission control via PT-CAN2.

Additional information on the electronic gear selector lever (GWS) can be found in ST1845 F39 X2 M35i Transmission.



Gear selector switch

TE19-0552

F48 LCI Complete Vehicle

3. Drivetrain

System wiring diagram

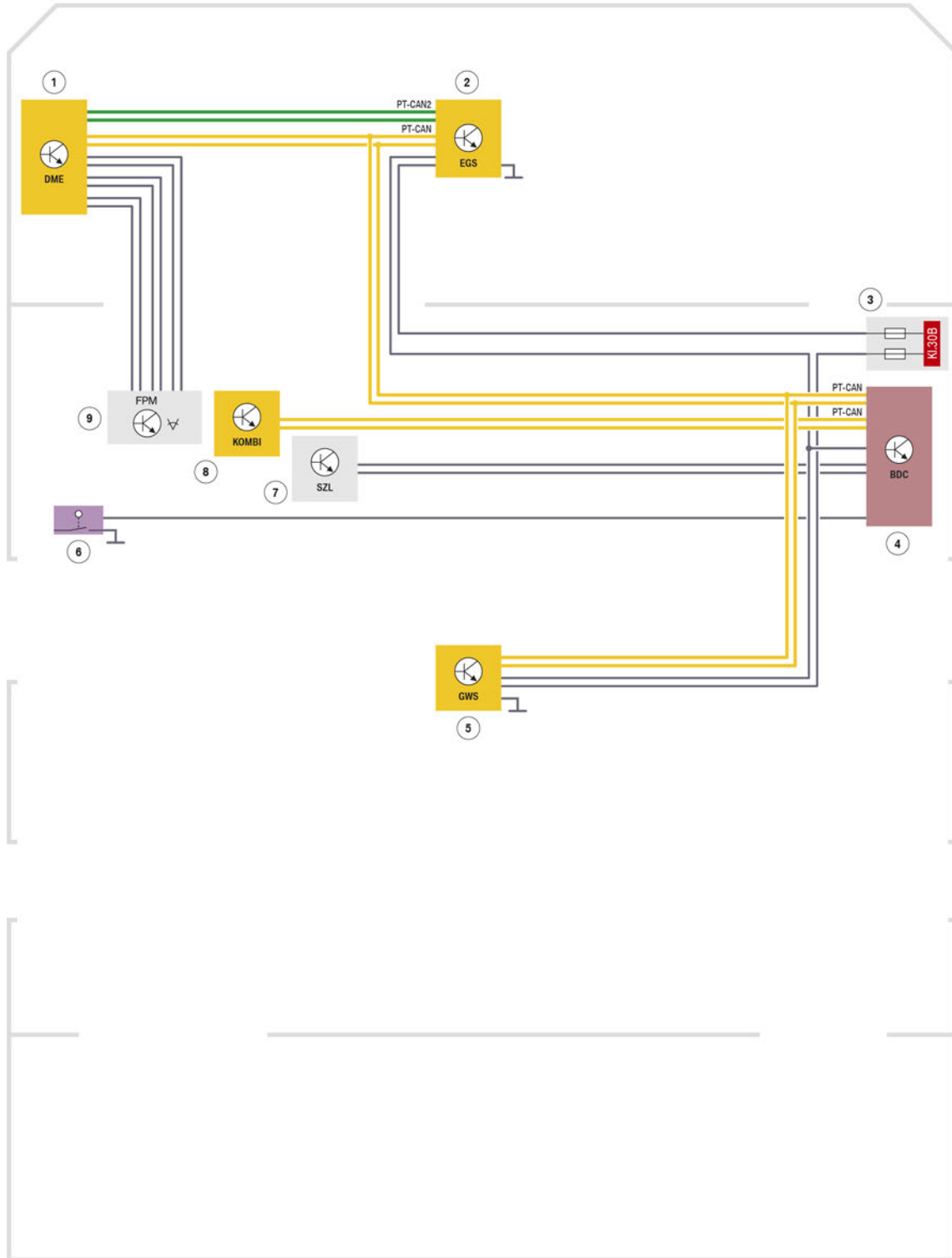

Gear selector switch (GWS)

TA19-0302_2

F48 LCI Complete Vehicle

3. Drivetrain

Index	Explanation
1	Digital Motor Electronics (DME)
2	Electronic transmission control (EGS)
3	Fuses in the power distribution box, front right
4	Body Domain Controller (BDC)
5	Gear selector switch (GWS)
6	Brake light switch
7	Steering column switch cluster (SZL)
8	Instrument cluster (KOMBI)
9	Accelerator pedal module

3.4.2. ConnectedShift

Use of the navigation data

To reduce the gearshifts in bends and optimize the driving dynamics, the system takes into consideration the route information of the navigation system for shifting. If the system detects a section with a tight curve, the transmission shifts down early and holds the last selected gear in the curve. As a result, the speed of the vehicle is sharply reduced with help of the engine drag torque and the holding of the gear in the curve makes possible optimal acceleration at the end of the curve. ConnectedShift is different depending on the selected mode (SPORT, COMFORT). ConnectedShift is not active in ECO PRO mode.

The route guidance of the navigation system is not required for ConnectedShift. The navigation map version and activation of the turn indicator when turning contribute to more precise control of the system.

Use of the camera

In addition to the navigation data, ConnectedShift in the F48 LCI uses the KAFAS camera. If the front camera detects a vehicle ahead and if a critical distance is undershot with a large speed difference, the camera-based ConnectedShift is activated. The system no longer shifts to higher gears and supports the driver with active downshifting with the reduction of the vehicle speed. Higher power reserves are also available at a lower gear for any overtaking.

ConnectedShift is different depending on the mode (SPORT, COMFORT). In ECO PRO mode ConnectedShift is not active.

ConnectedShift is only available with the Active cruise control with Stop & Go function.

F48 LCI Complete Vehicle

3. Drivetrain

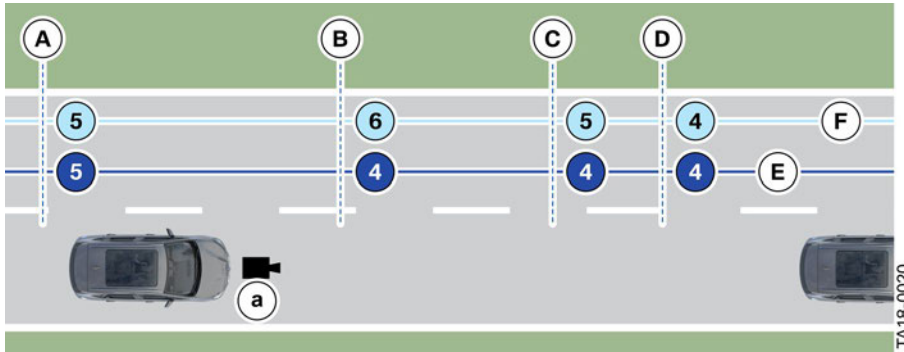

Gear selection with and without camera-based ConnectedShift

Index	Explanation
A	High excess speed and critical distance undershot
B	Driver steps off the gas
C	Driver brakes
D	Driver accelerates and overtakes
E	Gear selection with preview
F	Gear selection without preview
a	Object detection via camera (only available in combination with Active cruise control with Stop & Go function)
4	Gear 4
5	Gear 5
6	Gear 6

F48 LCI Complete Vehicle

4. General Vehicle Electronics

4.1. Bus overview

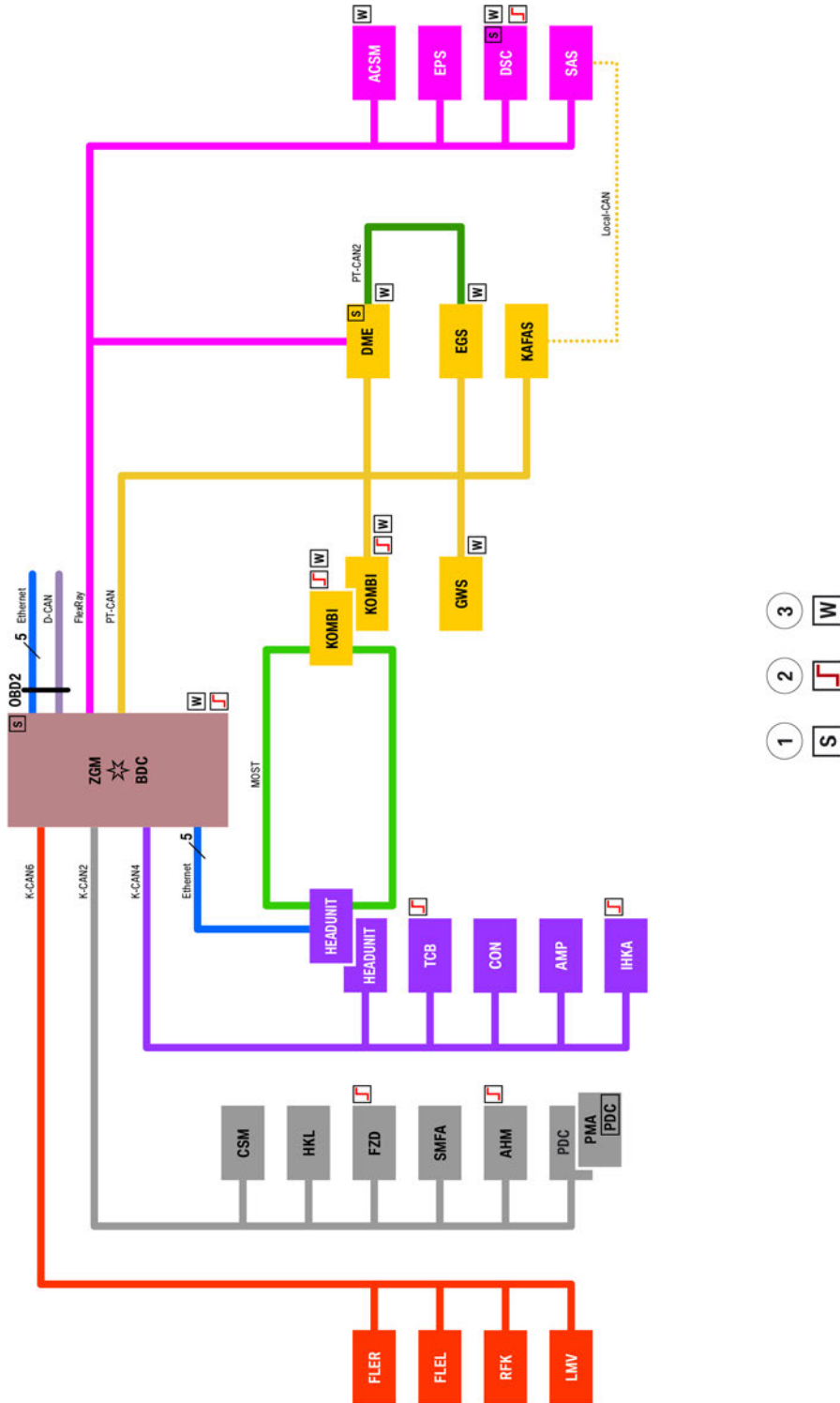

Bus overview

F48 LCI Complete Vehicle

4. General Vehicle Electronics

Index	Explanation
ACSM	Advanced Crash Safety Module
AHM	Trailer module
AMP	Amplifier
BDC	Body Domain Controller
CON	Controller
CSM	Car Sharing Module
DME	Digital Motor Electronics
DSC	Dynamic Stability Control
EGS	Electronic transmission control (EGS)
EPS	Electronic Power Steering
FLEL	Frontal Light Electronics Left
FLER	Frontal Light Electronics Right
FZD	Roof function center
GWS	Gear selector switch
HEAD UNIT	HEAD UNIT
HKL	Automatic luggage compartment lid actuation
IHKA/IHKS	Integrated automatic heating/air conditioning system / Integrated heating and air conditioning control
KAFAS	Camera-based driver assistance systems
KOMBI	Instrument panel
LMV	Longitudinal torque distribution
PDC/PMA	Park Distance Control/Parking Manoeuvring Assistant
RFK	Rear view camera
SAS	Optional equipment system
SMFA	Driver's seat module
TCB	Telematic Communication Box
1	Start-up node control units for starting and synchronizing the FlexRay bus system
2	Control units authorized to perform wake-up function
3	Control units also connected at terminal 15WUP

F48 LCI Complete Vehicle

4. General Vehicle Electronics

4.2. Alternator

In the F48 LCI, AGLR alternators (active rectification) with increased efficiency are used. The increase in the alternator's efficiency is achieved by reducing the losses in the rectifier. The diodes with losses are replaced with activated MOSFETs (**M**etal **O**xide **S**emiconductor **F**ield **E**ffect **T**ransistors). A reduction in fuel consumption is achieved by increasing the efficiency.

4.3. Battery

Depending on the model, optional equipment and country, either an AGM battery or a special lead-acid battery is installed. This new lead-acid battery is called an **Enhanced Flooded Battery (EF-battery)**.

4.3.1. Enhanced Flooded Battery

Compared with a traditional lead-acid battery, an EF-battery has double the cycle stability and is therefore ideal for vehicles with an automatic engine start-stop function. An EF-battery is also lighter and has a higher temperature resistance than an AGM battery.

The EF-battery can be recognized from the white housing and black lid that includes a Sight glass.

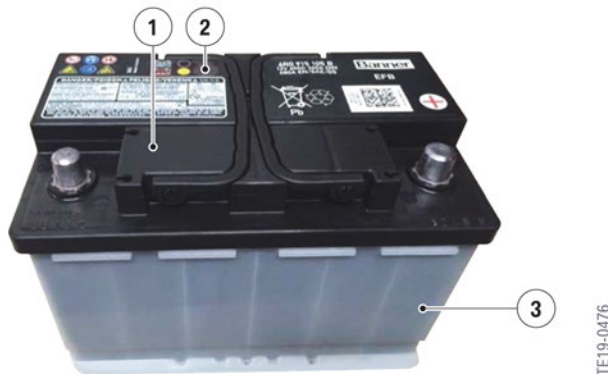

EF-battery

Index	Explanation
1	Black lid
2	Sight glass
3	White housing

The EF-battery has a polyester mesh on the positive electrodes. As a result, the stability of the plates within the battery is increased and the service life of the battery is extended.

Service instruction

Like for AGM batteries, an energy diagnosis must be performed using ISTA for vehicles with a flat or defective EF-battery.

F48 LCI Complete Vehicle

4. General Vehicle Electronics

4.4. Exterior lights

4.4.1. Headlight

LED Headlights with Cornering Lights (SA 5A4) are available as an option. The revision of the design of the LED headlight ensures a modern and sporty look.

The functions of the respective headlights are set out in the following table:

	LED headlights	LED Headlights with cornering lights (SA 5A4)
Automatic LED headlights	X	X
Adaptive light		X
Cornering light		X
Automatic high-beams		X

LED headlight with cornering light



LED headlight with cornering light

TE19-0553

F48 LCI Complete Vehicle

4. General Vehicle Electronics

Index	Explanation
1	Cornering light
2	Turn indicator
3	Low-beam headlight
4	High beam
5	Daytime driving lights/Side lights

The LED headlights with cornering lights has the following functions:

- Adaptive lights
- Cornering lights

4.4.2. Rear lights

The differentiation of the headlights is continued at the rear lights. All lighting functions are designed as halogen headlights in the basic equipment. The tail light and brake light functions are illuminated with a two-stage bulb. The functions of the rear lights are also carried out in full LED in conjunction with LED headlights.

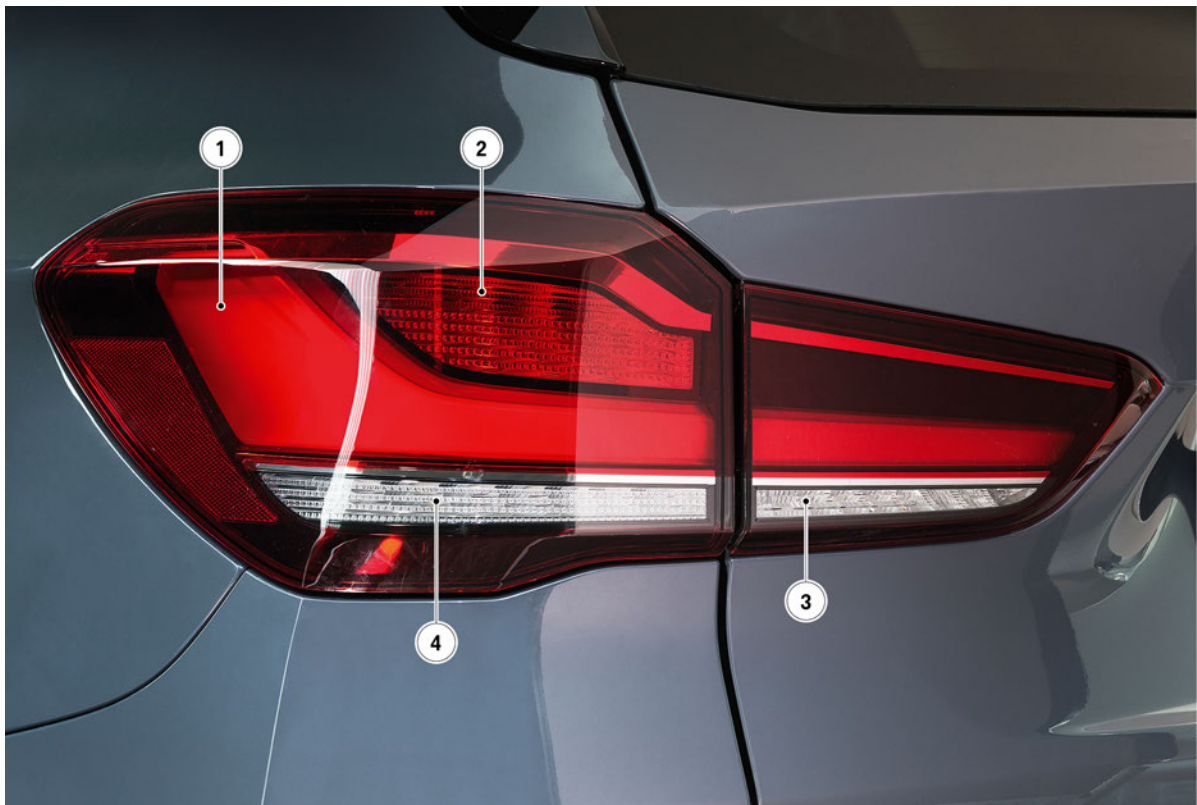

Full LED rear light

F48 LCI Complete Vehicle

4. General Vehicle Electronics

Index	Explanation
1	Tail light
2	Brake light
3	Reversing light
4	Turn indicator

4.5. Assistance systems

The following assistance systems are available for the F48 LCI:

- Dynamic Cruise Control with braking function (Standard)
- Active cruise control with Stop & Go + Active Driving Assistant (OE 5AT)
- Park Distance Control (PDC) front and rear (Standard)
- Parking Assistant (OE 5DP)
- Rear view camera (Standard)
- ConnectedDrive Services (Standard)
- Active Driving Assistant (Standard)

4.5.1. Driving Assistant

Active Driving Assistant (SA 5AS) is standard on the F48 LCI, ACC Stop & Go + Active Driving Assistant (SA 5AT) is optional. The following table displays which system is included in the packages:

System	Active Driving Assistant (SA 5AS)	ACC with Stop & Go + Active Driving Assistant (SA 5AT)
Active cruise control with Stop & Go function		X
Speed limit info	X	X
Lane departure warning	X	X
Frontal collision warning with braking	X	X
High-beam assistant	X	X

4.6. Infotainment

F48 LCI Complete Vehicle

4. General Vehicle Electronics

4.6.1. Wireless charging



Wireless charging station, center console

With corresponding equipment the wireless charging station is located in the center armrest, as already known from other series. This replaces the base plate of the snap-in adapter, which is no longer available.

The optional equipment of the "Wireless charging" (SA 6NW) contains the following features and properties:

- Connection to the external antenna of the vehicle
- Wireless charging for qi-compatible devices
- Simultaneous pairing of 2 mobile phones and an audio device
- Additional microphone on the passenger's side for improved hands-free system
- Wi-Fi hotspot
- USB Type-A center stack
- USB Type-C center console

Like since 07/2018, in the F48 LCI the antenna amplifier between the telephone antenna and the wireless charging station is deleted. There is a direct connection of the antenna line to the wireless charging station.

F48 LCI Complete Vehicle

4. General Vehicle Electronics

System wiring diagram

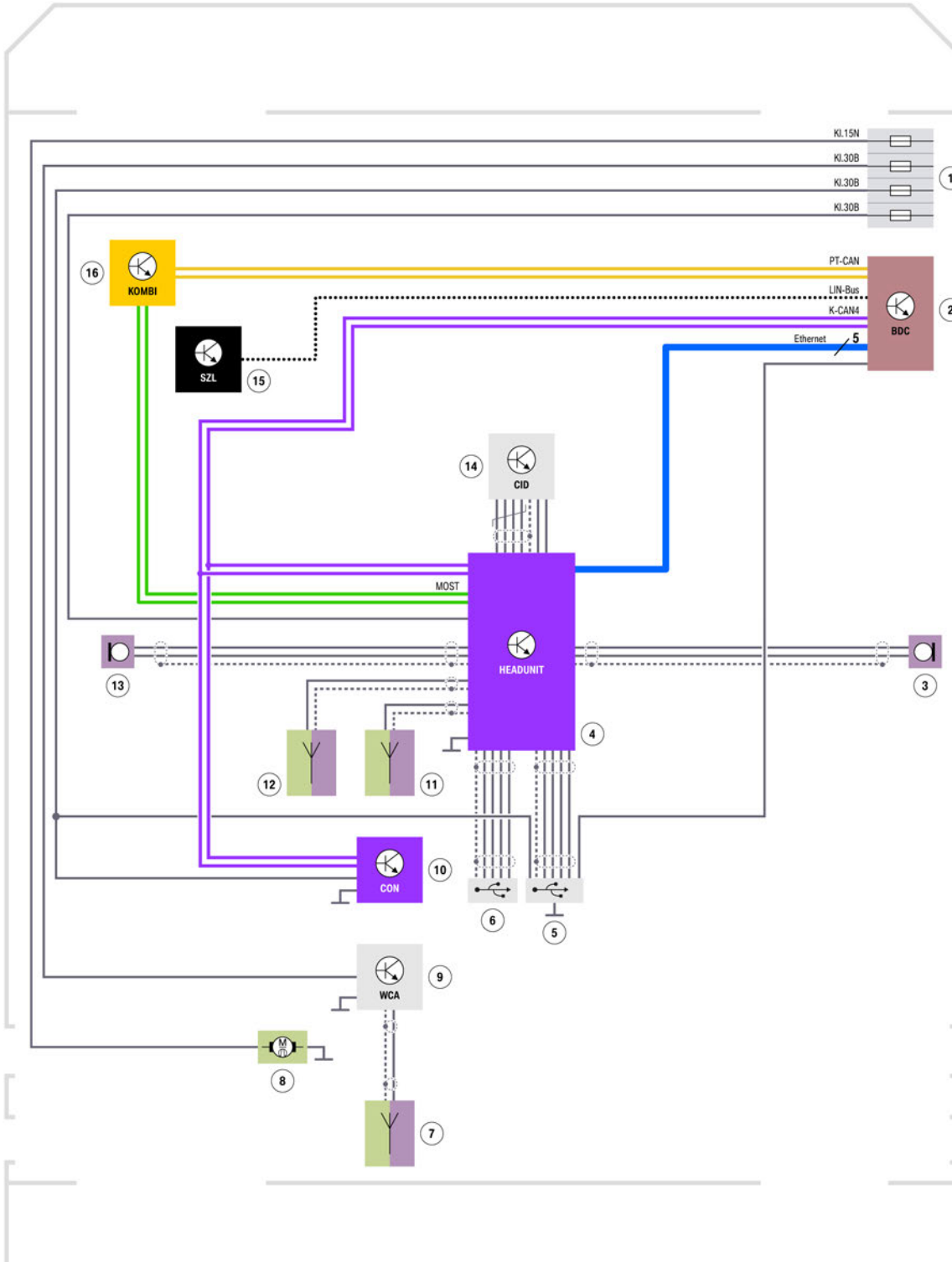

TE19-0294

Telephony with wireless charging

F48 LCI Complete Vehicle

4. General Vehicle Electronics

Index	Explanation
1	Front power distribution box, front passenger
2	Body Domain Controller (BDC)
3	Microphone 2
4	Head Unit Basic 2 (HU-B2)
5	USB Type-C center console
6	USB Type-A center stack
7	Roof antenna
8	Center armrest storage compartment fan
9	Wireless charging station
10	Controller
11	WLAN antenna
12	Bluetooth antenna
13	Microphone 1
14	Central Information Display (CID)
15	Steering column switch cluster (SZL)
16	Instrument cluster (KOMBI)

Status LED

The status of the wireless charging tray is indicated by an LED.

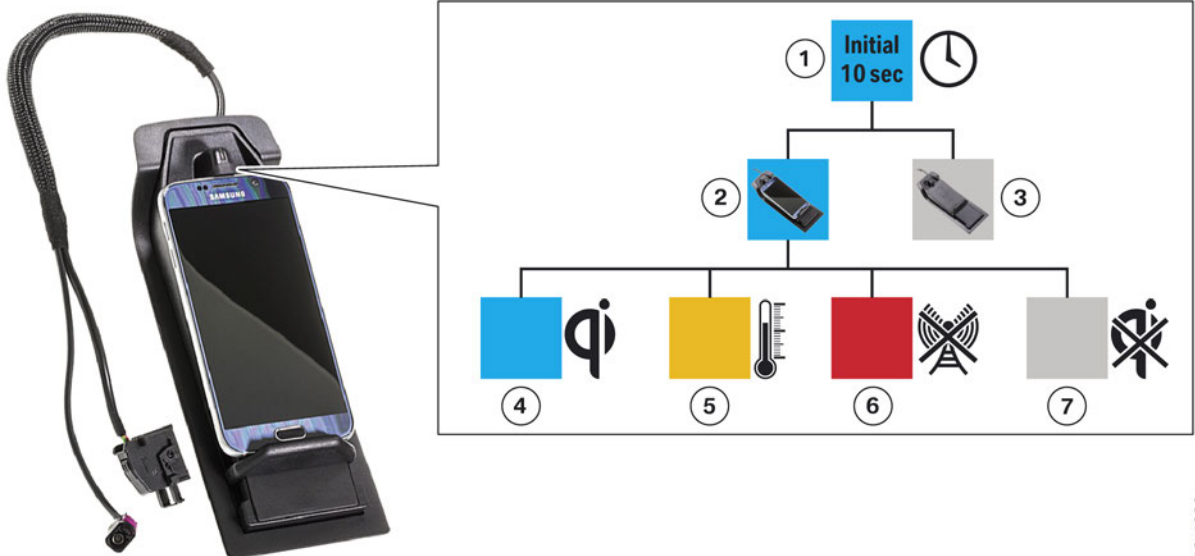

Wireless charging status LED

TE16-1229

F48 LCI Complete Vehicle

4. General Vehicle Electronics

Index	Explanation
1	Self-diagnosis
2	Check for mobile phone compatibility
3	Not possible to charge (e.g. mobile phone not compatible)
4	Mobile phone is charging
5	Not possible to charge (e.g. temperature of the charging electronics in the mobile phone is too high or foreign bodies detected)
6	Charging not possible (fault with the antenna system)
7	Not possible to charge (e.g. mobile phone fully charged)

4.6.2. USB interfaces

Depending on the equipment, the F48 LCI is equipped with the USB variants Type-A and Type-C. The USB ports can be in the center stack, the center console and in the rear passenger compartment.

The following table provides an overview of the USB ports:

Equipment	Center Stack	Center console	Rear
Storage package (Standard) ¹	-	Type-A, charging/data transfer	Dual charger Type-C, charging
Wireless charging (SA 6NW)	Type-A, charging/data transfer	Type-C, charging/data transfer	Dual charger Type-C, charging

¹Standard equipment



USB Type-A center stack

F48 LCI Complete Vehicle

4. General Vehicle Electronics



USB Type-C center console under armrest



USB Type-C rear passenger compartment

	Data transfer	Charge current
USB Type-A	USB 2.0	1.5 A
USB Type-C	USB 3.0	3.0 A
USB dual charger Type-C	USB 3.0	3.0 A

F48 LCI Complete Vehicle

4. General Vehicle Electronics



USB connector

Index	Explanation
A	USB Type-A
B	USB Type-C

4.6.3. Head unit

The following table gives you an overview of the specific configuration of the head unit, the Central Information Display (CID) and the instrument cluster (KOMBI).

Equipment	Head unit	CID	KOMBI
Navigation	Head Unit Basic 2	8.8" touch display	5.7" TFT display

4.6.4. Controller

The touch function for the controller is deleted in the F48 LCI. A controller with 5 direct access keys is used with the standard equipment "Navigation Business" or the optional "Navigation" with 7 direct keys on the controller. (SA 6UP).

4.6.5. User interface

Since 07/2017, in the BMW X1 the user interface ID6 (BMW iDrive in the 6th generation) is used. This is also continued in the F48 LCI.

Head unit	User interface	8.8 inch Touch screen
HU-B2	ID 6	

The user interface is designed for iDrive control using the controller and for direct touch control by touching the CID screen.

F48 LCI Complete Vehicle

4. General Vehicle Electronics

4.7. ID transmitter

The ID transmitter is equipped with a motion sensor for improved theft-proofing. If it is not moved for around 2 minutes, the ID transmitter switches itself off. While the ID transmitter is asleep, it cannot be activated via radio signals. As a result, the ID transmitter also cannot be accessed via a range extender (artificial extension of the transmission path). The ID transmitter only wakes up if a movement occurs or if a button is pressed.

It is easy to check whether an ID transmitter is fitted with a motion sensor. This is done by removing the cover of the battery compartment and reading off the ID number.

- Without motion sensor: ID2A
- With motion sensor: ID21A CA.



F48 LCI ID transmitter

TE18-2582

