

Reference Manual



N63TU3 ENGINE



Technical Training

The information contained in this manual is not to be resold, bartered, copied or transferred without the express written consent of BMW of North America, LLC ("BMW NA").

Copyright © 2018 BMW of North America, LLC

Technical training.
Product information.

N63TU3 Engine



BMW Service

Edited for the U.S. market by:
BMW Group University
Technical Training

ST1854

10/1/2018

General information

Symbols used

The following symbol is used in this document to facilitate better comprehension or to draw attention to very important information:



Contains important safety information and information that needs to be observed strictly in order to guarantee the smooth operation of the system.

Information status: July 2018

BMW Group vehicles meet the requirements of the highest safety and quality standards. Changes in requirements for environmental protection, customer benefits and design render necessary continuous development of systems and components. Consequently, there may be discrepancies between the contents of this document and the vehicles available in the training course.

The information contained in the training course materials is solely intended for participants in this training course conducted by BMW Group Technical Training Centers, or BMW Group Contract Training Facilities.

This training manual or any attached publication is not intended to be a complete and all inclusive source for repair and maintenance data. It is only part of a training information system designed to assure that uniform procedures and information are presented to all participants.

For changes/additions to the technical data, repair procedures, please refer to the current information issued by BMW of North America, LLC, Technical Service Department.

This information is available by accessing TIS at www.bmwcenternet.com.

Additional sources of information

Further information on the individual topics can be found in the following:

- Owner's Handbook
- Integrated Service Technical Application
- Aftersales Information Research (AIR)

The information contained in this manual is not to be resold, bartered, copied, or transferred without the express written consent of BMW of North America, LLC (“BMW NA”).

©2018 BMW of North America, LLC

The BMW name and logo are registered trademarks. All rights reserved.

N63TU3 Engine

Contents

1. Introduction	1
1.1. Models with N63B44M3 engine	1
1.2. Models with N63B44T3 engine	1
1.3. Technical data	2
1.3.1. Full load diagram N63B44M3 engine	3
1.3.2. Engine highlights N63B44M3	4
1.3.3. Full load diagram N63B44T3 engine	5
1.3.4. Engine highlights N63B44T3	6
1.3.5. Comparison of components with N63TU2 engine	7
1.4. Engine identification	12
1.4.1. Engine identification	12
1.4.2. Engine identification	13
2. Engine Mechanical	14
2.1. Engine housing	14
2.1.1. Crankcase	14
2.1.2. Cylinder head gasket	15
2.1.3. Cylinder head	15
2.1.4. Cylinder head cover	16
2.2. Crankshaft	17
2.2.1. Connecting rod with bearing	18
2.2.2. Piston with piston rings	19
2.3. Camshaft drive/chain drive	21
3. Oil Supply	23
4. Intake and Exhaust System	24
4.1. Air mass determination	24
4.2. Intake air monitoring	24
4.3. Crankcase ventilation monitoring system	25
4.4. Exhaust turbochargers N63B44M3	28
4.4.1. Overboost	29
4.5. Exhaust turbocharger in the N63B44T3 engine	30
4.5.1. Blow-off control	31
4.6. Exhaust emission system	31
4.6.1. Exhaust manifold	31
4.6.2. Catalytic converters	31
4.6.3. Exhaust system	31
5. Cooling	32
5.1. Charge air cooler	33

N63TU3 Engine

Contents

6.	Fuel Preparation	34
6.1.	Overview.....	34
6.2.	Fuel pump control.....	35
6.3.	High pressure pump.....	35
6.4.	Injectors.....	35
7.	Engine Electrical System	38
7.1.	Engine control unit.....	38
7.1.1.	DME 1 control unit.....	39
7.1.2.	DME 2 control unit.....	42
7.1.3.	Overall function.....	46
7.2.	Ignition coils.....	46
7.3.	Spark plugs.....	48
8.	Engine Cover	49

N63TU3 Engine

1. Introduction

In the scope of a product update, as of November 2018 the BMW Group will be presenting a further development of the N63TU2/ engine originally introduced in July 2015. The N63TU3 engine will be used in 2 performance classes as N63B44M3 engine and N63B44T3 engine. The main developments in the N63TU3 engine compared to the N63TU2 engine are improved response characteristics, improved acoustics, increase in engine torque and lower pollutant emissions.

New features in the area of engine mechanics are reworked piston rings, reworked timing chains, reworked exhaust gas thermal management in the V-space, introduction of a "crosstalk point" in the intake area, increase in the fuel injection pressure of 200 bar to 350 bar and, in the area of the engine electrics, the introduction of a new Digital Motor Electronics. Critical components have been revised and newly implemented with a view to improving quality.

The new N63TU3 engine is being introduced for the first time as N63B44M3 engine for series production in the G05 and in the new G07. The N63B44T3 engine will be initially be introduced in the G15 at a later date.

The N63B44M3 engine will gradually be replaced by the N63B44T3 engine which means it will be phased out in the medium term.

Only the differences between the N63TU3 engine and N63TU2 engine are described in this document. A more in-depth documentation is provided in the product information for the N63TU2 engine in which a reference is provided at the relevant point.

1.1. Models with N63B44M3 engine

Development series	N63B44M3 engine	Series introduction
G05	BMW X5 xDrive 50i	08/2018
G07	BMW X7 xDrive 50i	12/2018

1.2. Models with N63B44T3 engine

Development series	N63B44T3 engine	Series introduction
G15	BMW M850i xDrive Coupé	10/2018
G14	BMW M850i xDrive Convertible	11/2018
G12	BMW 750i	03/2019

N63TU3 Engine

1. Introduction

1.3. Technical data

Engine	Unit	BMW X5 xDrive 50i N63B44M3	BMW M850i xDrive Coupé N63B44T3
Design		V8	V8
Displacement	[cc]	4395	4395
Firing order		1-5-4-8-6-3-7-2	1-5-4-8-6-3-7-2
Bore hole/Stroke	[mm]	89/88.3	89/88.3
Power output at engine speed	[kW (HP)] [rpm]	340 (456) 5250-6000 360 (490)* 5300-6000*	390 (523) 5500-6000
Power output per liter	[kW/l]	77.4	88.7
Torque at engine speed	[Nm (lb-ft)] [rpm]	650 (479) 1500-4750	750 (553) 1800-4600
Compression ratio	[ε]	10.5 : 1	10.5 : 1
Valves per cylinder		4	4
Recommended fuel	[ROz]	87-98	87-95
CO ₂ emissions	[grams per kilometer]	264	-**
Digital Motor Electronics		DME 8.8T.0	DME 8.8T.0

* with Overboost function

** values were still not available on the date the document was published.

N63TU3 Engine

1. Introduction

1.3.1. Full load diagram N63B44M3 engine

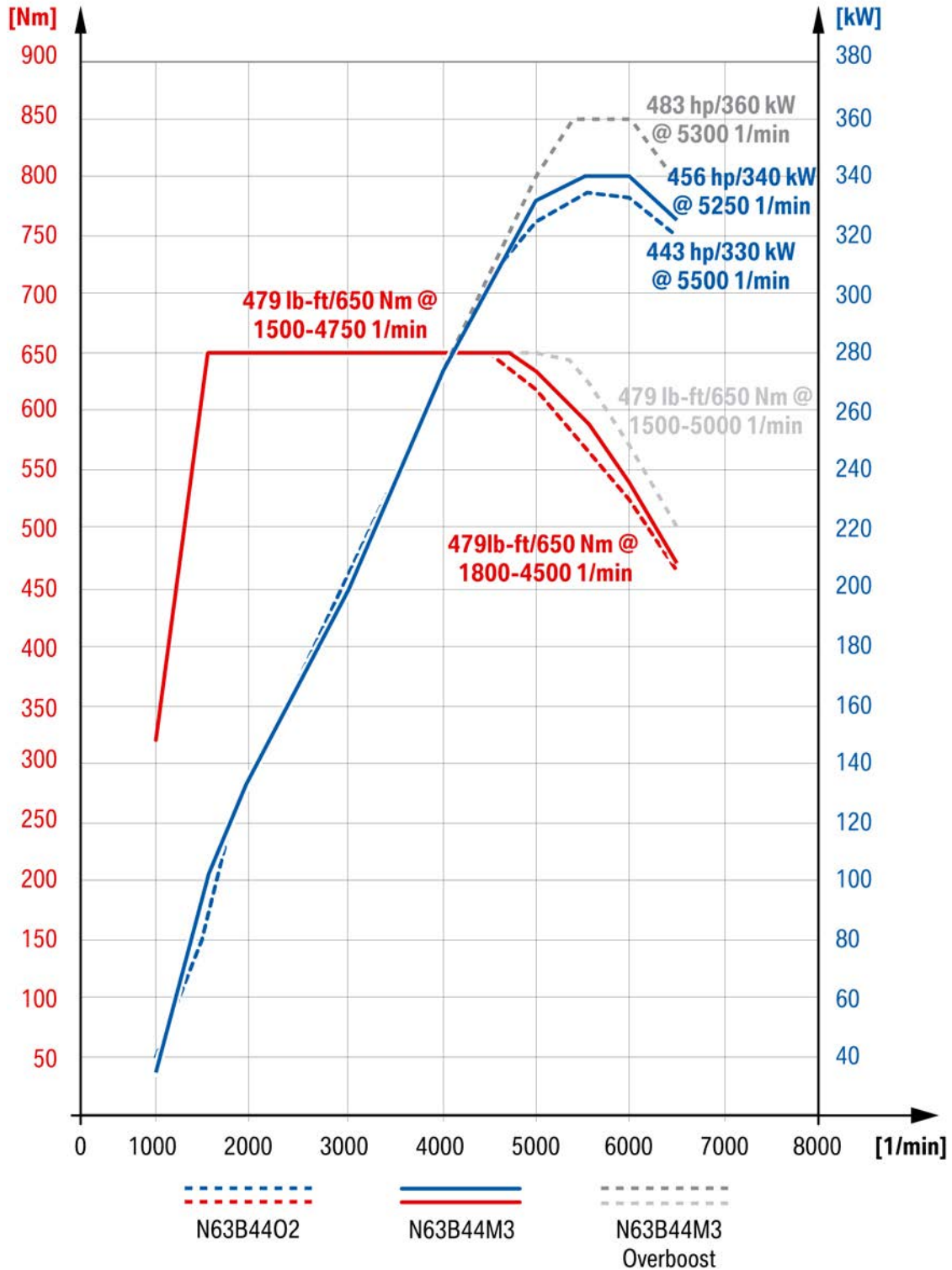

Full load diagram, N63B44O2 engine compared to the N63B44M3 engine

T018-0831_2

N63TU3 Engine

1. Introduction

1.3.2. Engine highlights N63B44M3



N63TU3 engine, Highlights N63B44M3 engine

Index	Explanation
A	Exhaust turbocharger with Overboost function
B	Indirect charge air cooler with bypass line
C	Digital Motor Electronics (DME 8.8T.0)
D	High-pressure injection up to 350 bar

N63TU3 Engine

1. Introduction

1.3.3. Full load diagram N63B44T3 engine

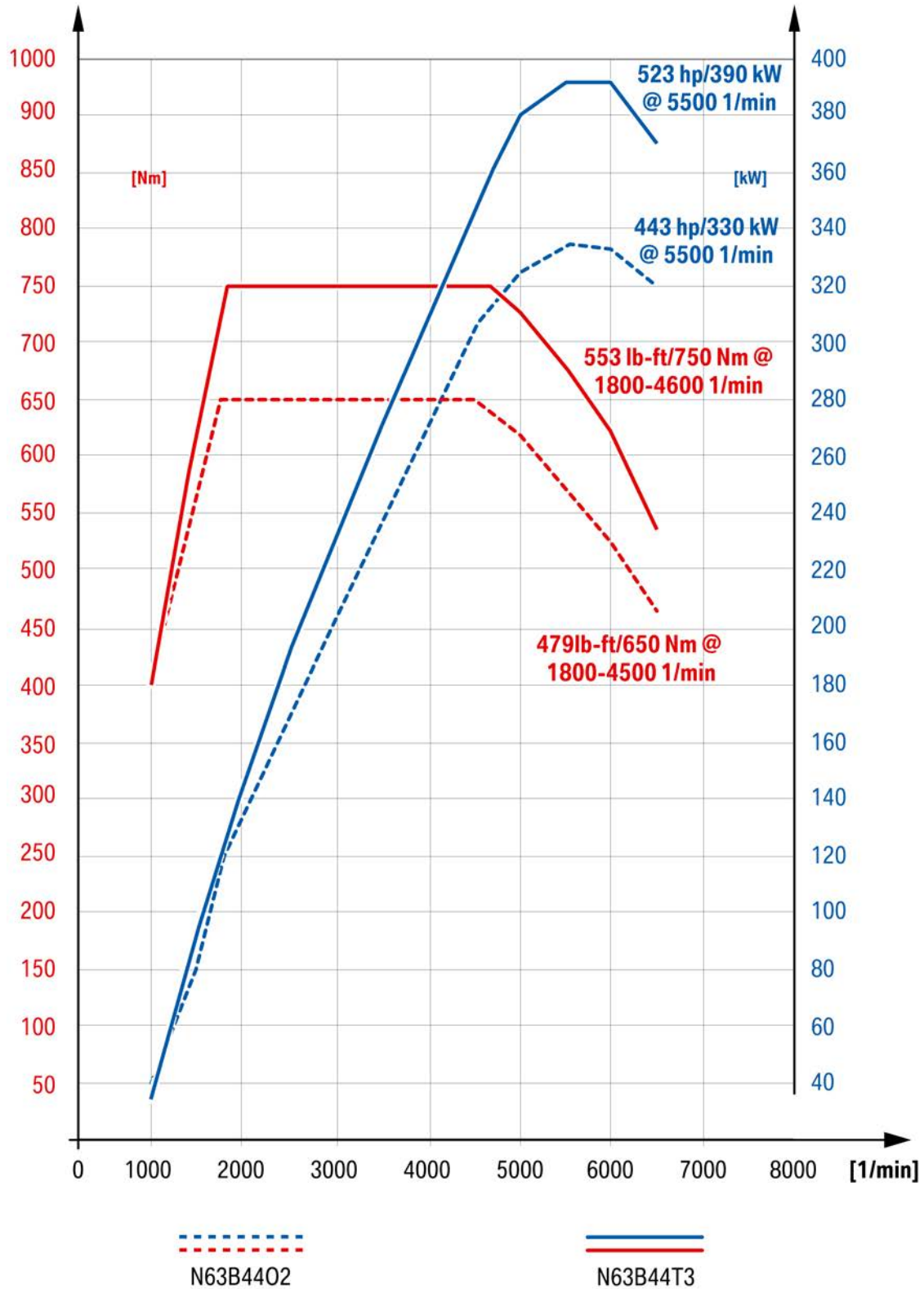

Full load diagram, N63B44O2 engine compared to the N63B44T3 engine

T018-0632_2

N63TU3 Engine

1. Introduction

1.3.4. Engine highlights N63B44T3

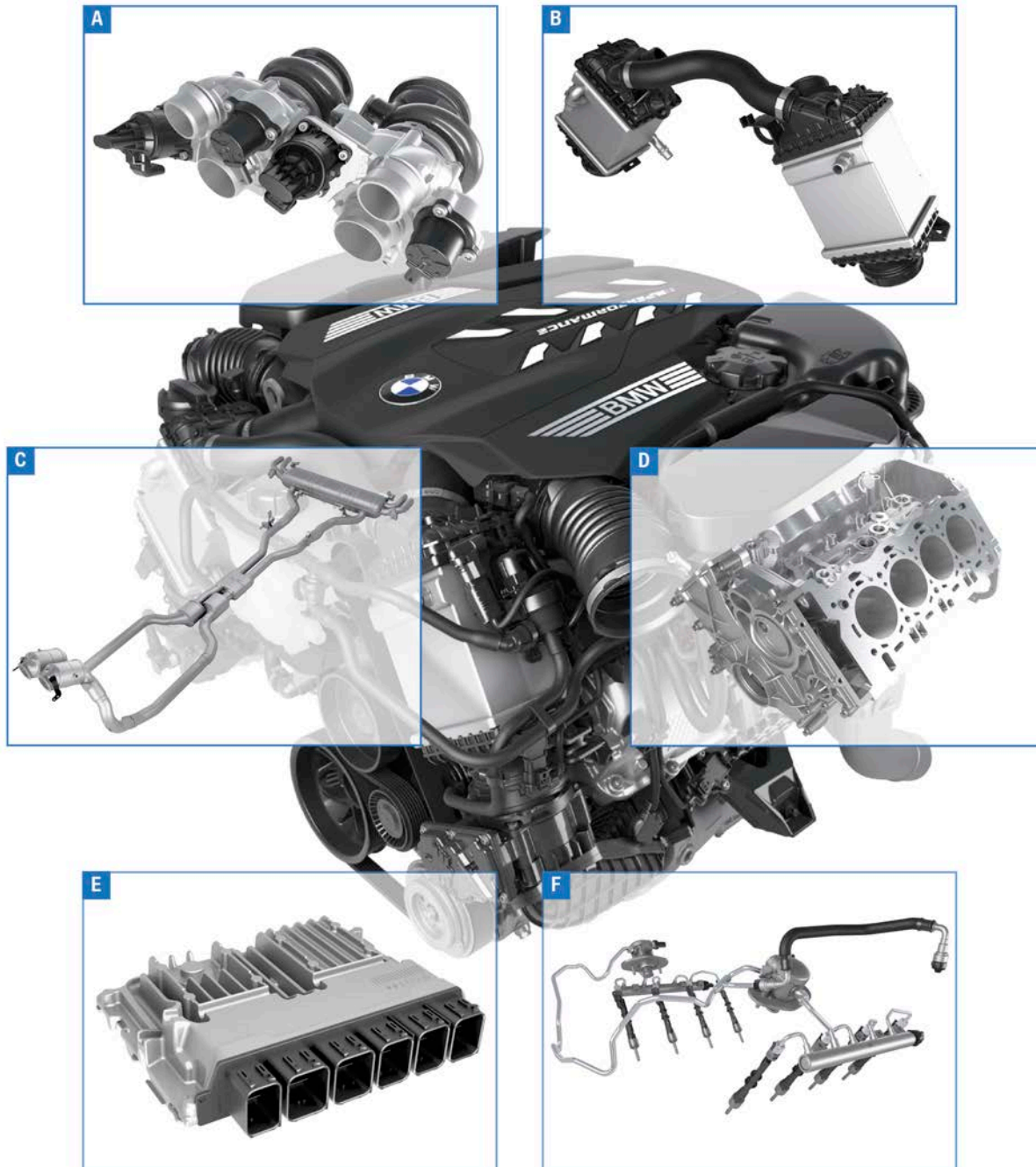

N63TU3 engine, Highlights N63B44T3 engine

TD18-0834

N63TU3 Engine

1. Introduction

Index	Explanation
A	Exhaust turbocharger with blow-off valves
B	Indirect charge air cooler with bypass line
C	Exhaust system with Gasoline particulate filter
D	Electric arc wire sprayed cylinder walls
E	Digital Motor Electronics (DME 8.8T.0)
F	High-pressure injection up to 350 bar

1.3.5. Comparison of components with N63TU2 engine

Engine mechanics

Component	New feature	Same concept	Carry-over part	Comment
Cylinder head cover	● N63B44T3 engine		● N63B44M3 engine	Cylinder bank 1 - additional sensor mounts and modification of ignition coil screw connections in the N63B44T3 engine, cylinder bank 2: taken over from S63B44T4 engine.
Cylinder head		●		Same concept as N63TU2 engine. Both engines feature cylinder heads of the N63B44T3 engine, geometrical modifications.
Cylinder head gasket	●			Reworking of cylinder head gasket due to higher outputs, modification of material.
Crankcase	● N63B44T3 engine		● N63B44M3 engine	Electric arc wire sprayed cylinder walls in N36B44T3 engine.
Crankshaft with main bearing		●		N63B44T3 engine: new main bearing shell materials introduced/ crankshaft rebalanced.
Connecting rod			●	Forged connecting rod of N63B44M3 engine taken over from S63TU2 engine, N63B44T3 engine: forged connecting rod taken over from S63TU4 engine.
Wrist pin			●	Taken over from N63TU2 engine.
Connecting rod bearing shells			●	Taken over from N63TU2 engine.

N63TU3 Engine

1. Introduction

Component	New feature	Same concept	Carry-over part	Comment
Piston	● N63B44T3 engine		● N63B44M3 engine	Piston skirt coating due to changeover to electric arc wire sprayed cylinder walls in the N63B44T3 engine.
Piston rings		●		Piston ring 1 and 2 taken over from N63TU2 engine, new oil scraper ring as U-Flex ring.
Flywheel			●	Carried over from N63TU2 engine.

Valve gear

Component	New feature	Same concept	Carry-over part	Comment
Chain drive with timing chain		●		Chain drive with timing chain reworked. Chromium nitride (CrN) coating of chain pin to reduce wear.
VANOS			●	Carried over from N63TU2 engine.
Fully variable valve lift adjustment			●	Carried over from N63TU2 engine.
Intake valves and exhaust valves			●	Carried over from N63TU2 engine.
Valve guides			●	Carried over from N63TU2 engine.
Valve stem seal		●		Material change. Resilience of valve stem seal increased to prevent hardening.
Camshafts		●		Intake camshaft: Carried over from N63TU2 engine. Exhaust camshaft: Carried over from S63TU4 engine

Belt drive and ancillary components

Component	New feature	Same concept	Carry-over part	Comment
Vibration damper			●	N63B44M3 engine: carried over from N63TU2 engine. N63B44T3 engine: carried over from S63TU4 engine.
Belt drive			●	Carried over from N63TU2 engine.

N63TU3 Engine

1. Introduction

Oil supply

Component	New feature	Same concept	Carry-over part	Comment
Oil pump			●	Carried over from N63TU2 engine.
Oil sump			●	Carried over from N63TU2 engine.
Oil filter module			●	Carried over from N63TU2 engine.
Oil spray nozzles			●	Carried over from N63TU2 engine.

Air intake and exhaust emission systems

Component	New feature	Same concept	Carry-over part	Comment
Intake manifold			●	Carried over from N63TU2 engine.
Exhaust manifold			●	Carried over from N63TU2 engine, hose clamp for connection of the twin-scroll exhaust turbocharger carried over from S63TU4 engine.
Exhaust turbocharger	● N63B44T3 engine		● N63B44M3 engine	Exhaust turbocharger carried over from N63TU2 engine in the N63B44M3 engine, but with Overboost function. New exhaust turbocharger in the N63B44T3 engine with electrical blow-off valves. New generation of bearing seats from the modular engines.
Exhaust turbocharger fluid lines		●		Improved thermal protection of fluid lines.
Heat shields			●	Carried over from N63TU2 engine, upper heat shield adapted to the relevant exhaust turbocharger.
Catalytic converter near engine			●	Carried over from N63TU2 engine.

N63TU3 Engine

1. Introduction

Fuel preparation

Component	New feature	Same concept	Carry-over part	Comment
High pressure pump	●			350 bar high pressure injection system.
Injectors	●			350 bar high pressure injection system.

Cooling

Component	New feature	Same concept	Carry-over part	Comment
Engine oil-to-coolant heat exchanger			●	Carried over from N63TU2 engine.
High-temperature circuit Engine cooling			●	Carried over from N63TU2 engine.
Mechanical Coolant pump			●	Carried over from N63TU2 engine.
Characteristic map thermostat			●	Carried over from N63TU2 engine.
Low-temperature circuit Charge air cooling			●	Carried over from N63TU2 engine.
Indirect charge air cooler	●			Bypass line between the two indirect charge air coolers.

Engine electrical system

Component	New feature	Same concept	Carry-over part	Comment
Digital Motor Electronics DME	●			DME 8.8T.0 Hardware from modular engines.
VANOS solenoid valves			●	Carried over from N63TU2 engine.
Valvetronic servomotor			●	Carried over from N63TU2 engine.

N63TU3 Engine

1. Introduction

Component	New feature	Same concept	Carry-over part	Comment
Oxygen sensors			●	Carried over from N63TU2 engine.
Ignition coils	● N63B44T3 engine		● N63B44M3 engine	Rod-type ignition coil from N63TU2 engine in N63B44M3 engine. (31 kV) Modular ignition coil introduced in the N63B44T3 engine. (42 kV)
Spark plugs	● N63B44T3 engine		● N63B44M3 engine	Carried over from N63TU2 engine in the N63B44M3 engine.
Knock sensors			●	Carried over from N63TU2 engine.
Oil temperature sensor			●	Carried over from N63TU2 engine.
Intake pipe pressure/temperature sensor			●	Carried over from N63TU2 engine.
Crankshaft sensor			●	Carried over from N63TU2 engine.
Camshaft sensor			●	Carried over from N63TU2 engine.
Coolant temperature sensor			●	Carried over from N63TU2 engine.
Oil pressure sensor	●			Oil pressure sensor with implemented damping element for improved sensor signal.
Oil-level sensor			●	Carried over from N63TU2 engine.
Rail pressure sensor			●	Carried over from N63TU2 engine.
Crankcase pressure sensor	●			The crankcase pressure is monitored by a crankcase pressure sensor.
Electronic wastegate valve actuator			●	Carried over from N63TU2 engine.

N63TU3 Engine

1. Introduction

Component	New feature	Same concept	Carry-over part	Comment
Starter motor			●	Carried over from N63TU2 engine.
Alternator			●	Carried over from N63TU2 engine.
Electronic throttle controller			●	Carried over from N63TU2 engine.

1.4. Engine identification

1.4.1. Engine identification

The N63TU3 engine in the form of the N63B44M3 engine variant and N63B44T3 engine variant is described in this document.

The engine identification is used in the technical documentation in order to clearly identify the engine.

Itemization

Index	Explanation
N	BMW Group "New Generation"
6	V8 engine
3	Engine with exhaust turbocharger, Valvetronic and direct fuel injection (TVDI)
B	Gasoline engine installed longitudinally
44	4.4 liters displacement
M/T	Medium performance class/top performance class
3	Third reworking

N63TU3 Engine

1. Introduction

1.4.2. Engine identification

The engines have an identification mark on the crankcase to ensure unambiguous identification and classification. This engine identification is necessary for approval by government authorities. The first six positions of the engine identification correspond to the engine designation.

The engine number can be found on the engine above the engine identification. This consecutive number, in conjunction with the engine identification, permits unambiguous identification of each individual engine.

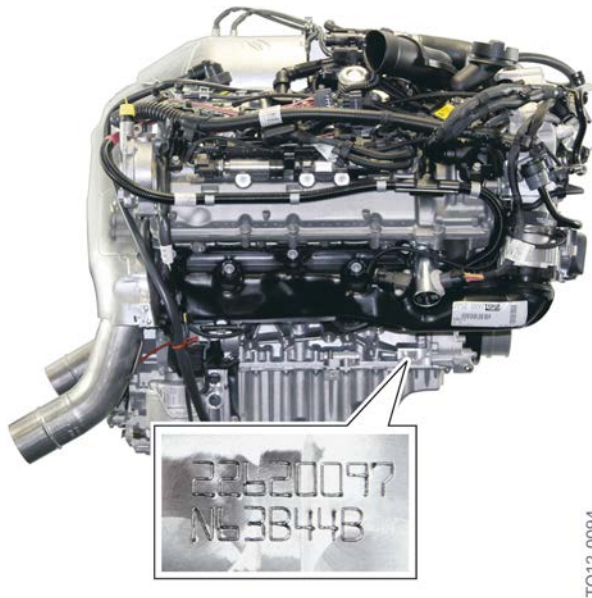

TO12-0094

Example of an N63TU engine, engine identification and engine number

Index	Explanation
22620097	Individual, consecutive engine number
N	BMW Group "New Generation"
6	V8 engine
3	Engine with exhaust turbocharger, Valvetronic and direct fuel injection (TVDI)
B	Gasoline engine installed longitudinally
44	4.4 liters displacement
B (D)	Type testing requirements, standard (code letter "D" is used for N63TU3 engine)

N63TU3 Engine

2. Engine Mechanical

2.1. Engine housing

The engine housing comprises the engine block, cylinder heads, cylinder head covers, oil sump and gaskets.



An oil dipstick along the same lines as the N63TU2 engine is installed.

2.1.1. Crankcase

The crankcase in the N63TU3 engine is manufactured from AISi17Cu4Mg low pressure die casting, same as the N63TU2 engine. The cylinder walls of the N63B44M3 engine are made of Alusil. The same electric arc wire sprayed cylinder walls that feature in the modular engines are used in the N63B44T3 engine. Like its predecessor in the N63TU2 engine, the closed-deck crankcase in the N63TU3 engine features a double main bearing screw connection with side wall connection.

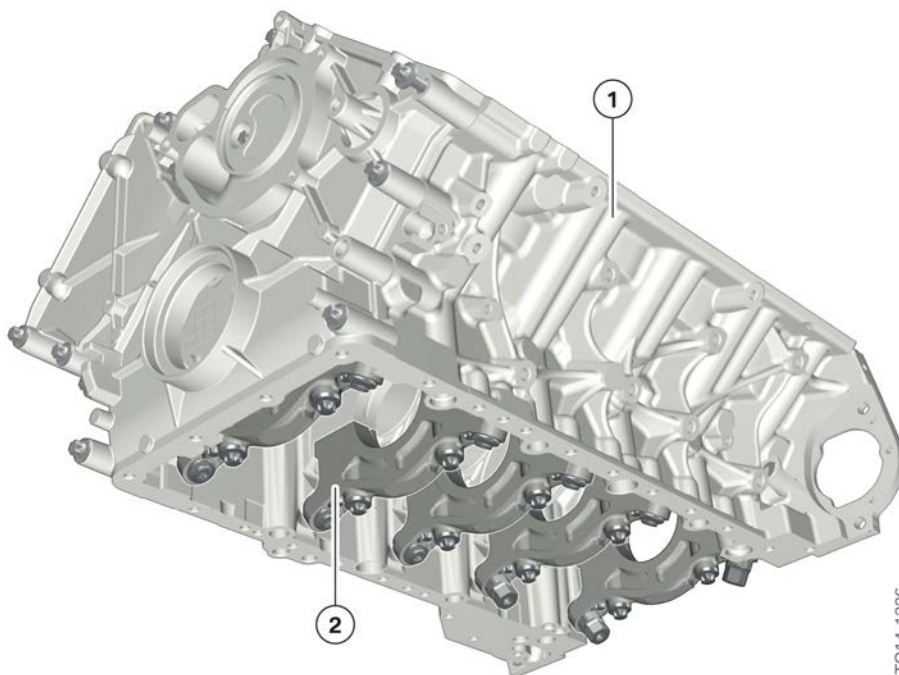

TO14-1326

N63TU3 engine, crankcase with screw connections

Index	Explanation
1	Crankcase
2	Double main bearing screw connection with side wall connection

The V-space in the N63TU3 is the same as the N63TU2 engine.

N63TU3 Engine

2. Engine Mechanical

2.1.2. Cylinder head gasket

As on the N63TU2 engine, a three-layer spring steel gasket is used for the cylinder head gasket. A reinforced stopper layer has been introduced in the N63TU3 in the area of the cylinder bores. The material thickness of the stopper plate has been increased to ensure sufficient contact pressure against the gasket.

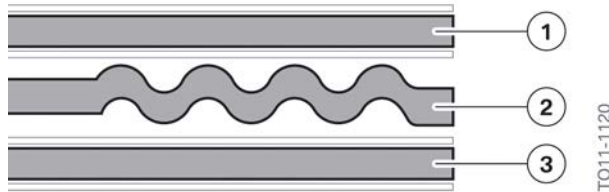

N63TU3 engine, cylinder head gasket

Index	Explanation
1	Top spring steel layer with anti-stick coating
2	Stopper layer
3	Bottom spring steel layer with anti-stick coating

2.1.3. Cylinder head

The concept of the cylinder head in the N63TU3 engine is the same as the N63T2 engine and also features the same partially integrated intake system. Thanks to this intake system partially integrated in the cylinder head, the flow characteristics of the incoming fresh gases have been optimized and the space required to install the intake pipe has been significantly reduced. Mounting for the new HDE 6 injectors, were specially adapted to the cylinder head of the N63TU3 engine. The cylinder heads for the N63B44M3 engine and N63B44T3 engine are identical.

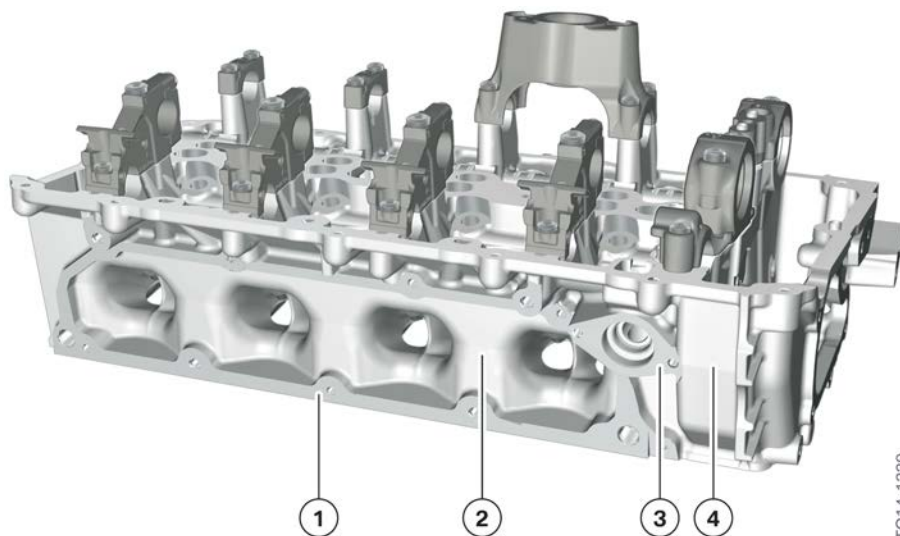

N63TU3 engine, cylinder head

N63TU3 Engine

2. Engine Mechanical

Index	Explanation
1	Sealing flange for intake system
2	Partially integrated intake pipe
3	Flange for Valvetronic servomotor
4	Cylinder head, cylinder bank 1

A different material is used in the valve stem seal of the N63TU3 engine to prevent it from hardening prematurely.

3rd generation Valvetronic technology is also used in the N63TU3 engine, as is already the case in the N55 and N63TU2 engines. The Valvetronic servomotor is connected on the outer side at the cylinder head.



The combination of exhaust turbocharger, Valvetronic and direct fuel injection is known as **Turbo Valvetronic Direct Injection (TVDI)**.

2.1.4. Cylinder head cover

Design

The cylinder head cover in the N63TU3 engine is based on the same concept as the N63TU2 engine. The cylinder head cover of the N63B44M3 engine was taken over from the N63TU2 engine.

The cylinder head cover of cylinder bank 1 with mounting for the crankcase pressure sensor and mountings for the ignition coils in the N63B44T3 engine has been adapted and also features additional mountings for the holder of the vehicle wiring harness. The cylinder head cover of cylinder bank 2 of the N63B44T3 engine originates from the S63B44T4 engine.

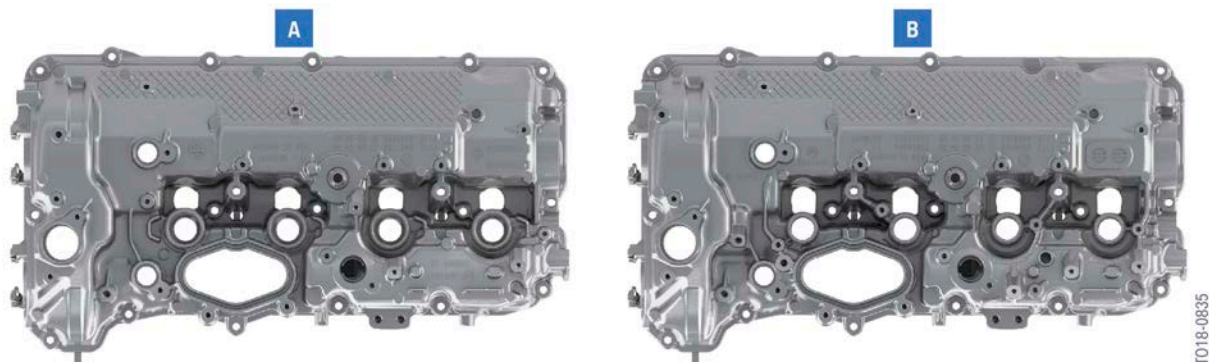

N63TU3 engine, comparison of cylinder head covers

Index	Explanation
A	N63B44M3 engine (identical to N63TU2 engine)
B	N63B44T3 engine

N63TU3 Engine

2. Engine Mechanical

2.2. Crankshaft

Compared with the N63TU2 engine, only minor modifications have been made to the crankshaft.

The bearing shells of the N63B44T3 engine have been replaced. A new material composition is used for the main bearing shell. IROX-coated bearing shells are used for the main bearing cap. A new approach has been adopted for balancing the crankshaft of the N63B44T3 engine.



N63TU3 engine, crankshaft drive with connecting rod and piston

Index	Explanation
1	Crankshaft
2	Sprocket for oil pump
3	Sprocket for camshafts

N63TU3 Engine

2. Engine Mechanical

2.2.1. Connecting rod with bearing

- The connecting rod of the N63B44M3 engine has been taken over from the S63B44T2 engine
- The connecting rod on the N63B44T3 engine has been taken from the S63B44T4 engine.

It is a cracked forged connecting rod with even pitch. The small connecting rod eye is drilled into the forged, trapezoidal connecting rod head, undergoes precise surface treatment, is hardened and therefore has no bush. The force acting from the piston via the wrist pin is optimally distributed to the bushing surface by this shaped bore and the edge load.



TO14-1340

N63TU3 engine, cracked connecting rod with even pitch

N63TU3 Engine

2. Engine Mechanical

2.2.2. Piston with piston rings

The pistons of the N63B44M3 engine have been carried over from the N63TU2 engine.

Newly developed cast pistons with a press-formed graphite coating on the piston skirt are used in the N63B44T3 engine. This is necessary because the cylinder walls are electric arc wire sprayed and the pistons were therefore adapted at the same time.

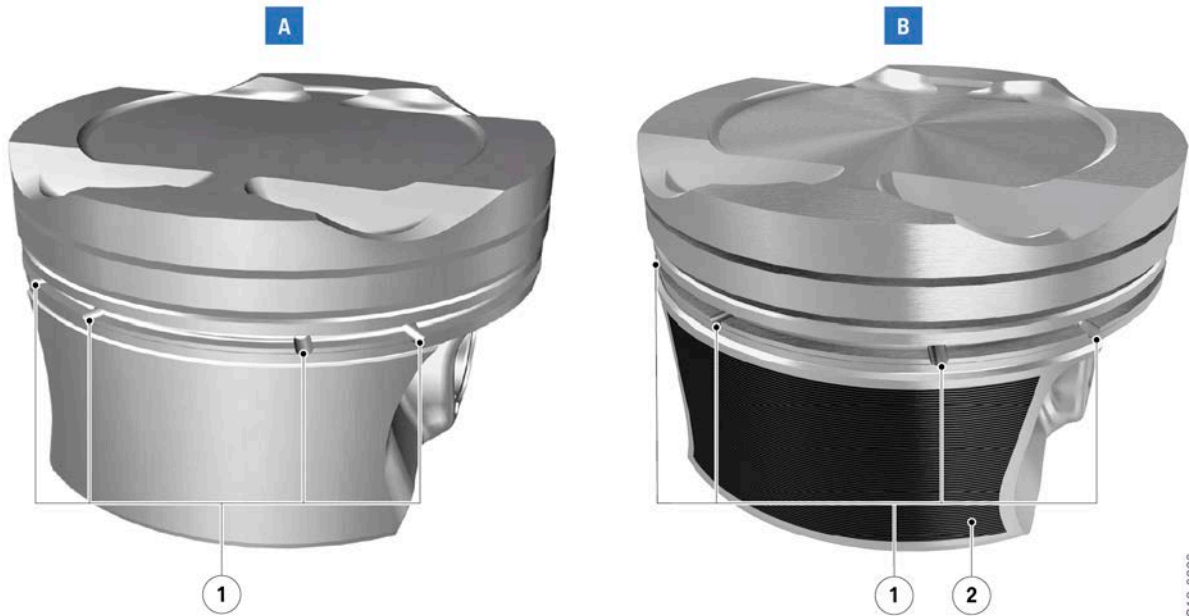

N63TU3 engine, piston comparison

T018-0836

Index	Explanation
A	N63B44M3 engine, piston
B	N63B44T3 engine, piston
1	8 oil drains
2	Graphite coating on piston skirt

Together with the 8 oil drains in the piston skirt, the additional oil groove facilitates the drainage of the oil pushed down by the oil scraper ring when the piston moves down. This prevents the oil from being carried past the piston rings, in particular when the engine is in coasting overrun mode (during which a vacuum is generated in the combustion chamber).

In terms of the piston rings, the ring package from Mahle has been carried over from the N63TU2 engine. Only the oil scraper ring in the N63TU3 engine has been replaced by a U-Flex ring.

N63TU3 Engine

2. Engine Mechanical

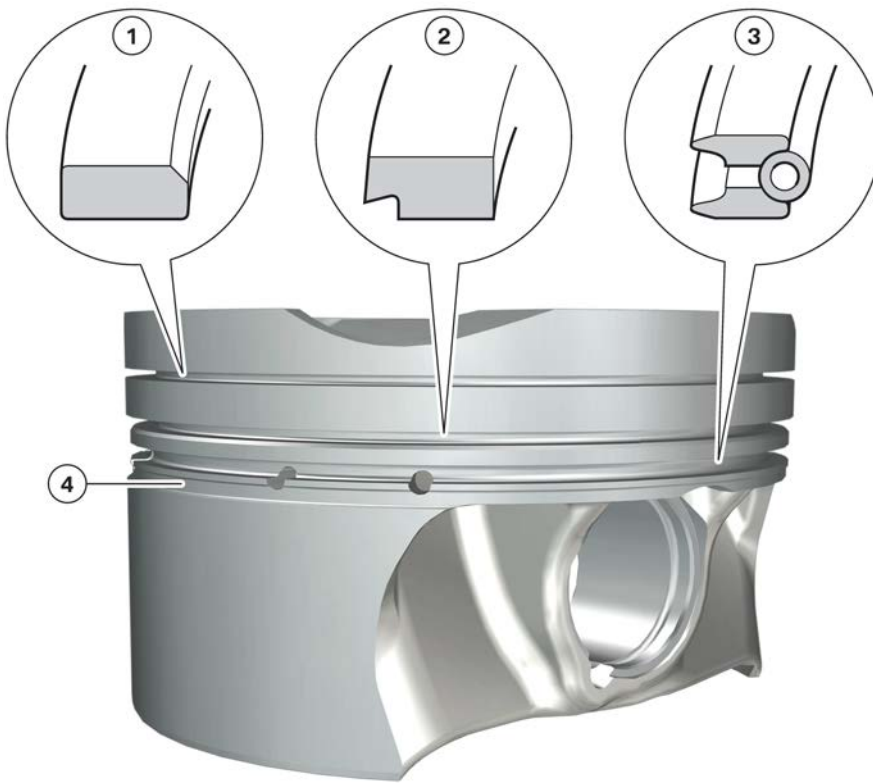

TO14-1342

N63TU3 engine, cast pistons with piston rings

Index	Explanation
1	Plain rectangular compression ring with ball-shaped tire tread (B-ring)
2	Taper faced piston ring (NM-ring)
3	U-ring with spiral expander (U-Flex ring)
4	Additional oil groove

N63TU3 Engine

2. Engine Mechanical

2.3. Camshaft drive/chain drive

The chain drive for the camshafts in the N63TU3 engine has been carried over from the N63TU2 engine.

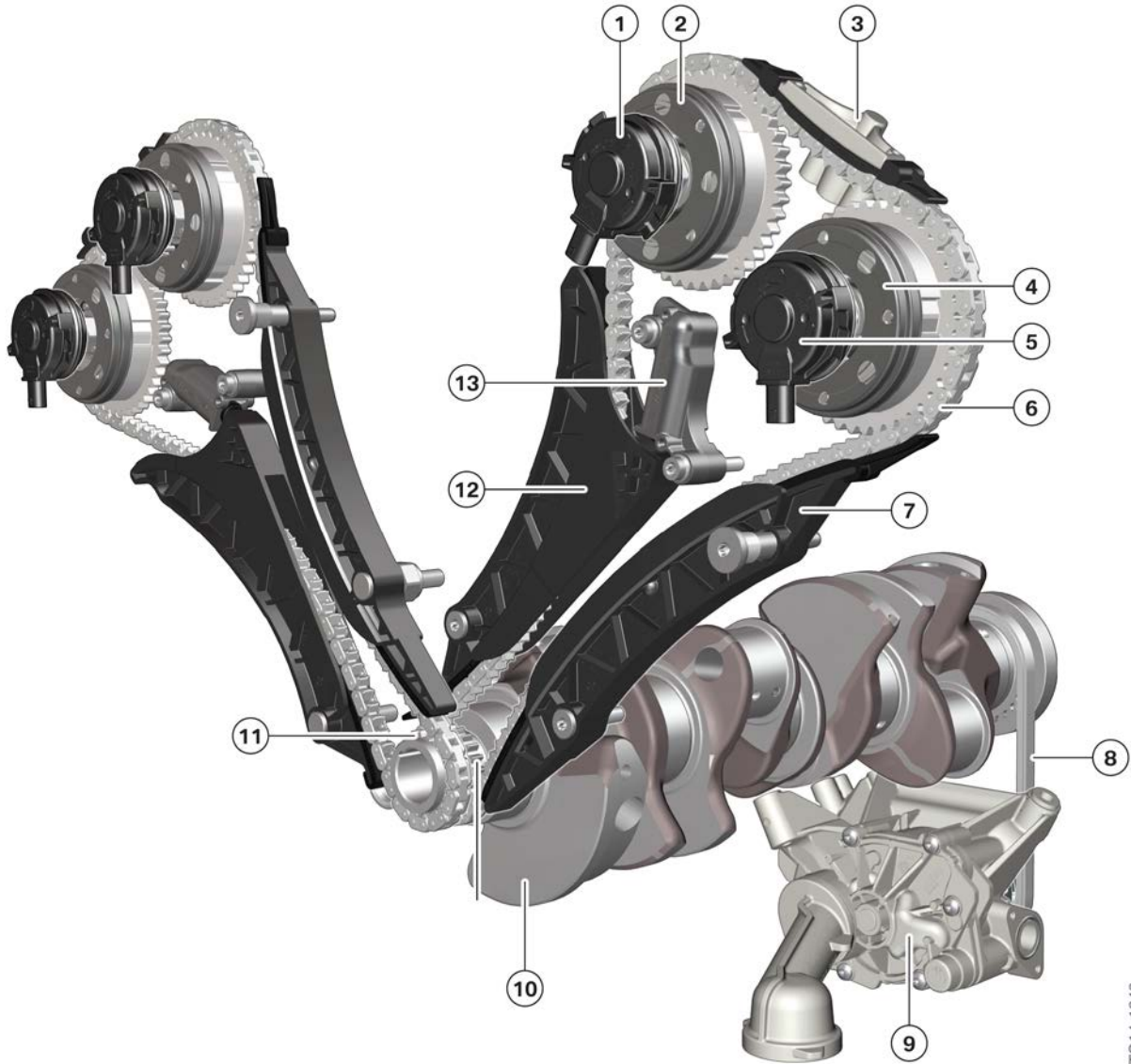

TO14-1343

N63TU3 engine, chain drive

Index	Explanation
1	VANOS solenoid actuator, exhaust side
2	VANOS unit, exhaust side
3	Slide rail with oil supply
4	VANOS unit, intake side
5	VANOS solenoid actuator, intake side

N63TU3 Engine

2. Engine Mechanical

Index	Explanation
6	Sleeve-type chain for camshaft drive
7	Slide rail
8	Sleeve-type chain for oil pump drive
9	Characteristic map-controlled oil pump
10	Crankshaft
11	Crankshaft gear
12	Tensioning rail
13	Chain tensioner

The timing chain pins have been reworked. To reduce wear, the pins have been recoated with chromium nitride (CrN).

N63TU3 Engine

3. Oil Supply

The oil supply of the N63TU3 engine is the same as the oil supply of the N63TU2 engine.

A new oil pressure sensor is used which provides a more precise sensor signal in the N63TU3 engine.

N63TU3 Engine

4. Intake and Exhaust System

The following changes have been made to the intake air and exhaust emission system in the N63TU3 engine:

- Hot film air mass meter is no longer used.
- Twin-scroll exhaust turbocharger technology with electrical wastegate valve controller and Overboost function in the N63B44M3 engine.
- Twin-scroll exhaust turbocharger technology with electrical wastegate valve controller and electrical blow-off valves in the N63B44T3 engine.

4.1. Air mass determination

The air mass drawn into the N63TU3 engine is not measured directly by a hot film air mass meter and is instead calculated in the Digital Motor Electronics. The Digital Motor Electronics is therefore programmed to calculate the filling based on empirical values (filling model). The following signals are applied to this calculation.

Signals:

- VANOS setting, valve lift setting (load sensing)
- Throttle valve position (throttling)
- Intake air temperature (air density correction)
- Engine temperature (air density correction)
- Engine speed (cylinder charging)
- Intake manifold differential pressure (throttling correction)
- Ambient pressure (air density based on altitude correction)

The air mass calculated in this way is adjusted and corrected if necessary in line with the oxygen sensor signals (air/fuel ratio) and the injection period (fuel quantity). If the oxygen sensors fail, a fault memory entry is made in the Digital Motor Electronics (air mass plausibility). Adjustment to the calculated air mass does not apply in this case.

The legally required monitoring of the crankcase ventilation for leakage in US versions is achieved in the N63TU3 engine via the crankcase pressure sensor. For this reason, the hot film air mass meter could also be deleted in the US version..

4.2. Intake air monitoring

An additional intake air temperature sensor is used in the N63B44T3 engine in the clean air line of cylinder bank 2.

The purpose of the intake air temperature sensor is to determine the temperature of the intake air more precisely.

N63TU3 Engine

4. Intake and Exhaust System



N63TU3 engine, intake air temperature sensor

Index	Explanation
1	Intake air temperature sensor

4.3. Crankcase ventilation monitoring system

As part of the CO₂ measures, further systems are monitored for compliance with the legally required emission limits. One system which is also incorporated into the N63TU3 engine is the crankcase ventilation leakage monitoring.

A crankcase pressure sensor is used in the N63TU3 engine to detect a leakage in the crankcase ventilation and is connected to the Digital Motor Electronics 1.

N63TU3 Engine

4. Intake and Exhaust System

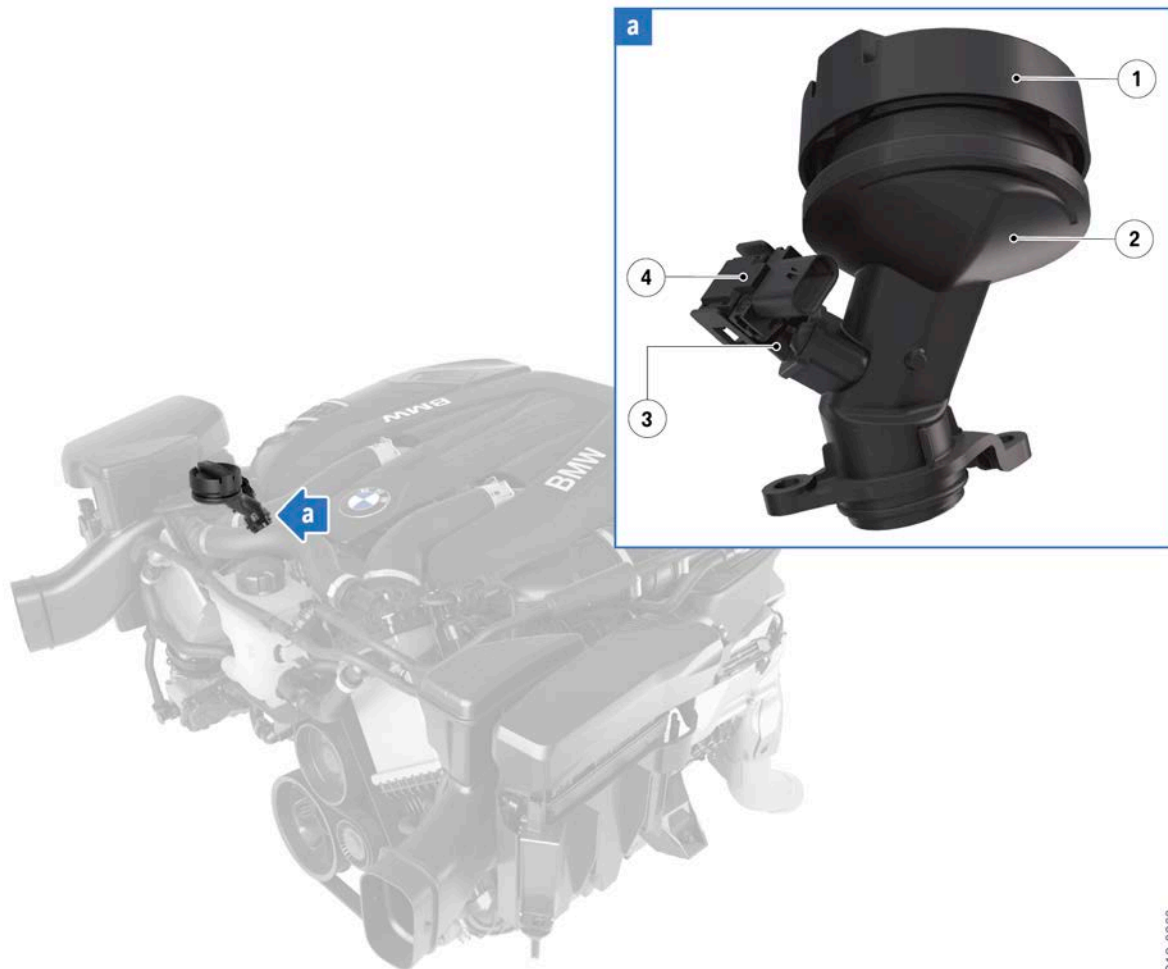

T018-0860

N63TU3 engine, N63B44M3 engine crankcase pressure sensor

Index	Explanation
a	Installation location of crankcase pressure sensor
1	Oil filler cap
2	Filler pipe
3	Sensor bracket
4	Crankcase pressure sensor

N63TU3 Engine

4. Intake and Exhaust System

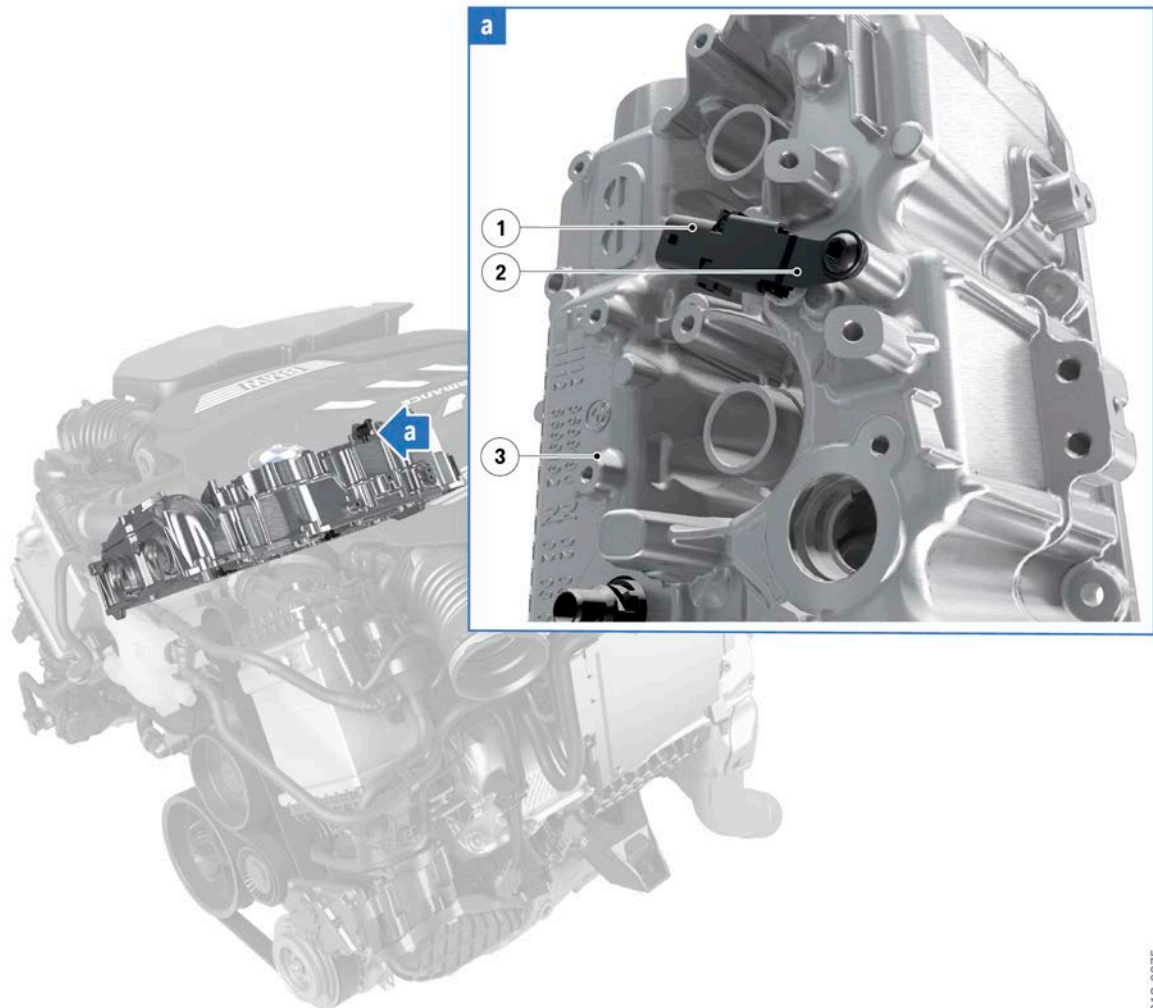

N63TU3 engine, N63B44T3 engine crankcase pressure sensor

T018-0875

Index	Explanation
1	Crankcase pressure sensor
2	Sensor bracket
3	Cylinder head cover cylinder bank 1

Blow-by gases contain multiple hydrocarbons. In the N63TU3 engine, these gases are also introduced into the combustion in a controlled manner via the intake system by existing control systems, such as the crankcase ventilation. The crankcase ventilation is monitored to ensure that if a malfunction occurs, e.g. a leakage, unburned hydrocarbons do not enter the ambient air.

N63TU3 Engine

4. Intake and Exhaust System

A leak is detected based on defined setpoint values in the characteristic map of the Digital Motor Electronics. To do so, the Digital Motor Electronics carries out the following steps:

- Measurement of the pressure in the crankcase ventilation at an engine load and speed defined in the characteristic map.
- Comparison of the actual pressure reading with the setpoint pressure value stored in the characteristic map.
- If the setpoint pressure value is exceeded, a leakage is detected.
- Output of a fault in the fault memory.

A leakage is most easily detected by the crankcase pressure sensor at a medium engine speed between 500 rpm and 3,000 rpm. The engine load for leak detection in the case of the crankcase pressure measurement is between 20% and 80% on average.

The crankcase pressure sensor is connected to the Digital Motor Electronics 1.

4.4. Exhaust turbochargers N63B44M3

The N63B44M3 engine is equipped with 2 exhaust turbochargers which have been taken over from the N63TU2 engine.

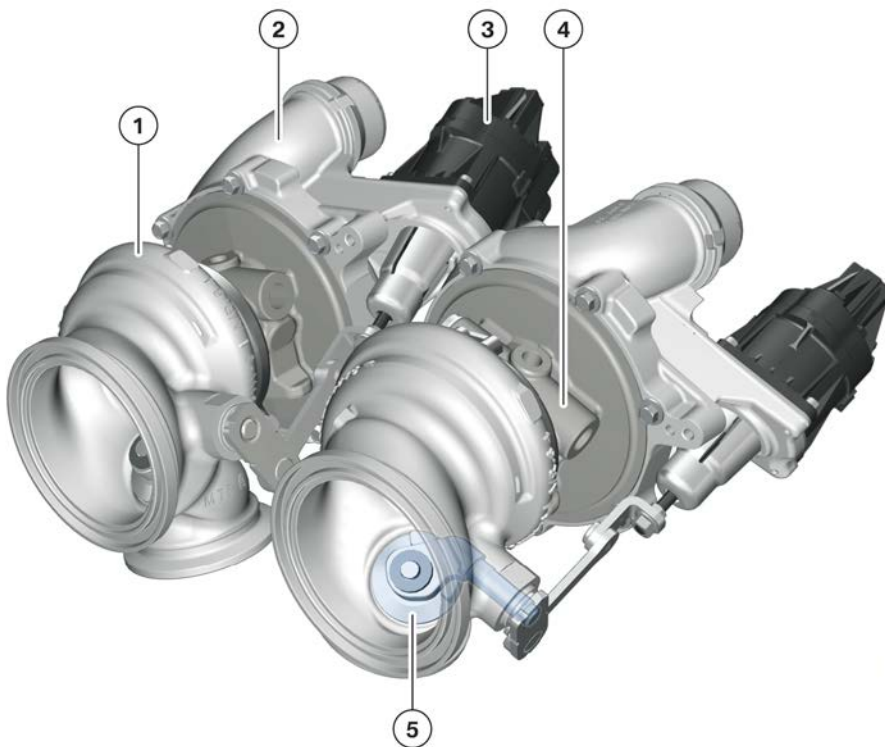

N63TU3 engine, N63B44M3 engine exhaust turbocharger

TO14-1383

N63TU3 Engine

4. Intake and Exhaust System

Index	Explanation
1	Turbine housing
2	Compressor output
3	Electric wastegate valve controller
4	Bearing housing
5	Wastegate valve

4.4.1. Overboost

In the N63B44M3 engine, the overboost feature is achieved by briefly increasing the charging pressure from 0.1 bar to above the normal charging pressure. This means that the torque of 650 Nm (479 lb-ft) is maintained up to the engine speed range of 5,000 rpm along with a slight HP increase of 34 HP for a short period of time.. The Overboost function of the N63B44M3 engine is only active in the Launch Control function.

One-piece wastegate valves are used, increasing robustness.



For assembly precise alignment of the exhaust turbocharger is necessary. Please strictly observe the repair instructions.

N63TU3 Engine

4. Intake and Exhaust System

4.5. Exhaust turbocharger in the N63B44T3 engine

The N63B44T3 engine has 2 exhaust turbochargers supplied by Honeywell.



T018-0838

N63TU3 engine, N63B44T3 engine exhaust turbocharger

Index	Explanation
1	Compressor housing
2	Turbine housing
3	Compressor output
4	Blow-off valve
5	Electric wastegate valve controller

One-piece wastegate valves are used, increasing robustness.



For assembly precise alignment of the exhaust turbocharger is necessary. Please strictly observe the repair instructions.

N63TU3 Engine

4. Intake and Exhaust System

4.5.1. Blow-off control

The blow-off valves in the N63B44T3 engine serve to reduce unwanted charging pressure peaks that can occur when the throttle valve is closed quickly. They play an important role in terms of the engine acoustics and contribute to the component protection of the exhaust turbocharger.

If the throttle valve is closed at high engine speeds, a vacuum arises in the intake pipe. Behind the compressor a high amount of ram pressure builds up, which cannot escape as the path to the intake pipe is locked. The consequence of this would be to "pump up" the charger. This means that:

- a very noticeable and annoying pump noise occurs,
- along with this pump noise, a load which has a damaging effect on the exhaust turbocharger, as high-frequency pressure waves put pressure on the bearings of the exhaust turbocharger in an axial direction.

The blow-off valves are electrically operated. If the throttle valve is closed, the charging pressure (before the throttle valve) and its increase can be compared to stored setpoint values. If the actual values are a certain value above the setpoint, the blow-off valves are opened. The charging pressure is thus directed to the intake side of the compressor. This process means that no annoying and damaging pumps arise.

4.6. Exhaust emission system

4.6.1. Exhaust manifold

The exhaust manifold of the N63TU3 engine is the same as the exhaust manifold of the N63TU2 engine.

The hose clamp for mounting the exhaust turbocharger on the exhaust manifold has been modified. In the N63TU3 engine, a high-temperature resistant V-clip from the S63B44T4 engine is used.

4.6.2. Catalytic converters

The design and function of the catalytic converters and oxygen sensors in the N63TU2 engine has also been adopted here.

4.6.3. Exhaust system

Depending on the exhaust emission standards and vehicle type, various exhaust systems and associated monitoring components are used in the N63TU3 engine.

- Front silencer
- Rear silencer
- Electrical exhaust flaps
- Exhaust tailpipes with tailpipe trims fixed to the body.

N63TU3 Engine

5. Cooling

Apart from some minor changes, the cooling system is the same as the cooling system of the N63TU2 engine. The following changes have been made to the cooling system in the N63TU3 engine:

- The mounting orientation of the cooling components has been adapted to the relevant vehicle concept.
- 1 or 2 external radiators, depending on the vehicle concept.
- Bypass line between the two indirect charge air coolers.

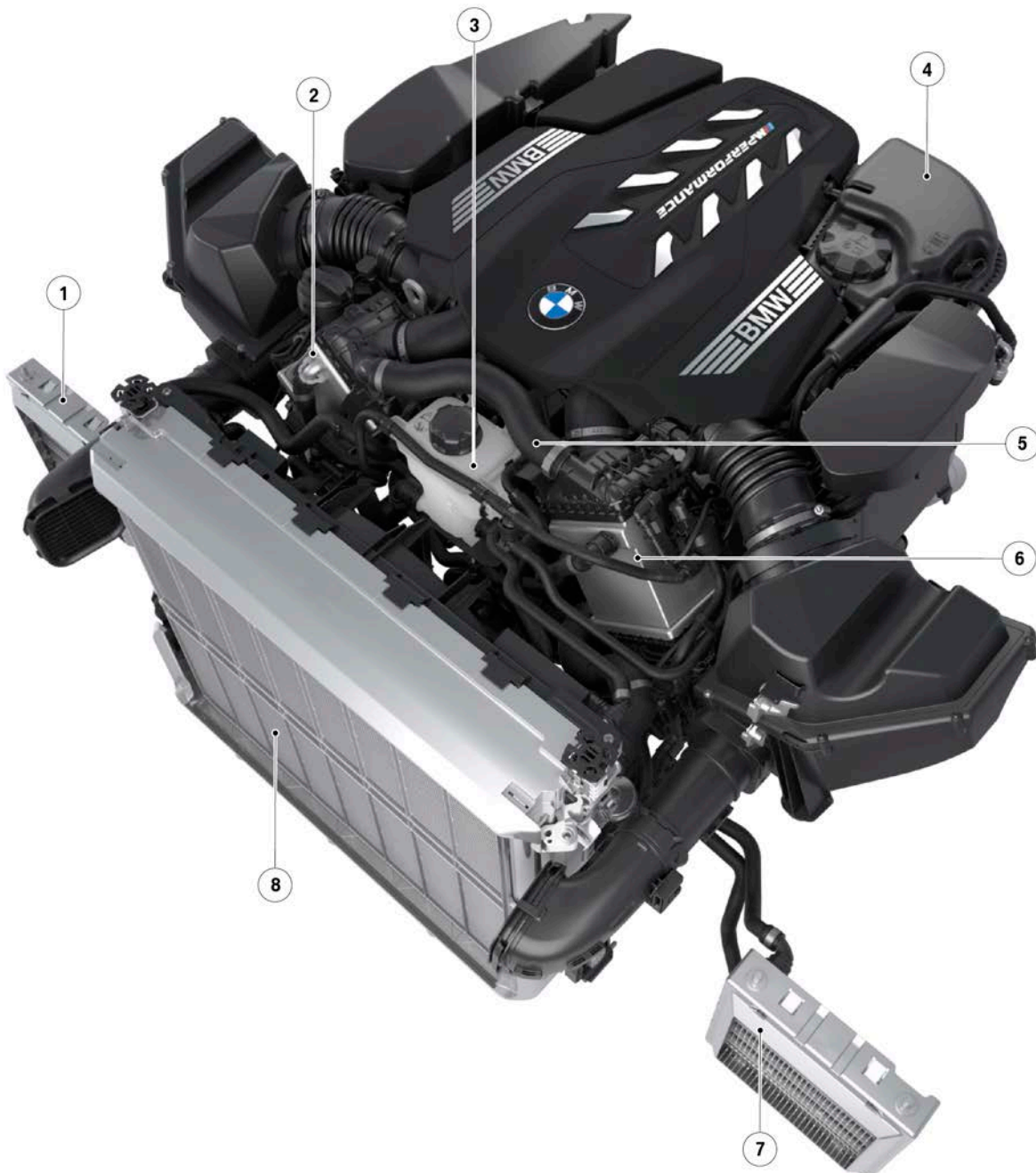

T018-0876

N63TU3 Engine

5. Cooling

Index	Explanation
1	External radiator, engine right
2	Charge air cooler, cylinder bank 1
3	Expansion tank (charge air cooling)
4	Expansion tank (engine cooling)
5	Bypass line, charge air cooler
6	Charge air cooler, cylinder bank 2
7	External radiator, engine left
8	Cooling module

5.1. Charge air cooler

There is a bypass line between the charge air cooler of cylinder bank 1 and charge air cooler of cylinder bank 2 in the N63TU3 engine. The bypass line between charge air coolers improves the gas dynamics in the intake plenums.

The connection between the two charge air coolers provides the following benefits:

- Improved throttle response
- Improved torque in lower engine speed range
- Improved acoustics.



N63TU3 engine, charge air cooler comparison

Index	Explanation
A	Charge air cooler N63TU2
B	Charge air cooler N63TU3

The system supplier of the charge air coolers is Mahle.

N63TU3 Engine

6. Fuel Preparation

For the N63TU3 engine, the high-pressure injection HDE 6 is used.

Changes were made in regard to the fuel injection pressure, which can now range up to 350 bar. Increasing the fuel injection pressure from 200 bar to 350 bar has the following advantages:

- Improved fuel atomization
- Reduced fuel wall film formation
- Shorter injection periods.

These advantages due to the fuel injection pressure increase to 350 bar led to the following improvements:

- Reduction in particle emissions
- Improved engine response under high engine load
- Improved engine response under dynamic engine operation.

6.1. Overview

The following overview shows the fuel preparation of the N63TU3 engine. It essentially corresponds to the systems with direct fuel injection familiar in BMW models. Only the routing of the fuel feed line to the high pressure pumps has been modified and adapted.

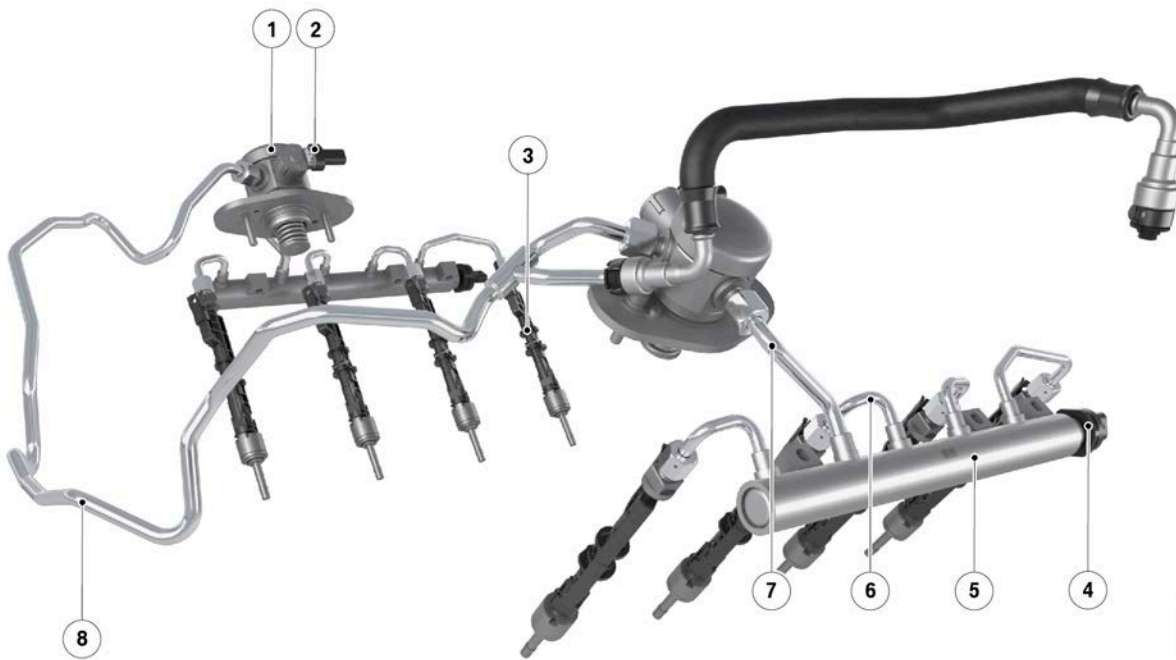

N63TU3 engine, fuel preparation

T018-0861

N63TU3 Engine

6. Fuel Preparation

Index	Explanation
1	High pressure pump
2	Fuel quantity control valve
3	Injector
4	Rail pressure sensor
5	Rail
6	High-pressure line, rail - injector
7	High-pressure line, high-pressure pump - rail
8	Fuel delivery line

6.2. Fuel pump control

The electric fuel pump delivers the fuel from the fuel tank via the feed line to the high pressure pump at a primary pressure of 5.9 bar. The on-load speed control is effected via the Digital Motor Electronics. The low-pressure sensor is dispensed with.

6.3. High pressure pump

The familiar Bosch high pressure pump 6 is used. This is a single-piston pump which is driven from the exhaust camshaft via a triple cam. So that sufficient fuel pressure is guaranteed in each load condition of the engine, a high pressure pump is used in the N63TU3 engine for each cylinder bank. In the high-pressure pump, the pump piston and plunger were modified and the materials were adjusted. Its design is already in use in the previous 4 and 8-cylinder engines.

6.4. Injectors

Bosch high-pressure fuel injection valves with the designation high-pressure fuel injection valve 6 with CVO are used. Due to the increase in fuel system pressure from 200 bar to 350 bar, the solenoid valve injectors were optimized using suitable materials and coatings.

N63TU3 Engine

6. Fuel Preparation



T018-0872

N63TU3 engine, injector



Work on the fuel system is only permitted after the engine has cooled down. The coolant temperature must not exceed 40 °C (°104 F). This stipulation must be observed without fail, as otherwise there is a risk of fuel being sprayed back on account of the residual pressure in the high-pressure fuel system.

When working on the high-pressure fuel system, it is essential to adhere to conditions of absolute cleanliness and to observe the work sequences described in the repair instructions. Even the slightest contamination and damage to the screwed fittings of the high-pressure lines can cause leaks.

When working on the fuel system of the N63TU3 engine, it is important to ensure that the ignition coils are not fouled with fuel. The resistance of the silicone material is greatly reduced by sustained contact with fuel. This may result in flashovers on the spark plug head and thus in misfires.

- Before making any modifications to the fuel system, without fail remove the ignition coils and protect the spark plug shaft against ingress of fuel by covering with a cloth.
- Prior to a new installation of the solenoid valve injectors, the ignition coils must be disassembled and the highest possible level of hygiene ensured.
- Ignition coils heavily fouled by fuel must be replaced.

N63TU3 Engine

6. Fuel Preparation

- The CV-O function comprises the system components "Injector" and "Digital Motor Electronics" (DME). These components therefore have to be identified with the vehicle identification number in the Electronic Parts Catalog (EPC) when they are replaced.
 - Where injectors and DME support the CVO function, the injection quantity compensation during the replacement of one of the components is omitted.
 - An excessive rotational angle at the injector shank, and excessive tensile and compression forces during removal and installation can lead to damage and therefore leaks in the fuel system.
 - The stems of the solenoid valve injectors can only withstand a certain tensile force and a certain torque. When removing and installing the injectors it is essential to follow the specific procedure set out in the repair instructions, as otherwise the injectors may be damaged.
 - Due to the design, dirt particles, grains of sand, etc. may enter the shafts of the injectors and spark plugs during operation, particularly in dusty environments with poor road surfaces. Before disassembly, always blow out the shafts with a sharp jet of compressed air from all possible positions and angles using a lance that is as long as possible. Once the injector or spark plug has been removed, any particles should also be cleared from the edge of the bore hole.
 - For any service work required, the current information and specifications in the documents in the Integrated Service Technical Application (ISTA) must be observed in each case.
-

N63TU3 Engine

7. Engine Electrical System

7.1. Engine control unit

A new generation of Bosch engine control units is used in the N63TU3 engine. 8th-generation engine electronics (DME) features a common control unit platform for Gasoline and diesel engines that is already used with modular engines. Its appearance is characterized by a uniform housing and a uniform connector strip. However, the hardware inside has been adapted to the various applications.

The control unit code (DME 8.8T.0) can be decoded as follows:

Abbreviation	Meaning
DME	Digital Motor Electronics
8	Control unit generation (modular operating system for Gasoline and diesel engine)
8	Number of cylinders as hexadecimal figure
T	Technical update
0	Vehicle electrical system architecture

Number of cylinders as a hexadecimal figure:

- 3 = 3-cylinder engine
- 4 = 4-cylinder engine
- 6 = 6-cylinder engine
- 8 = 8-cylinder engine
- C = 12-cylinder engine.

Hardware variant:

- T = TÛ1 technical update 1

Vehicle electrical system architecture:

- 0 = variant electrical system 2015
- 1 = variant electrical system 2018

Examples for Gasoline engines:

- DME 8.4.0H = B48 PHEV* (variant electrical system 1)
- DME 8.6.1 = B58 (variant electrical system 2)
- DME 8.8.0 = N63TU2 (variant electrical system 1)
- DME 8.8T.0 = N63TU3 (variant electrical system 1)
- DME 8.C0 = N74TU (variant electrical system 1).

*PHEV = Plug-in Hybrid Electric Vehicle.

N63TU3 Engine

7. Engine Electrical System

The N63TU3 engine is therefore equipped with a Digital Motor Electronics by Bosch with the designation DME 8.8T.0. There is a separate engine control unit fixed to the vehicle for every cylinder bank. The actuators and sensors of cylinder bank 1 are assigned to the DME 1 control unit; accordingly, the DME 2 control unit is responsible for the functions of cylinder bank 2. DME 1 is the primary control unit and also accepts all information concerning the entire engine and makes it available to the DME 2 control unit either directly or via the bus system. Due to the variety of sensors and actuators it was deemed necessary to use 2 control units.

7.1.1. DME 1 control unit

The following system wiring diagram refers to the N63B44T3 engine.

N63TU3 Engine

7. Engine Electrical System

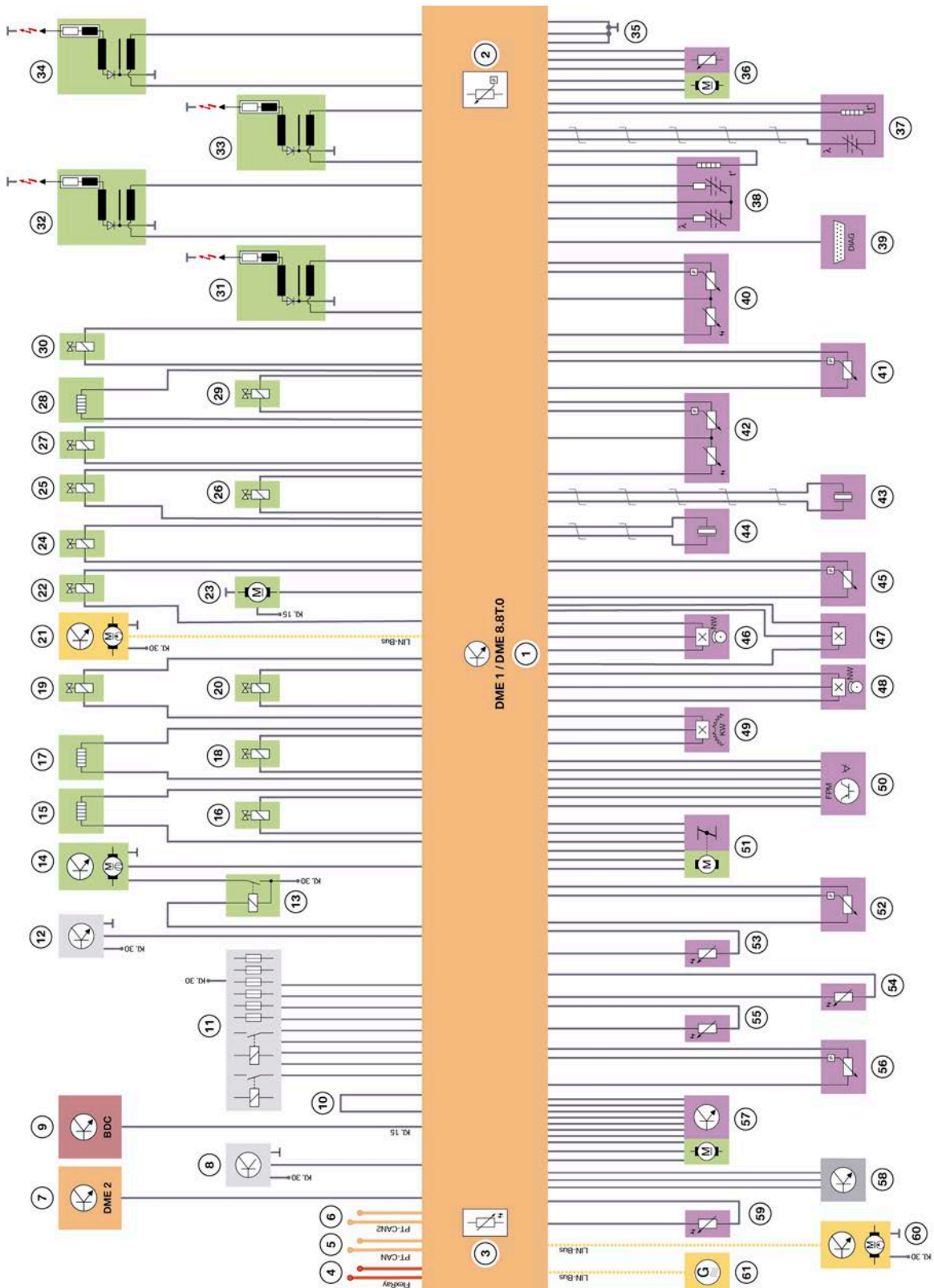

N63TU3 engine, DME 8.8T.0 DME 1

N63TU3 Engine

7. Engine Electrical System

Index	Explanation
1	Digital Motor Electronics DME 1 8.8T.0
2	Ambient pressure sensor
3	Temperature sensor
4	FlexRay
5	PT-CAN
6	PT-CAN2
7	DME 2 connection
8	Tank leak diagnosis, Natural Vacuum Leak Detection (NVLD)
9	Body Domain Controller (BDC)
10	Coupler CAN
11	Power distribution box (symbolic)
12	Fuel pump control electronics (FPC)
13	Relay for electric fan
14	Electric fan
15	Electrical heating element of thermal actuator - coolant pump
16	Map-controlled valve, oil pump
17	Data-map thermostat
18	Tank vent valve
19	VANOS solenoid valve, intake camshaft
20	VANOS solenoid valve, exhaust camshaft
21	Electric coolant pump, exhaust turbocharger
22	Blow-off valve
23	Electrical exhaust flap controller (EAKS)
24–27	Injectors
28	Fuel quantity control valve
29	Blow-off valve
30	Shutoff valve, heating
31–34	Ignition coils
35	Earth
36	Electric wastegate valve controller
37	Oxygen sensor LSF Xfour
38	Oxygen sensor LSU 5.2
39	Diagnostic connector
40	Charge air temperature and charging pressure sensor upstream of throttle valve

N63TU3 Engine

7. Engine Electrical System

Index	Explanation
41	Rail pressure sensor
42	Charge air temperature and intake-manifold pressure sensor after throttle valve
43	Knock sensors cylinder 1-2
44	Knock sensors cylinder 3-4
45	Crankcase pressure sensor
46	Camshaft sensor, intake camshaft
47	Travel sensor for thermostat
48	Camshaft sensor, exhaust camshaft
49	Crankshaft sensor, signal is looped through to DME 2
50	Accelerator pedal module
51	Throttle valve
52	Differential pressure sensor, Gasoline particulate filter
53	Coolant temperature sensor
54	Coolant temperature sensor at radiator outlet
55	Oil temperature sensor
56	Oil pressure sensor
57	Valvetronic servomotor
58	Oil-level sensor
59	Intake air temperature sensor
60	Electric coolant pump, charge air cooler
61	Alternator

7.1.2. DME 2 control unit

The following system wiring diagram refers to the N63B44T3 engine.

N63TU3 Engine

7. Engine Electrical System

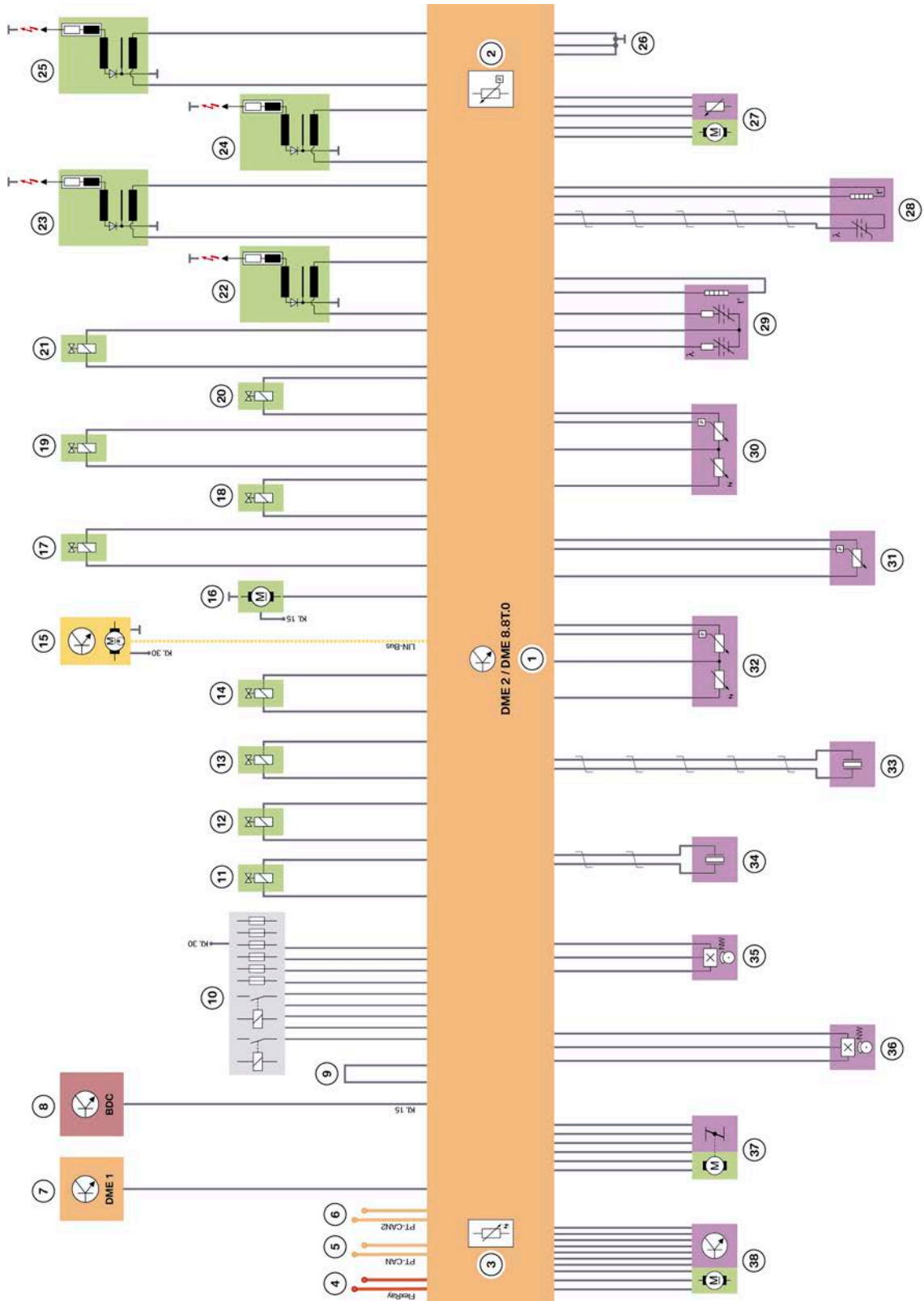

S63B44T4 engine, DME 8.8T.0 DME 2

N63TU3 Engine

7. Engine Electrical System

Index	Explanation
1	Digital Motor Electronics DME 2 8.8T.0
2	Ambient pressure sensor
3	Temperature sensor
4	FlexRay
5	PT-CAN
6	PT-CAN2
7	DME 1 connection
8	Body Domain Controller (BDC)
9	DME 1–DME 2 encoding
10	Power distribution box (symbolic)
11	VANOS solenoid valve, intake camshaft
12	VANOS solenoid valve, exhaust camshaft
13	Fuel quantity control valve
14	Tank vent valve
15	Electric coolant pump, charge air cooling
16	Electrical exhaust flap controller (EAKS)
17	Blow-off valve
18–21	Injectors
22–25	Ignition coils
26	Earth
27	Electric wastegate valve controller
28	Oxygen sensor LSF Xfour
29	Oxygen sensor LSU 5.2
30	Charge air temperature and charging pressure sensor upstream of throttle valve
31	Rail pressure sensor
32	Charge air temperature and intake-manifold pressure sensor after throttle valve
33	Knock sensors cylinder 5-6
34	Knock sensors cylinder 7-8
35	Camshaft sensor, intake camshaft
36	Camshaft sensor, exhaust camshaft
37	Throttle valve
38	Valvetronic servomotor

N63TU3 Engine

7. Engine Electrical System



Do not attempt any trial replacement of control units.

Because of the electronic immobilizer, a trial replacement of control units from other vehicles must not be attempted under any circumstances.

The connector concept is identical to that on the modular engines and features a Nano MQS connector system (Micro Quadlock System). There is a logical division into 6 modules.



Measurements on the wiring harness may only be taken using measuring procedures approved by BMW. Use of the incorrect tools, such as measuring probes, can damage the plug-in contacts.

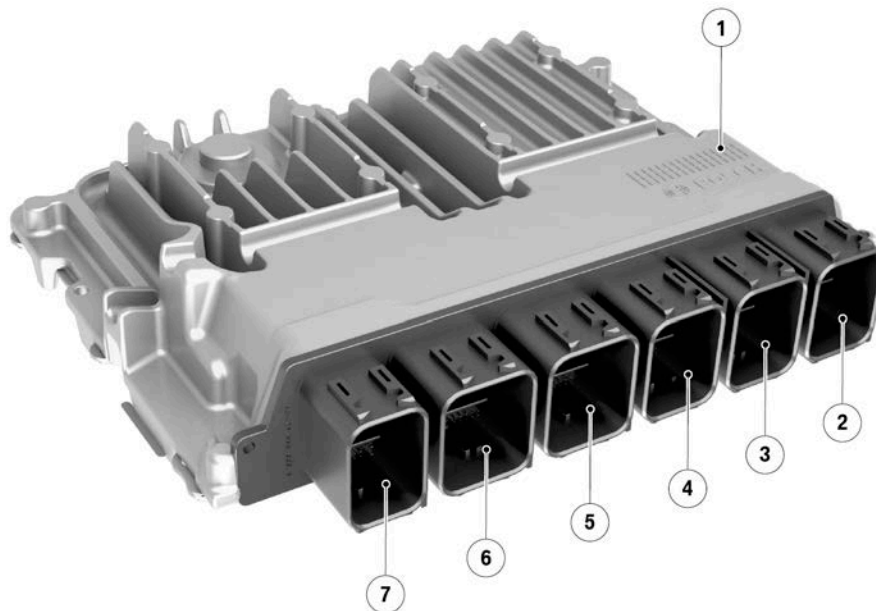

N63TU3 engine, connections DME 8.8T.0

Index	Explanation
1	Digital Motor Electronics DME 8.8T.0
2	Module 600, injection and ignition
3	Module 500, DME supply
4	Module 400, Valvetronic servomotor
5	Module 300, sensors and actuators 2
6	Module 200, sensors and actuators 1
7	Module 100, vehicle connection

N63TU3 Engine

7. Engine Electrical System

7.1.3. Overall function

The Digital Engine Electronics (DME) is the computing and switching center of the engine control system. Sensors on the engine and on the vehicle deliver the input signals. The signals for activating the actuators are calculated from the input signals, the setpoint values calculated using a computing model in the DME control unit and the stored characteristic maps. The DME control unit activates the actuators directly or via relays.

The PT-CAN wakes up the DME control unit.

The after-run begins once the terminal is switched to OFF. The adaptation values are stored during the after-run. The DME control unit uses a bus signal to signal its readiness to "go to sleep". When all the participating control units have signalled their readiness to "go to sleep", the bus master outputs a bus signal and the control units terminate communication 5 seconds later.

The printed circuit board in the DME control unit accommodates 2 sensors: a temperature sensor and an ambient pressure sensor. The temperature sensor is used to monitor the temperature of the components in the DME control unit. The ambient pressure is required for calculating the mixture composition.

7.2. Ignition coils

The N63B44M3 engine features the familiar rod-type ignition coils already used in the N63TU2 engine.

The ignition coils are used in the N63B44T3 engine in a similar manner to the modular engines.

N63TU3 Engine

7. Engine Electrical System



N63TU3 engine, ignition coils

T018-0874

Index	Explanation
A	Rod-type ignition coil N63B44M3 engine
B	Ignition coil N63B44T3 engine

- The N63B44M3 engine uses the same ignition voltage of 31 kV which is already used in the N63TU2 engine.
- The ignition voltage in the N63B44T3 engine has been increased to 42 kV.



Damage to ignition coil.

- Contamination of the silicone hose of the ignition coil must be avoided as this can lead to failure of the ignition coil.
- When working on the fuel system, cover ignition coils using suitable means, remove if necessary.
- Do not oil or grease the silicone hose of the spark plug connector. The silicone hose is coated with talc to reduce the pull-off forces.

N63TU3 Engine

7. Engine Electrical System

7.3. Spark plugs

The N63B44M3 engine features the familiar spark plugs already used in the N63TU2 engine.

New spark plugs are used in the N63B44T3 engine.



Take care when handling spark plugs.

- To avoid uncontrolled flashover of ignition sparks, make sure the insulator (ceramic) of the spark plugs is exceptionally clean.
 - The insulator of the spark plug must not be touched by fingers or labelled and must also not come into contact with liquid media such as fuel or oil.
 - Spark plugs must only be held by the spark plug thread. Threading in the spark plugs using a clean hose (fitting aid SWZ 12 1 230) is permitted.
-

N63TU3 Engine

8. Engine Cover

Two different engine covers are used in the N36TU3 engine.

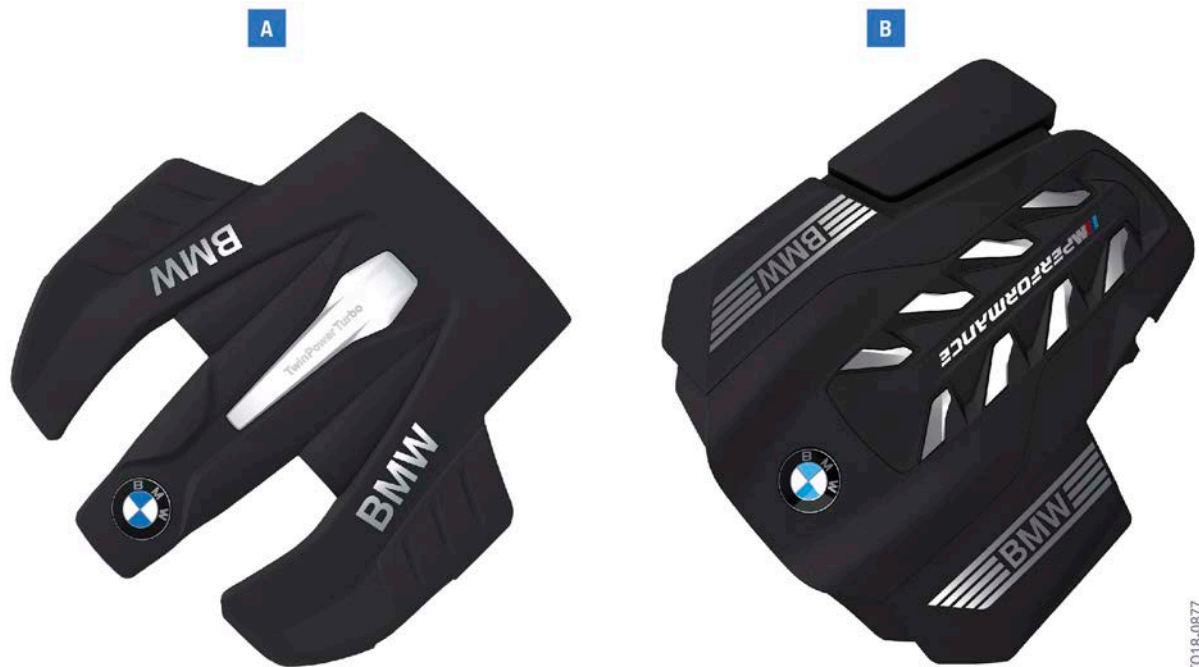

N63TU3 engine, engine cover

Index	Explanation
A	Engine cover, N63B44M3 engine
B	Engine cover, N63B44T3 engine



Damage to acoustic cover.

- Sudden pulling/tearing movements during disassembly and also application of high forces during installation may cause the acoustic cover to fracture.
- Remove/refit the acoustic cover carefully.
- Remove/refit snap-lock couplings on the ball studs one by one.
- Only remove/refit the acoustic cover at temperatures >20 °C (68 °F).
- Only use distilled water during the installation, no lubricating materials.

T018-0877

