

# Reference Manual



## B58TU ENGINE



## Technical Training

The information contained in this manual is not to be resold, bartered, copied or transferred without the express written consent of BMW of North America, LLC ("BMW NA").

Copyright © 2018 BMW of North America, LLC

**Technical training.**  
Product information.

## **B58TU Engine**



**BMW Service**

Edited for the U.S. market by:

**BMW Group University**  
**Technical Training**

ST1853

10/1/2018

## General information

### Symbols used

The following symbol is used in this document to facilitate better comprehension or to draw attention to very important information:



---

Contains important safety information and information that needs to be observed strictly in order to guarantee the smooth operation of the system.

---

### Information status: July 2018

BMW Group vehicles meet the requirements of the highest safety and quality standards. Changes in requirements for environmental protection, customer benefits and design render necessary continuous development of systems and components. Consequently, there may be discrepancies between the contents of this document and the vehicles available in the training course.

The information contained in the training course materials is solely intended for participants in this training course conducted by BMW Group Technical Training Centers, or BMW Group Contract Training Facilities.

This training manual or any attached publication is not intended to be a complete and all inclusive source for repair and maintenance data. It is only part of a training information system designed to assure that uniform procedures and information are presented to all participants.

For changes/additions to the technical data, repair procedures, please refer to the current information issued by BMW of North America, LLC, Technical Service Department.

This information is available by accessing TIS at [www.bmwcenternet.com](http://www.bmwcenternet.com).

### Additional sources of information

Further information on the individual topics can be found in the following:

- Owner's Handbook
- Integrated Service Technical Application
- Aftersales Information Research (AIR)

**The information contained in this manual is not to be resold, bartered, copied, or transferred without the express written consent of BMW of North America, LLC (“BMW NA”).**

©2018 BMW of North America, LLC

The BMW name and logo are registered trademarks. All rights reserved.

# B58TU Engine

## Contents

<b>1.</b>	<b>Introduction</b> .....	<b>1</b>
1.1.	Innovations.....	2
1.2.	Technical data.....	3
1.2.1.	Performance diagrams.....	4
1.2.2.	Model overview.....	4
<b>2.</b>	<b>Engine Mechanical</b> .....	<b>5</b>
2.1.	Engine housing.....	5
2.1.1.	Cylinder head.....	5
2.1.2.	Crankcase.....	6
2.2.	Crankshaft drive.....	7
2.2.1.	Chain drive.....	7
2.3.	Valve gear.....	10
2.3.1.	VANOS.....	10
<b>3.</b>	<b>Vacuum Supply</b> .....	<b>12</b>
3.1.	Vacuum pump.....	12
<b>4.</b>	<b>Cooling System</b> .....	<b>13</b>
4.1.	Split cooling.....	13
4.1.1.	Split cooling valve.....	16
4.1.2.	Switching logic of split cooling valve.....	17
4.2.	Heat management module.....	18
4.3.	Operating strategy of the heat management module.....	20
4.3.1.	Cold-start phase.....	21
4.3.2.	Warm-up phase.....	22
4.3.3.	Operating temperature.....	23
4.3.4.	Maximum cooling requirement.....	24
4.4.	Coolant pump.....	25
<b>5.</b>	<b>Intake Air and Exhaust System</b> .....	<b>26</b>
5.1.	Crankcase monitoring .....	26
5.1.1.	On-board diagnosis.....	26
5.2.	Exhaust turbocharger.....	27
5.2.1.	B58TU exhaust turbocharger.....	27
<b>6.</b>	<b>Fuel System</b> .....	<b>28</b>
6.1.	Fuel preparation.....	28
6.1.1.	Direct rail.....	29
6.1.2.	Solenoid valve injector.....	30
<b>7.</b>	<b>Engine Electrical System</b> .....	<b>33</b>

# B58TU Engine

## Contents

7.1.	Digital Motor Electronics (DME).....	33
7.2.	Component temperature sensor.....	34

# **B58TU Engine**

## **1. Introduction**

The product information "B58 Engine" serves as the basis for this document. This document exclusively describes the changes to the B58 engine and serves to support Technical Service. Due to the huge similarities, the two engines are described in the one document.

# B58TU Engine

## 1. Introduction

### 1.1. Innovations

To meet the legal requirements for emissions, a number of technical improvements have been implemented. The technical updates for the B58TU engine include the following new features:



New features on the B58TU engine

T018-0296

# B58TU Engine

## 1. Introduction

Index	Explanation
A	Fuel preparation with 350 bar injection pressure
B	Cylinder head with integrated exhaust manifold
C	Adapted exhaust turbocharger made from steel
D	Split cooling
E	Coolant pump with integrated pressure relief valve
F	Heat management module with electric split cooling valve
G	Single-part chain drive

Weight savings in the crankshaft drive area, injection pressure boosting in the fuel preparation area, and function changes in the engine cooling area have made it possible to reduce the CO<sub>2</sub> emissions by 2.5%, while increasing engine performance by 10 kW/50 Nm. (13 hp/36 lb-ft)

### 1.2. Technical data

The following engine versions are described in this product information:

	<b>B58B30M1</b>
Output in [kW/(hp)] at [rpm]	250 (335) 5500 - 6500
Torque in [Nm/(lb-ft)] at [rpm]	450 (330) 1500 - 5200
Displacement in [cm <sup>3</sup> ]	2998
Bore hole / Stroke in [mm]	82/94.6
Compression ratio	11.0 : 1
Combustion process	Turbo-Valvetronic direct injection
Maximum rotational speed	6500
Short-term overspeed (overboost) 15 s	7000
Idle speed	660
Permissible fuel range	ROZ 87-98

# B58TU Engine

## 1. Introduction

### 1.2.1. Performance diagrams

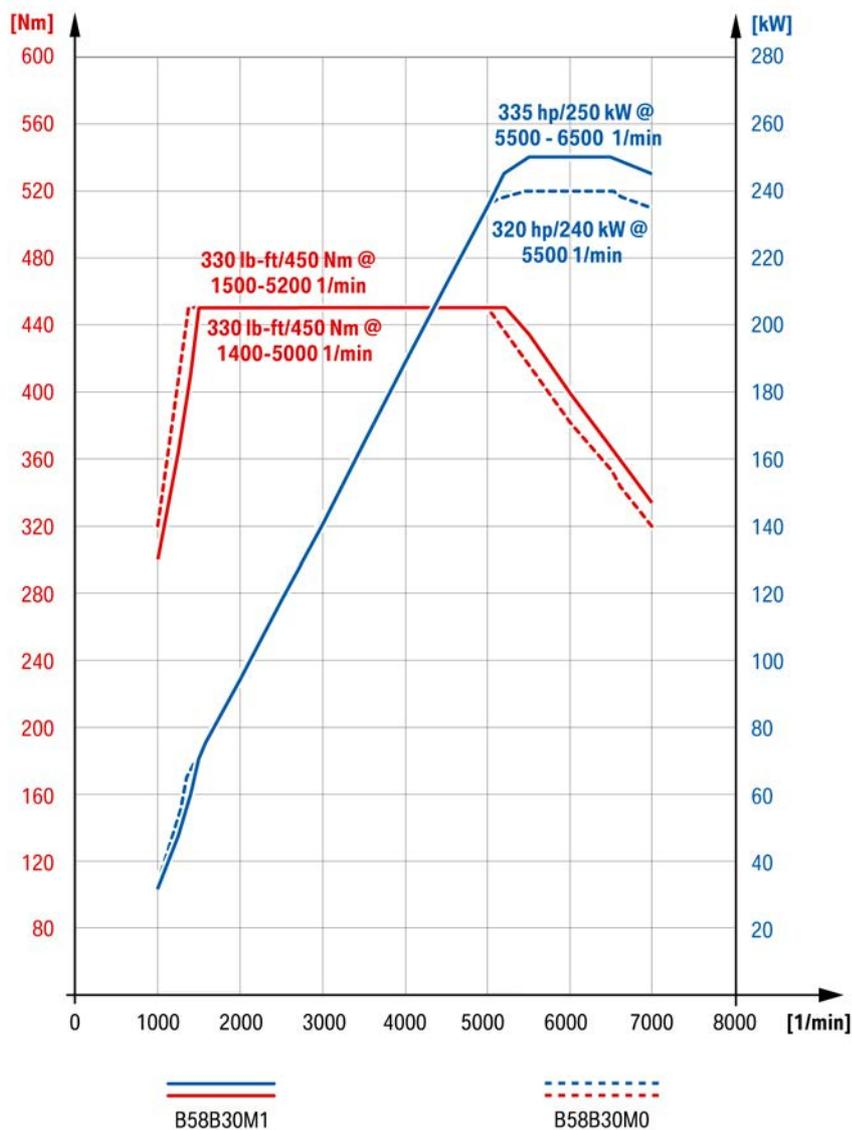

Comparison of performance curves between B58B30M1 and B58B30M0 engine

### 1.2.2. Model overview

The following table provides an overview of the models in which the new B58TU engine is used from 07/2018:

Model	Engine
BMW X5 xDrive40i (G05), from 07/2018	B58B30M1
BMW X7 xDrive40i (G07), from 12/2018	B58B30M1

# B58TU Engine

## 2. Engine Mechanical

### 2.1. Engine housing

#### 2.1.1. Cylinder head

The following figures show the two cylinder head variants with and without the cylinder head-integrated exhaust manifold.

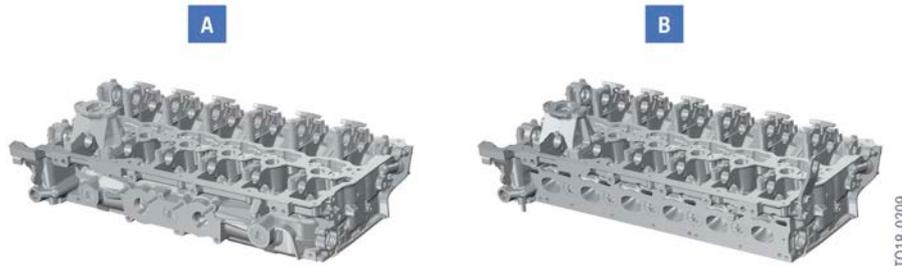

Cylinder head of B58TU engine

Index	Explanation
A	Cylinder head with integrated exhaust manifold ZIAK <sup>1</sup>
B	Cylinder head without integrated exhaust manifold nZIAK <sup>2</sup>

ZIAK<sup>1</sup> = cylinder head-integrated exhaust manifold

nZIAK<sup>2</sup> = non cylinder head-integrated exhaust manifold

With the gravity casting process the aluminum alloy is embedded into a prefabricated mould of steel and sand using gravity. The result is a cylinder head made from aluminum gravity die casting AlSi7MgCu0.5 T5.

The cylinder head of the B58TU engine in the medium power level is a new design. The exhaust manifold was integrated in the housing of the cylinder head. Depending on the engine output, the engine weight, the operating strategy of the engine and the cooling surfaces, the exhaust manifold is integrated in the cylinder head housing and the exhaust turbocharger is interlocked at the cylinder head.

Owing to the higher mechanical and thermal loads, gasoline engines in the upper power levels and higher have a traditional cylinder head **without** the exhaust manifold integrated in the cylinder head.

The following benefits could be achieved with the integration of the exhaust manifold in the cylinder head housing:

- Benefits in fuel consumption and pollutant emissions due to faster warm-up of the engine.
- Weight reduction with the use of aluminum instead of steel.
- Cost reduction by eliminating the need for a separate exhaust manifold.
- Simple disassembly and installation both of the cylinder head and the exhaust turbocharger.

The following table provides an overview of the engine versions that use a cylinder head with an integrated exhaust manifold:

# B58TU Engine

## 2. Engine Mechanical

### B58TU Engine

Engine version	3.0 l	3.0 l
Power level	Medium power level	Upper power level
Cylinder head	Cylinder head-integrated exhaust manifold ZIAK	Non cylinder head-integrated exhaust manifold nZIAK

### 2.1.2. Crankcase

#### Honing process

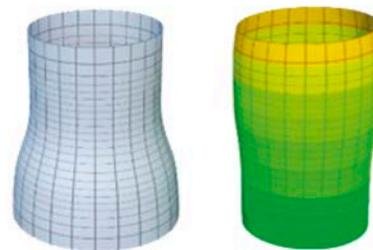
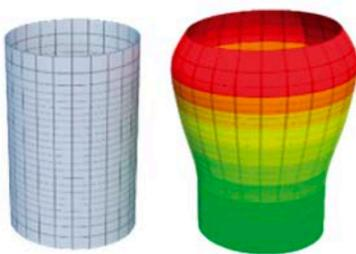
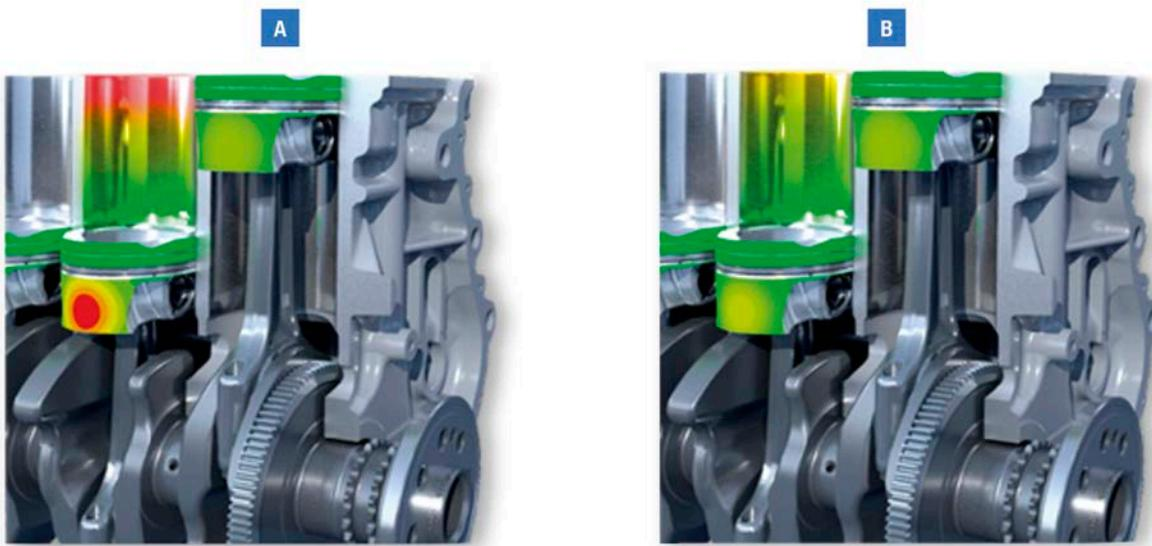

T018-0603

Honing process "old/new"

Index	Explanation
A	Previous manufacturing process of internal cylindrical honing
B	New manufacturing process of form honing

# B58TU Engine

## 2. Engine Mechanical

The cylindrical bore hole of a combustion engine becomes deformed during the operating condition by thermal loads. Form honing allows this deformation to be achieved in production, so that there is an almost cylindrical shape in the operating condition. This has a positive effect on the emissions quality, oil and fuel consumption, as well as output and wear.

### 2.2. Crankshaft drive

#### 2.2.1. Chain drive

**Features:**

- Chain drive at the side of the engine emitting the forces
- Single-part chain drive for driving the camshafts
- Single sleeve-type chain 8 mm
- Electric motor of the combined oil-vacuum pump via a separate chain
- Plastic tensioning and guide rail
- Hydraulic chain tensioner with spring preload and sealing sleeve.

# B58TU Engine

## 2. Engine Mechanical

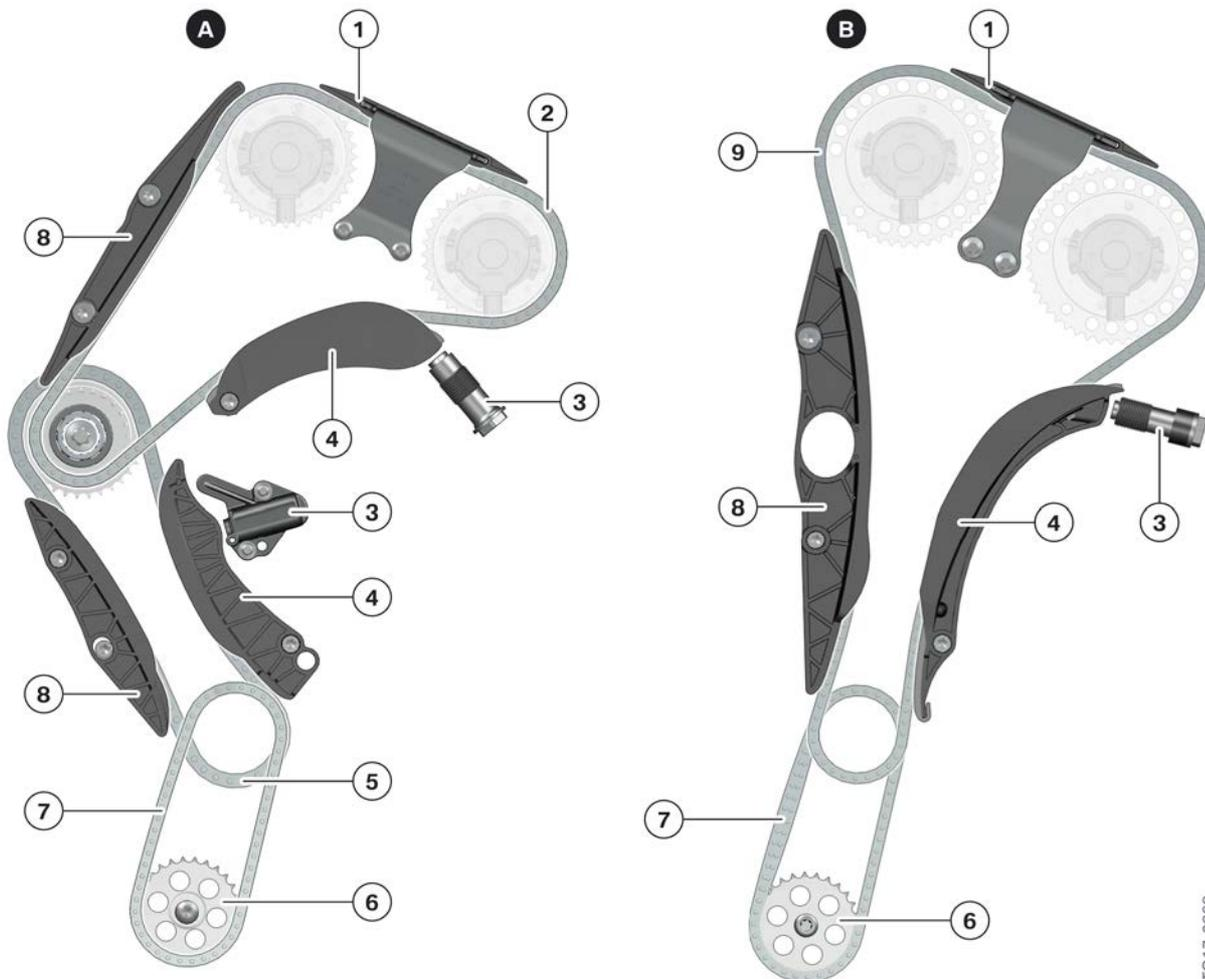

TO17-0369

Comparison of the chain drive of B58 engine and B58TU engine

Index	Explanation
A	Two-part chain drive
B	Single-part chain drive
1	Slide rail
2	Top timing chain
3	Chain tensioner
4	Tensioning rail
5	Bottom timing chain
6	Camshaft sprocket, oil vacuum pump
7	Drive chain, oil vacuum pump
8	Guide rail
9	Timing chain

# B58TU Engine

## 2. Engine Mechanical

The main difference between the chain drive compared with the B58 engine is the move from a two-part timing chain drive to a single-part timing chain drive. Deflection via the intermediate shaft on the top timing chain and the second timing chain is no longer needed. The chains used here are 8 mm sleeve-type chains. Because the intermediate gearing is no longer needed, the number of teeth on the crankshaft (23 teeth) and the VANOS adjuster (46 teeth each) has also changed.

### Chain track

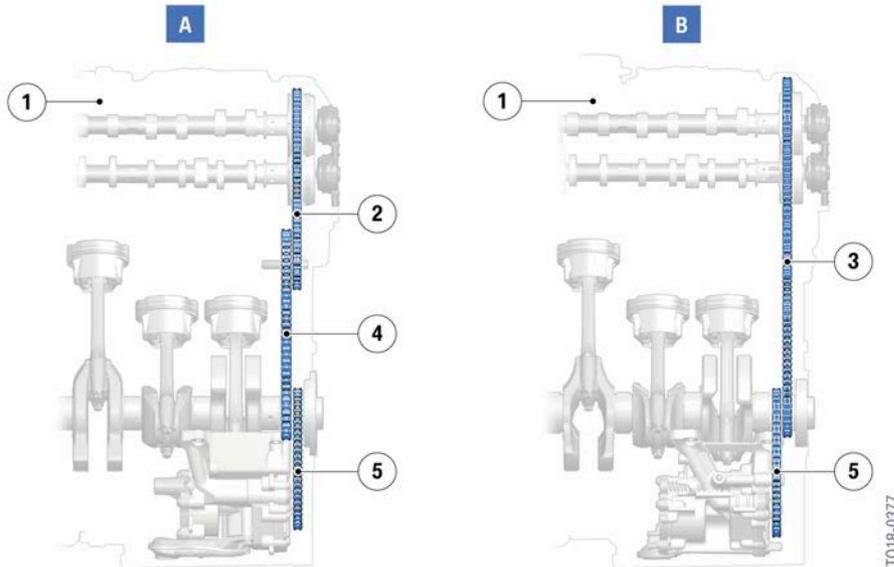

Comparison between chain track of B58 engine and B58TU engine

Index	Explanation
A	Chain track, two-part timing chain drive B58 engine
B	Chain track, single-part timing chain drive B58TU engine
1	6-cylinder engine
2	Upper timing chain
3	Timing chain
4	Lower timing chain
5	Drive chain, oil vacuum pump

The way the combined oil vacuum pump is driven via a separate drive chain from the crankshaft has not changed compared with the Bx8 engines. Only the change of the chain tracks has changed: The drive chain of the oil vacuum pump is now in front of the timing chain.

Dropping the second timing chain offers the following benefits:

- Improved acoustics
- Lower space requirement
- Reduced weight

# B58TU Engine

## 2. Engine Mechanical

### Chain tensioner

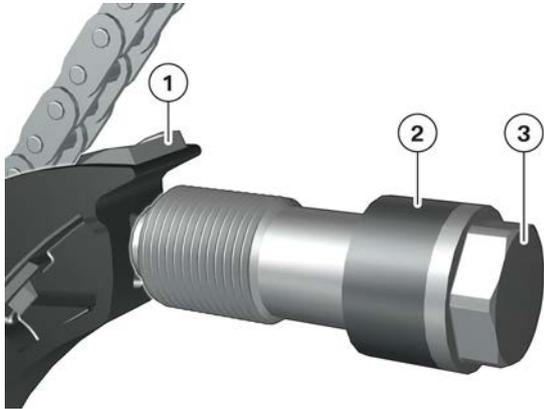

TO17-0371

Chain tensioner, Bx8TU engine

Index	Explanation
1	Tensioning rail
2	Sealing sleeve
3	Chain tensioner with screw thread

Due to the cylinder head manufacturing process, the chain tensioner now has a sealing sleeve with a height of 12.5 mm instead of a sealing ring. The spring force of the chain tensioner lies between 40 Nm (extended) and 90 Nm (retracted).

### 2.3. Valve gear

#### 2.3.1. VANOS



TO17-0364

# B58TU Engine

## 2. Engine Mechanical

<b>Index</b>	<b>Explanation</b>
A	VANOS B58 engine
B	VANOS B58TU engine

Following the changeover from a two-part chain drive to a single-part chain drive, the camshaft sprockets on the VANOS now need 46 teeth instead of the previous 36 teeth. To compensate for the additional weight of the larger camshaft sprockets, the adjuster was designed to be shorter and more compact.

# B58TU Engine

## 3. Vacuum Supply

### 3.1. Vacuum pump

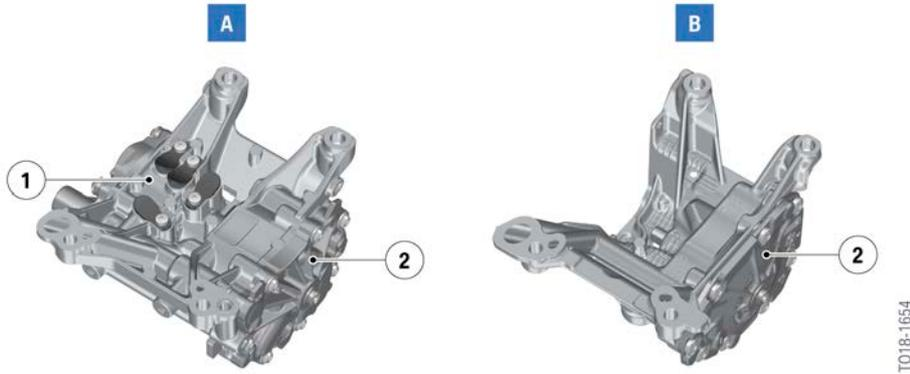

Oil vacuum pump, B58/B58TU engine

Index	Explanation
A	B58 engine, tandem oil pump with integrated vacuum pump
B	B58TU engine, oil pump
1	Vacuum pump
2	Oil pump

Vehicles with a gasoline engine and "traditional brake system" need a vacuum pump to boost the pedal force. In vehicles with a gasoline engine and DSCi brake system no vacuum boost is required as in the DSCi brake system the pedal force is boosted hydraulically. The graphics show the oil pumps of the B58 engine and the B58TU engine with combined vacuum pump and without vacuum pump.

# B58TU Engine

## 4. Cooling System

### 4.1. Split cooling

A new development for the B58TU engine is the split cooling. A cooling concept which is used the N63 TU2.

The split cooling function uses the electric split cooling valve, eSCV, to enable on-demand decoupling of the crankcase from the coolant flow both in the warm-up phase and in partial load operation. In this situation, the coolant is exclusively routed through the cylinder head. The engine reaches its operating temperature more quickly in the warm-up phase, and can be operated with reduced emissions in partial load operation.

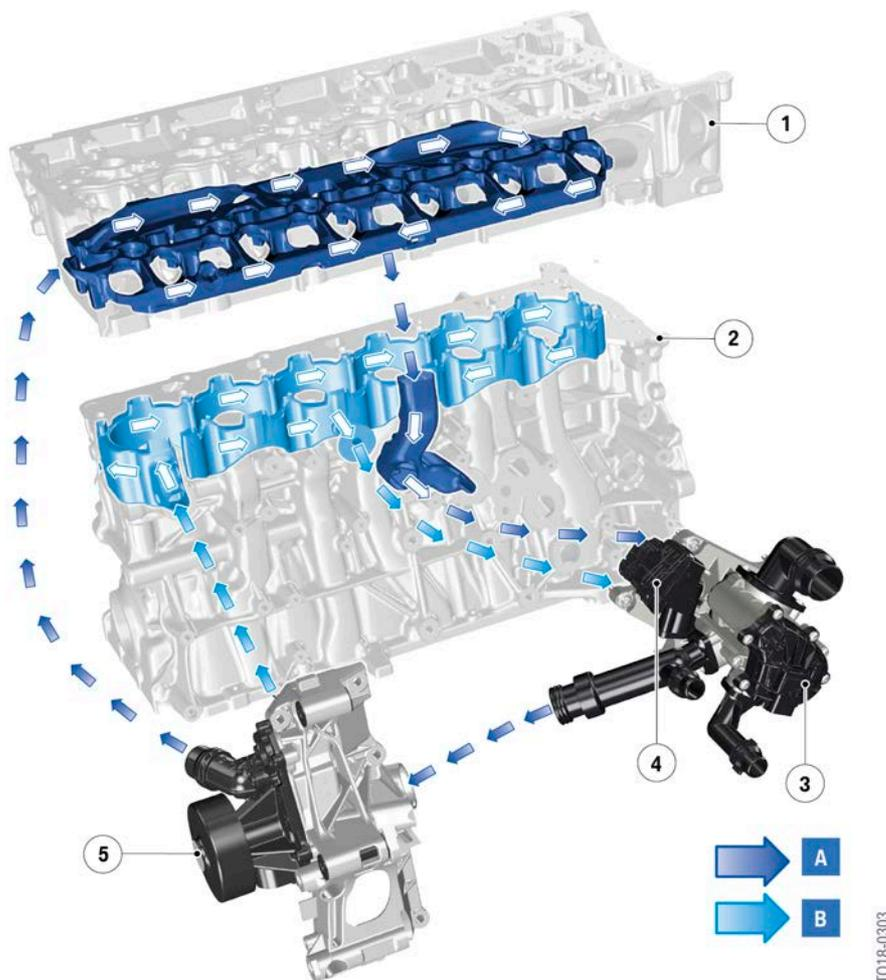

Cooling circuit, B58TU engine

# B58TU Engine

## 4. Cooling System

<b>Index</b>	<b>Explanation</b>
A	High cooling requirement, split cooling cylinder head
B	Low cooling requirement, split cooling crankcase
1	Cylinder head
2	Crankcase
3	Heat management module
4	Electric Split Cooling Valve (eSCV)
5	Coolant pump

# B58TU Engine

## 4. Cooling System

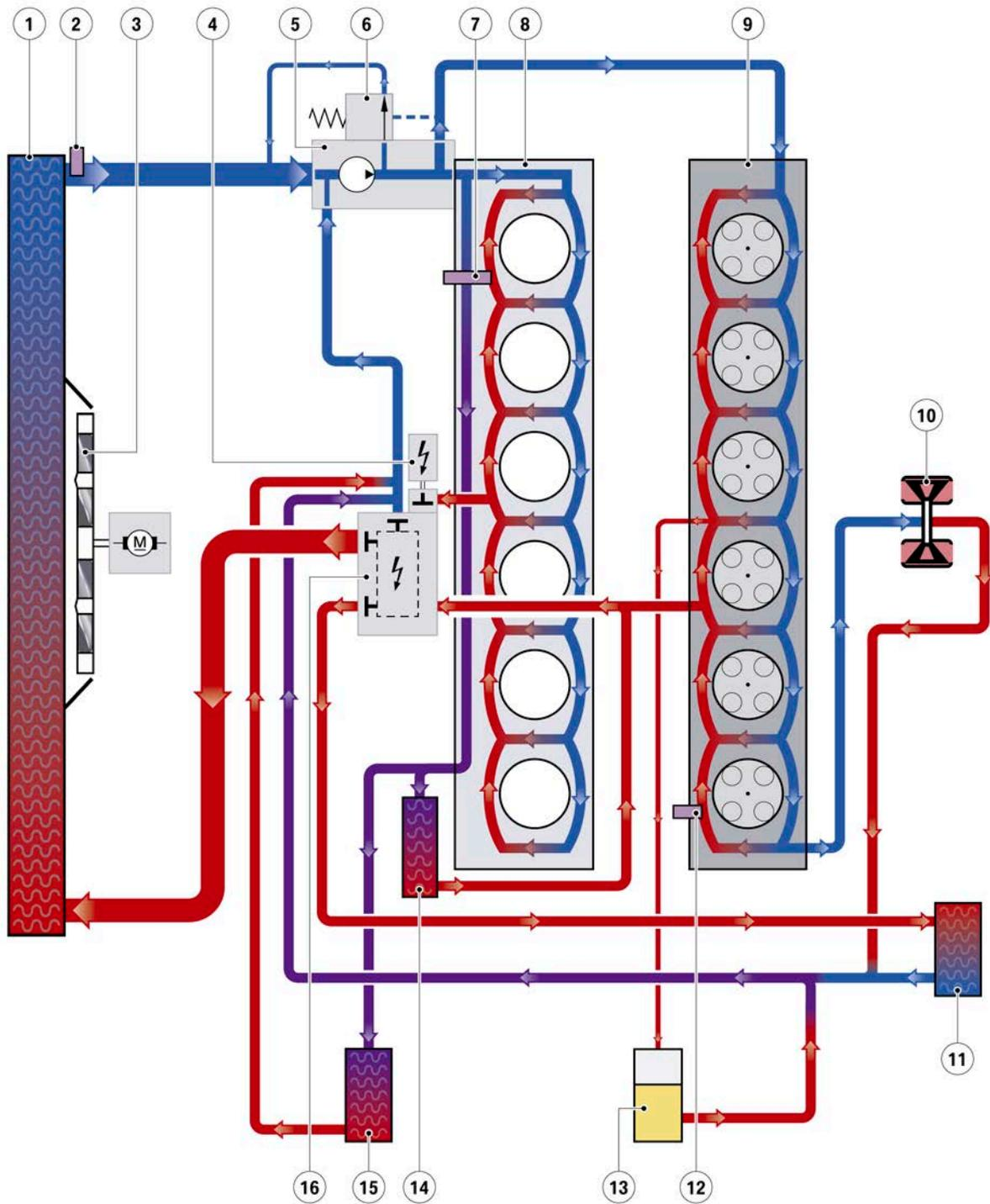

Cooling system for B58TU engine

T018-0297

# B58TU Engine

## 4. Cooling System

Index	Explanation
1	Coolant radiator
2	Coolant temperature sensor, radiator outlet
3	Electric fan
4	Electric split cooling valve
5	Coolant pump
6	Pressure relief valve
7	Coolant temperature sensor, crankcase
8	Crankcase
9	Cylinder head
10	Exhaust turbocharger
11	Heating
12	Component temperature sensor
13	Expansion tank
14	Engine oil/coolant heat exchanger
15	Transmission oil/coolant heat exchanger
16	Heat management module

In split cooling, the cooling requirements for the crankcase and the cylinder head are managed by the electric split cooling valve. The fact that the engine reaches operating temperature more quickly again translates to substantial consumption and emission reductions.

### 4.1.1. Split cooling valve

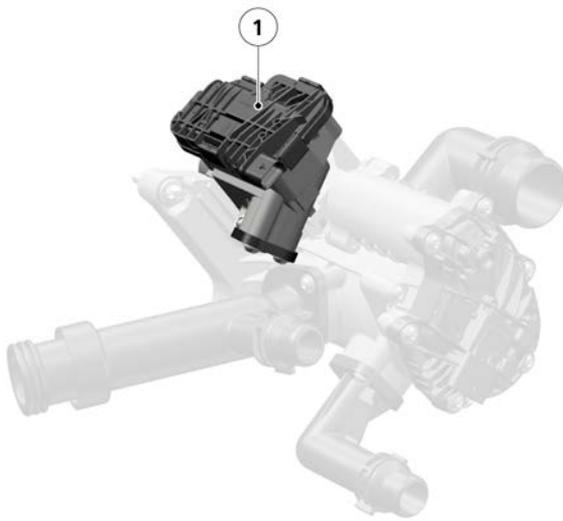

T018-1411

Heat management module with electric split cooling valve

# B58TU Engine

## 4. Cooling System

Index	Explanation
1	Electric split cooling valve

To guarantee optimal heat distribution during the cylinder head and crankcase warm-up, the coolant supply for the cylinder head and crankcase is controlled individually. The coolant is controlled by the Digital Motor Electronics (DME). The coolant is distributed by the electric split cooling valve on the heat management module in the warm-up phase such that substantially more coolant is available to the cylinder head than to the crankcase. Depending on the engine's operating condition, the Digital Motor Electronics (DME) decide on the distribution of the coolant quantity to the cylinder head and the crankcase as required.

Direct current motor (DC)	B58TU engine
Voltage range in volts (V)	6 - 16
Power consumption in ampere (A)	0.4 - 1
Control frequency of the DC motor (kHz)	1
Gear reduction	1 : 440
Adjustment speed per second	65.5°

### 4.1.2. Switching logic of split cooling valve

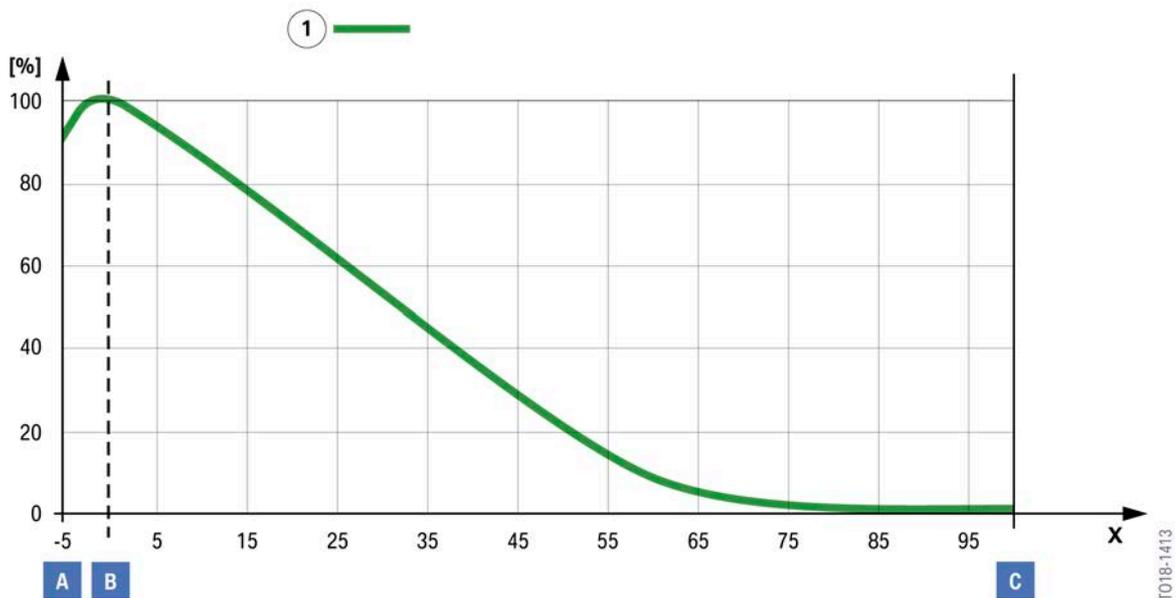

Switching logic of electric split cooling valve

T018-1413

# B58TU Engine

## 4. Cooling System

Index	Explanation
A	End stop
B	Delivery position
C	End stop
%	Valve opening in %
x	Rotary valve position in degrees, angle of rotation
1	Rotary valve

The diagram shows the switching logic of the electric split cooling valve. Depending on the operating condition and coolant temperature of the engine, as well as the driver's desired load, the Digital Motor Electronics (DME) releases the coolant access from the crankcase to a greater or lesser extent via the rotary valve of the split cooling valve. The coolant now also flows through the crankcase and cools components.



A bleeding procedure in line with the repair instructions is required following a part exchange in the cooling system or refilling of the cooling system. Filling **without** a vacuum filler device (watering can filling) is **not approved!** There is a risk of engine damage in case of failure to comply! The filling specification **must** be observed!

Operation of the vehicle is not permitted without completing the entire filling and bleeding routine. There is a risk of functional limitations or overheating.

### 4.2. Heat management module

The function of the heat management module is similar to that of the heat management module of the B58 engine.

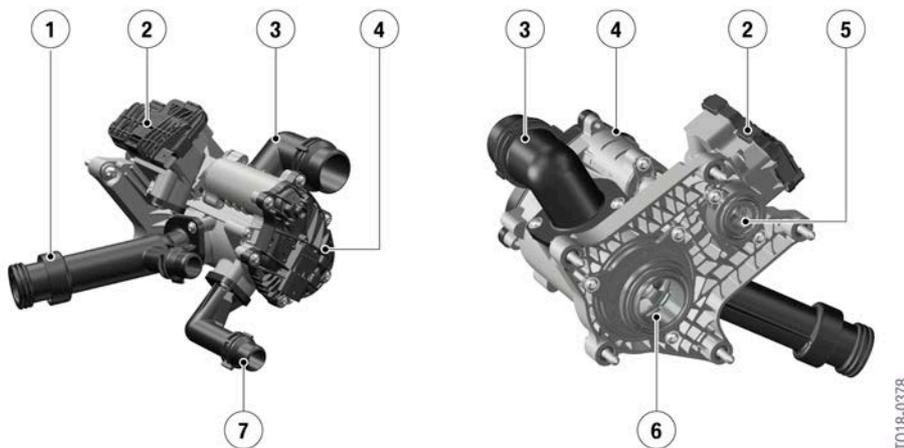

B58TU engine heat management module

# B58TU Engine

## 4. Cooling System

Index	Explanation
1	Coolant output towards the coolant pump
2	Electric split cooling valve
3	Coolant outlet to coolant radiator
4	Electrical actuator, heat management module
5	Coolant entry, split cooling valve
6	Coolant entry, heat management module
7	Coolant outlet, heating

A rotary valve inside the heat management module ensures needs-driven cooling of the various engine components. The opening cross-sections of the various coolant ducts can be opened or closed variably. A position sensor in the electrical actuator of the heat management module forwards the current position of the rotary valve to the Digital Motor Electronics (DME). The exact position of the rotary valve can thus be determined so that it opens or closes a precisely defined cross-section with respect to the various coolant ducts. Adjusting the cross-sections ideally adapts the flow rates of the coolant ducts connected to the heat management module to the engine operating points. To correctly position the rotary valve, the Digital Motor Electronics (DME) require information including the coolant temperature from the coolant temperature sensor, and the material temperature of the cylinder head from the component temperature sensor. Warm-up and cooling of the engine and the supply to ancillary components can be implemented as driven by requirements, thus optimizing consumption.

The following tables provide an overview of the technical data of the heat management modules:

Direct current motor (DC)	B58 engine	B58TU engine
Voltage range in volts (V)	6 - 16	9 - 16
Power consumption in ampere (A)	0.3 - 1.5	0.5 - 0.8
Gear reduction	1 : 492	5 : 769
Adjustment speed per second	40°	64°

Position sensor	B58 engine	B58TU engine
Voltage range in volts (V)	4.5 - 5.5	4.5 - 5.5
Power consumption in milliampere (mA)	20 - 35	20 - 25
Output signal	SENT report*	SENT report*
Rotational angle of the rotary valve	200°	165°

\* SENT report = **S**ingle **E**dge **N**ibble **T**ransmission

# B58TU Engine

## 4. Cooling System

### 4.3. Operating strategy of the heat management module

The following graphic shows the positions of the rotary valve as the coolant temperature increases.

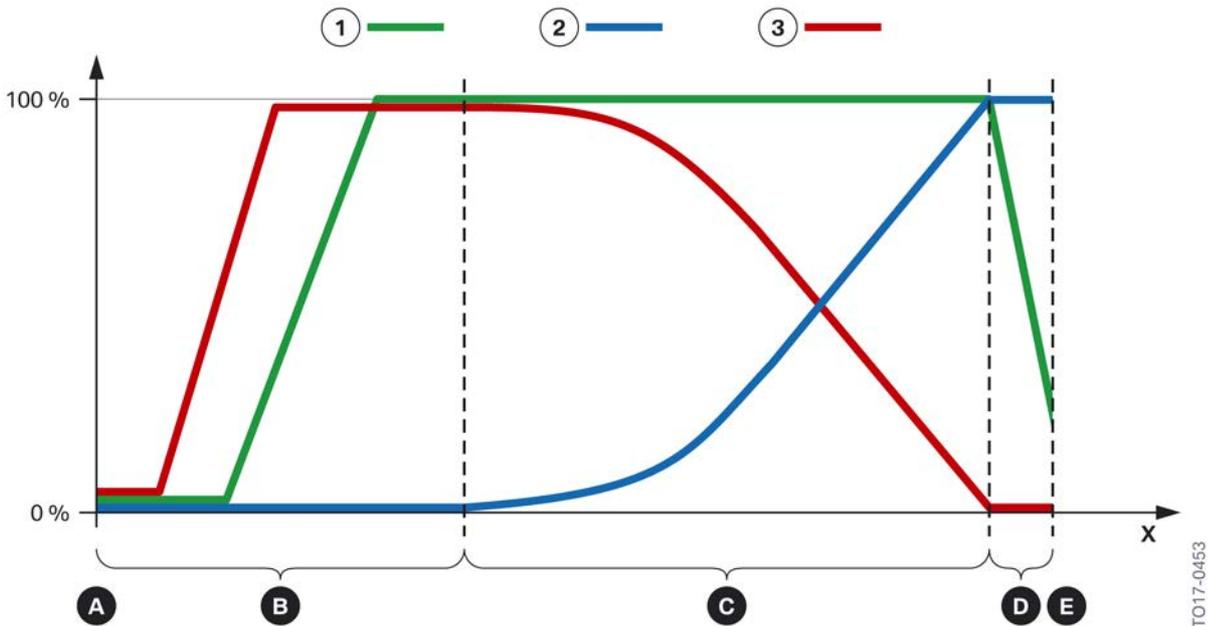

Circuit diagram of heat management module in B58TU engine

Index	Explanation
0 %	Rotary valve closed
100%	Rotary valve open
A	Cold start
B	Warm-up phase
C	Operating temperature
D	Transition from normal operation to maximum cooling requirement
E	Maximum cooling requirement
x	Rotational angle in angular degrees
1	Heater circuit
2	Main coolant circuit
3	Minor coolant circuit

The openings on the rotary valve vary the cross-sections of the different coolant ducts as a function of the rotational angle of the rotary valve. The following graphics schematically represent the various engine operation phases, from cold start to maximum cooling requirement.

# B58TU Engine

## 4. Cooling System

### 4.3.1. Cold-start phase

Point A in the heat management module circuit diagram designates the cold start with an engine that has completely cooled down.

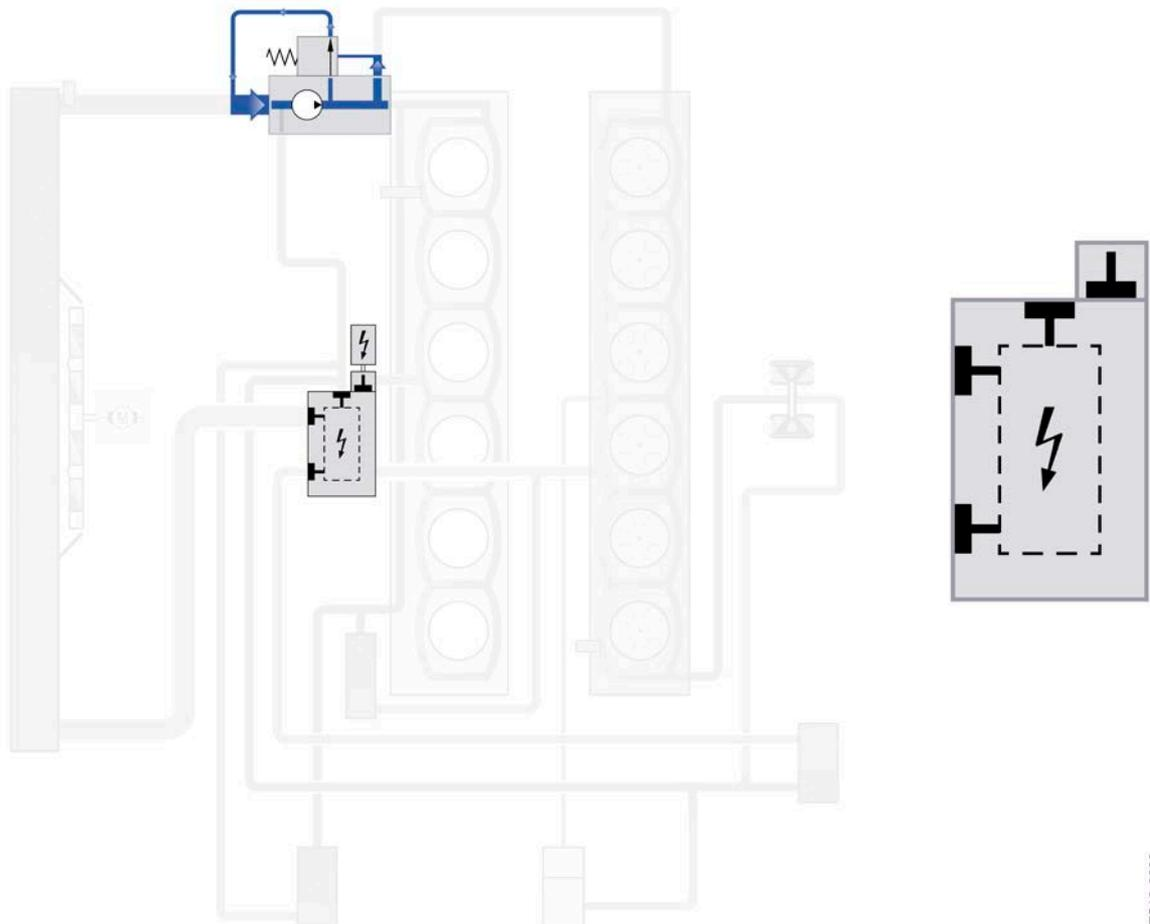

Cold-start phase, Bx8TU engine

In the cold-start phase, the coolant circulates exclusively via a bypass in the coolant pump. The rotary valve in the heat management module closes the coolant lines so that the excess pressure that builds up opens the pressure relief valve in the coolant pump (opening pressure 2.1 bar) and the coolant is recirculated in the coolant pump.

Because the coolant circuits through the exhaust turbocharger and the ventilation line of the cylinder head cannot be closed, a low volumetric flow is returned to the coolant pump here.

T018-0298

# B58TU Engine

## 4. Cooling System

### 4.3.2. Warm-up phase

Area B in the circuit diagram for the heat management module shows the opening angle of the rotary valve in the warm-up phase.

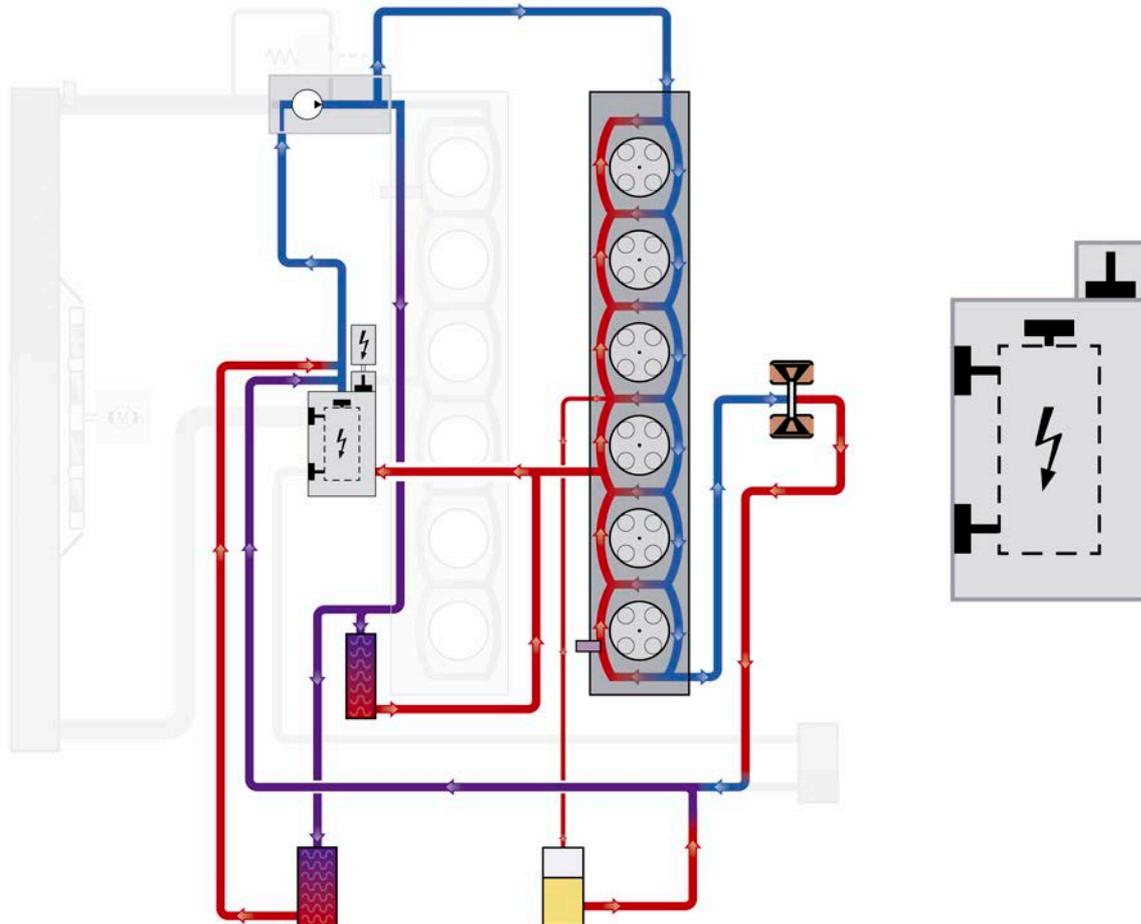

Warm-up phase, Bx8TU engine

In the warm-up phase, the heat management module additionally opens the connection to the heating in addition to opening the bypass line. The coolant flows through the cylinder head, the exhaust turbocharger and the engine oil/coolant heat exchanger. The electric split cooling valve is closed; no coolant flows through the engine block (split cooling).

T018-0299

# B58TU Engine

## 4. Cooling System

### 4.3.3. Operating temperature

The positions of the rotary valve at engine operating temperature are shown by area C of the circuit diagram.

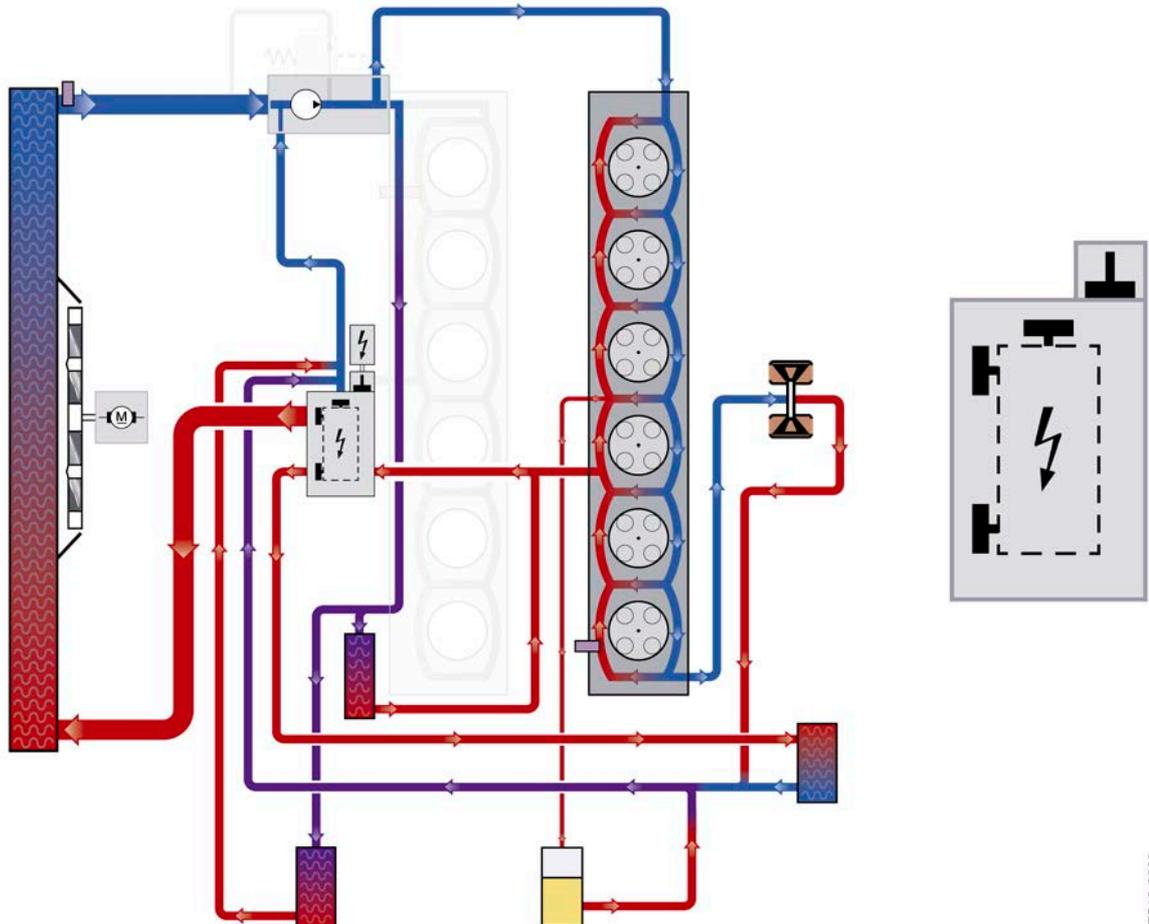

Operating temperature, Bx8TU engine

The graphic shows control with the engine at operating temperature. The position of the rotary valve means that the cross-sections of the respective coolant lines are open to a greater or lesser extent depending on the coolant temperature. The coolant flows with a varying volumetric flow through the small coolant circuit, the large coolant circuit and the heater circuit. Depending on the load request, the crankcase's coolant connection is opened by the electric split cooling valve, thus cooling the crankcase. Large engine operation ranges are covered with the crankcase coolant circuit closed.

TO18-0300

# B58TU Engine

## 4. Cooling System

### 4.3.4. Maximum cooling requirement

The maximum cooling requirement is shown at point E of the heat management module circuit diagram.

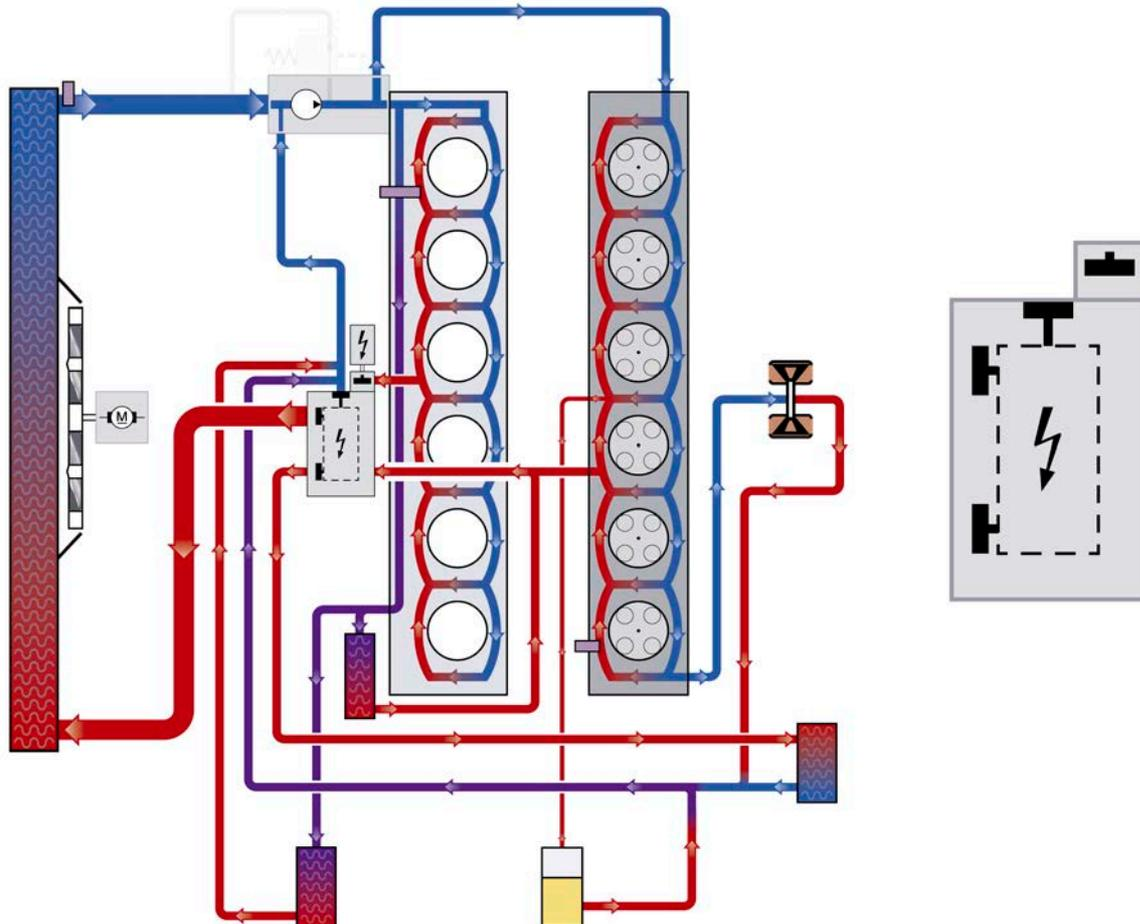

Maximum cooling requirement, Bx8TU engine

To provide maximum cooling at high dynamic loads and/or high ambient temperatures, the radiator connection is fully opened (100%) and the small coolant circuit is completely closed. Additionally, the heater circuit is 90% closed to achieve the maximum cooling thanks to the maximum coolant volumetric flow through the large coolant circuit.

T018-0301

# B58TU Engine

## 4. Cooling System

### 4.4. Coolant pump

The layout and function of the coolant pump have been revised and adapted to match the cooling concept of the Bx8 TU engines.

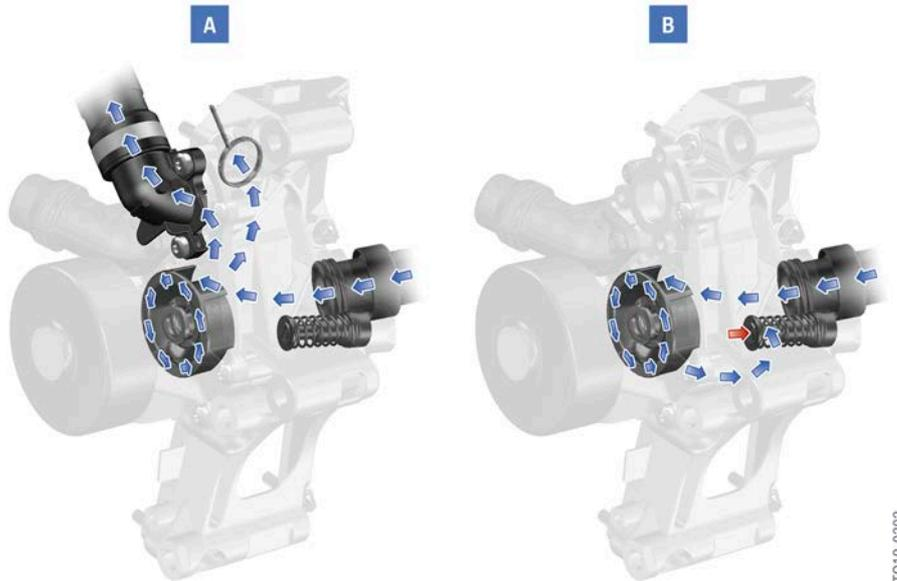

Coolant pump, Bx8TU engine

Index	Explanation
A	Pressure relief valve closed (pressure < 2.1 bar)
B	Pressure relief valve opened (pressure > 2.1 bar)

A pressure relief valve is installed in the mechanical coolant pump housing. In combination with the heat management module, the pressure relief valve on the one hand ensures that the engine operating temperature is reached more quickly, while at the same time reducing leaks and component damage due to high pressure in the cooling system.

If an excess pressure of more than 2.1 bar builds up in the coolant circuits, the pressure relief valve opens and releases a bypass channel. The coolant is now exclusively circulated in the pump body. Once the pressure drops below 2.1 bar or the engine speed rises above 3000 rpm, the pressure relief valve closes and the coolant is again routed through the engine's coolant ducts.

# B58TU Engine

## 5. Intake Air and Exhaust System

### 5.1. Crankcase monitoring

#### 5.1.1. On-board diagnosis

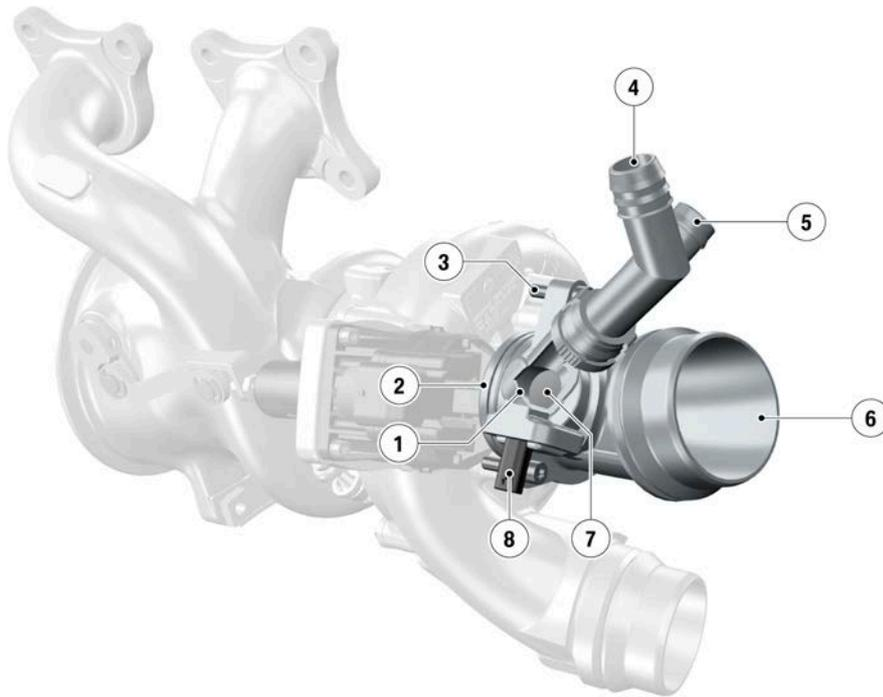

T018-0307

Feed-in point of the blow-by gases to the clean air line upstream from the exhaust turbocharger

Index	Explanation
1	Non-return valve
2	Connection to exhaust turbocharger
3	Captive screws
4	Crankcase bleeding connection
5	Tank ventilation connection
6	Connection to clean air line
7	Aluminum heating pipe
8	Electrical connection of heating element

Owing to the stricter legislation in the USA, the engines for the US market have an OBD concept "pressure sensor". With a differential pressure sensor in the tank ventilation system and the hot film air mass meter, leaks in the crankcase ventilation, tank ventilation, as well as the blow-by lines can be identified. Via a feed-in point at the exhaust turbocharger the blow-by gases are fed back into the clean air line of the air intake system.

# B58TU Engine

## 5. Intake Air and Exhaust System

### 5.2. Exhaust turbocharger

#### 5.2.1. B58TU exhaust turbocharger



Exhaust turbocharger in the B58TU engine

Index	Explanation
A	Exhaust turbocharger made of steel, for cylinder head-integrated exhaust manifold ZIAK <sup>1</sup>
B	Exhaust turbocharger made of steel, for non cylinder head-integrated exhaust manifold nZIAK <sup>2</sup>

ZIAK<sup>1</sup> = cylinder head-integrated exhaust manifold

nZIAK<sup>2</sup> = non cylinder head-integrated exhaust manifold

Due to the exhaust manifold integrated into the cylinder head, the exhaust manifold and exhaust turbocharger housing are no longer designed as a single component for the B58TU engine. This means that the exhaust turbocharger can be individually replaced. The charging pressure is still controlled by an electrical wastegate valve.

The exhaust manifold and exhaust turbocharger housing on the B58TU engine can be implemented either as one part or separately. Depending on the engine version, the exhaust turbocharger can be replaced individually. The following table shows which variant is used by which engine.

	B58TU engine	
Engine version	B58B30M1	B58B30O1
Cylinder head	Cylinder head-integrated exhaust manifold	Non cylinder head-integrated exhaust manifold
Exhaust turbocharger	Steel	

# B58TU Engine

## 6. Fuel System

### 6.1. Fuel preparation

The fuel preparation has been modified to meet the requirements of emission legislation. The high pressure pump and the injectors have been revised and designed for a fuel injection pressure of 350 bar.

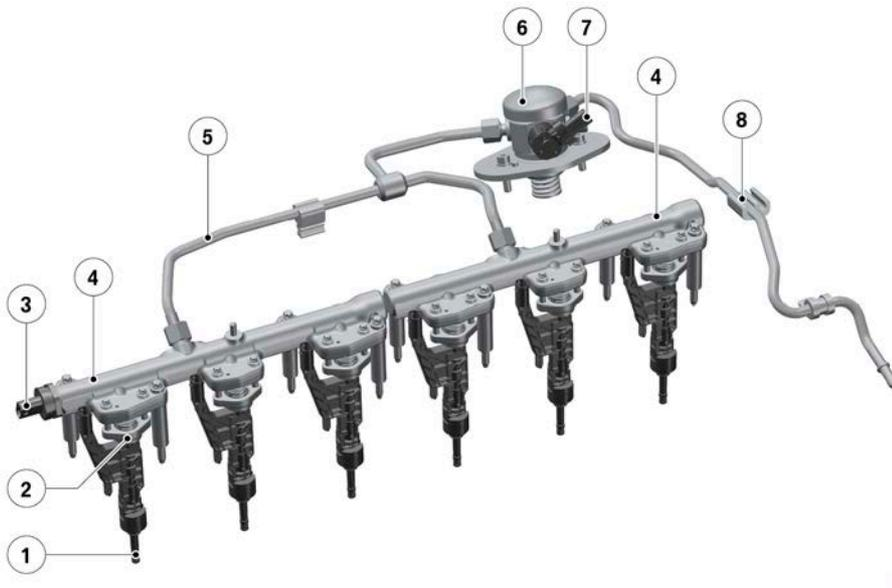

T018-0305

Fuel preparation, B58TU engine

Index	Explanation
1	Injector
2	Holding clamp
3	Rail pressure sensor
4	Rail
5	High-pressure line
6	High pressure pump
7	Quantity control valve
8	Fuel feed line



Strict cleanliness must be observed when carrying out any work on the fuel system!

# B58TU Engine

## 6. Fuel System

### 6.1.1. Direct rail

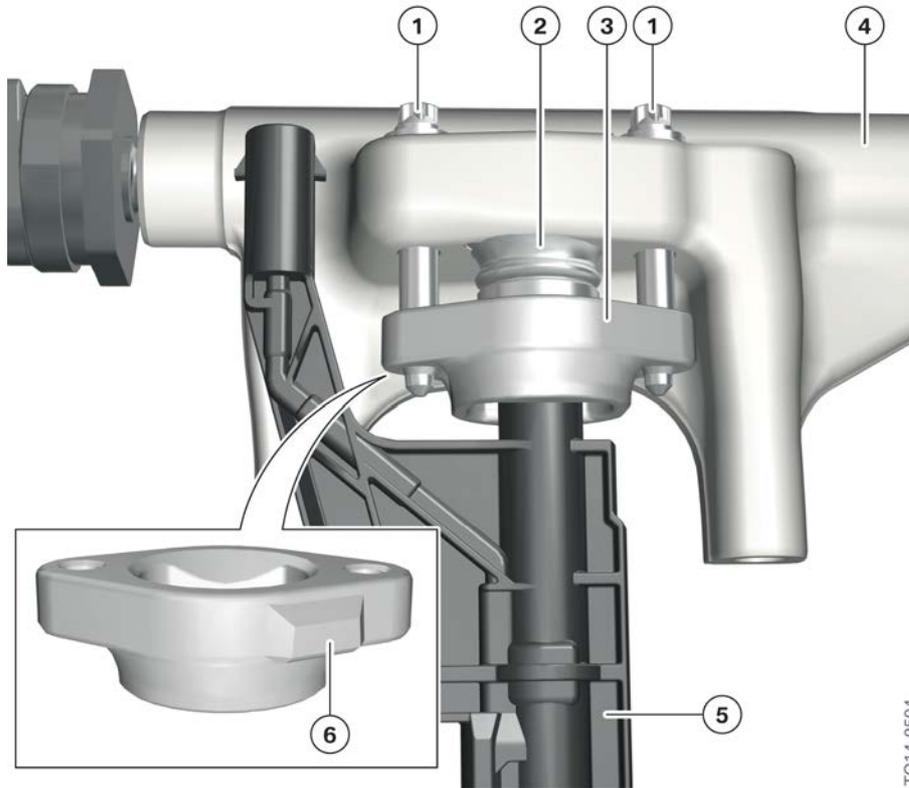

Mounting the injectors

Index	Explanation
1	Mounting bolts
2	Plastic sleeve
3	Holding clamp with bayonet fitting
4	Rail
5	Solenoid valve injector
6	Cast lug

The solenoid valve injectors are fastened to the holding clamp with a bayonet fitting. There is a plastic sleeve between the holding clamp and direct rail. This is not designed to collect escaping fuel. This is only used to support a helium leakage test during pre-assembly at the factory in order to check the tightness. After the initial assembly, this plastic sleeve is of no relevance to the engine operation. When the solenoid valve injectors are reinstalled or replaced, the plastic sleeves are no longer required and do not need to be reinserted.

The mounting bolts of the holding clamp must be replaced each time they are released.

# B58TU Engine

## 6. Fuel System



---

The housing on the solenoid valve injectors is sensitive to excessive tensile forces and excessive rotational angles. When removing and installing the solenoid valve injectors, the procedure in the current repair instructions must be followed! If the solenoid valve injectors are damaged, fuel may be discharged.

---

### 6.1.2. Solenoid valve injector

#### Measures at the solenoid valve injector

The following graphic illustrates the differences between the EURO 6b and EURO 6c versions:

# B58TU Engine

## 6. Fuel System

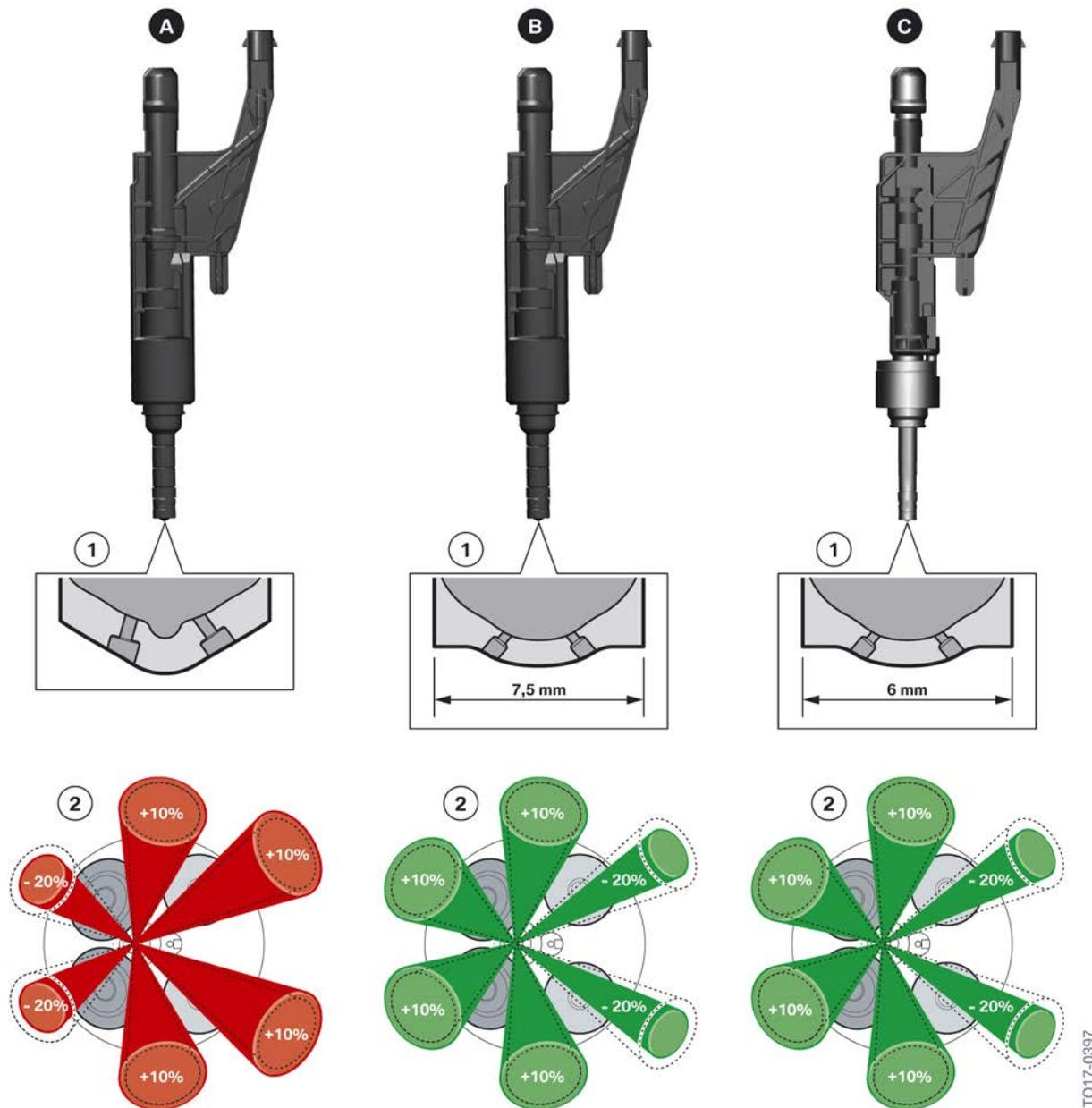

EURO 6 measures, solenoid valve injector

Index	Explanation
A	Solenoid valve injector HDEV5 Bx8 engine, EURO 6b
B	Solenoid valve injector HDEV5 EVO Bx8 engine, EURO 6c
C	Solenoid valve injector HDEV6 Bx8TU engine, EURO 6c
1	Injector seat
2	Injection pattern and volumetric distribution

T017-0397

# B58TU Engine

## 6. Fuel System

The Bx8TU engines use the HDEV6 solenoid valve injector by Bosch. Due to the more stringent exhaust gas emission regulations required to meet the EURO 6c exhaust emission standards, technical changes were again made to the solenoid valve injectors.

Due to the fuel system pressure increase from 200 bar to 350 bar, the solenoid valve injectors HEDV6 were optimized using suitable materials and coatings. The injection pattern and volumetric distribution have not changed compared with the HDEV5 EVO.



---

**The repair instructions that are currently valid must be carefully followed** when removing and installing the injectors in Service. An excessive rotational angle at the injector shank, and excessive tensile and compressive forces during removal and installation can lead to damage and therefore leaks in the fuel system.

---

# B58TU Engine

## 7. Engine Electrical System

### 7.1. Digital Motor Electronics (DME)

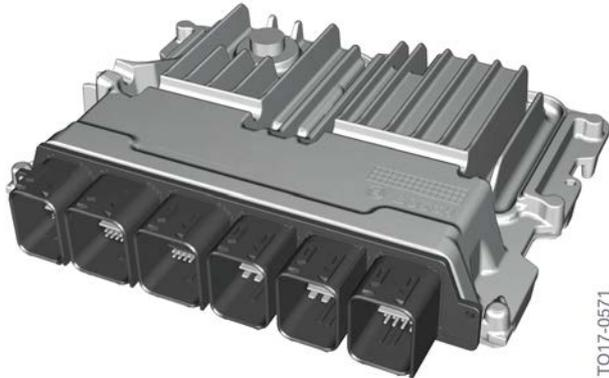

DME 8 control unit

The 8th generation engine electronics form a common control unit platform for gasoline and diesel engines that have been used since modular engines were introduced. Its appearance is characterized by a uniform housing and a uniform connector strip. The hardware inside has been adapted to the respective applications. The Bx8TU engines have the DME 8 engine electronics generation. Depending on the engine version, the Digital Motor Electronics (DME) will be given a specific designation.

DME 8.xTyz (x = number of cylinders, Ty = vehicle electrical system architecture, z = H (hybrid)) can be decoded as follows:

- DME 8.4T1 = B48
- DME 8.4T0.H = B48 PHEV
- DME 8.6T0 = B58
- DME 8.8T0 = N63

# B58TU Engine

## 7. Engine Electrical System

### 7.2. Component temperature sensor

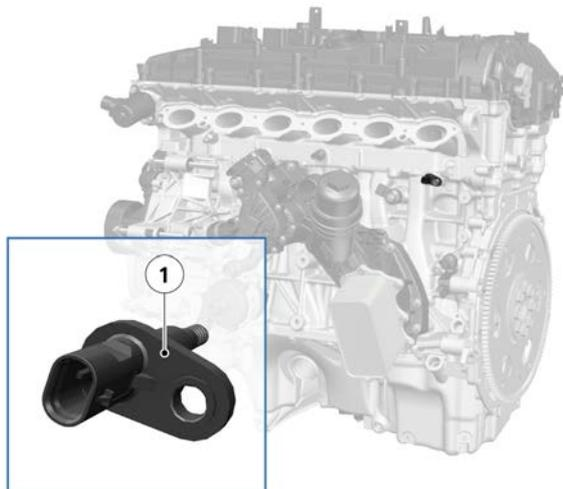

T018-0339

B58TU engine, component temperature sensor

Index	Explanation
1	Component temperature sensor

The B58TU engine uses a component temperature sensor in addition to the coolant temperature sensor to control the coolant more precisely with the heat management module. Except for the installation location, no changes have been made to the function of the component itself. It records the material temperature of the crankcase close to the cylinder head in the area of the 6th cylinder and forwards this to the DME engine control unit. As a result, power, consumption and pollutant emissions can be influenced even more efficiently.

A variable temperature resistance (negative temperature coefficient), which covers a temperature range from - 40° C to 150° C (- 40° F to 302° F), has been tried and tested. The temperature is transferred to the sensor using an elastic heat coupler attached to the outside of the sensor.



