

Reference Manual



G32 COMPLETE VEHICLE



Technical Training

The information contained in this manual is not to be resold, bartered, copied or transferred without the express written consent of BMW of North America, LLC ("BMW NA").

Technical training.
Product information.
G32 Complete Vehicle



BMW Service

Edited for the U.S. market by:
BMW Group University
Technical Training

ST1709

8/1/2017

General information

Symbols used

The following symbol is used in this document to facilitate better comprehension or to draw attention to very important information:



Contains important safety information and information that needs to be observed strictly in order to guarantee the smooth operation of the system.

Information status and national-market versions

BMW Group vehicles meet the requirements of the highest safety and quality standards. Changes in requirements for environmental protection, customer benefits and design render necessary continuous development of systems and components. Consequently, there may be discrepancies between the contents of this document and the vehicles available in the training course.

This document basically relates to the European version of left hand drive vehicles. Some operating elements or components are arranged differently in right-hand drive vehicles than shown in the graphics in this document. Further differences may arise as the result of the equipment specification in specific markets or countries.

Additional sources of information

Further information on the individual topics can be found in the following:

- Owner's Handbook
- Integrated Service Technical Application.

Contact: conceptinfo@bmw.de

©2017 BMW AG, Munich

Reprints of this publication or its parts require the written approval of BMW AG, Munich.

The information contained in this document forms an integral part of the BMW Group Technical Qualification and is intended for the trainer and participants in the seminar. Refer to the latest relevant information systems of the BMW Group for any changes/additions to the technical data.

Information status: **June 2017**
Technical training.

G32 Complete Vehicle

Contents

1.	Introduction	1
1.1.	Overview.....	1
1.2.	Model.....	1
2.	Body	2
2.1.	Dimensions.....	2
2.2.	Silhouette comparison.....	2
2.3.	Material qualities.....	3
2.4.	Tailgate.....	4
2.4.1.	Material.....	4
2.4.2.	Electric motor.....	5
2.5.	Rear door side windows.....	6
2.6.	Roller sunblind.....	6
2.7.	Active rear spoiler.....	8
2.7.1.	Component overview.....	9
2.7.2.	Gear drive unit.....	10
2.7.3.	System wiring diagram.....	11
2.7.4.	Operation and function.....	12
2.7.5.	Notes for Service.....	13
2.8.	Luggage compartment.....	14
2.9.	Interior equipment.....	15
2.9.1.	Overview.....	15
2.9.2.	Seat bench.....	16
2.9.3.	Backrest remote unlocking.....	16
2.9.4.	Backrest adjustment.....	20
3.	Powertrain	21
3.1.	Engine.....	21
3.1.1.	Gasoline.....	21
3.2.	Transmission.....	21
4.	Chassis and Suspension	22
4.1.	Standard equipment.....	22
4.2.	Optional equipment.....	22
4.2.1.	Integral Active Steering.....	23
4.2.2.	Adaptive Drive + 2-axle air suspension.....	23
4.2.3.	Active Roll Stabilization.....	24
4.3.	Further information.....	25
5.	General Vehicle Electronics	26
5.1.	Bus overview.....	26

G32 Complete Vehicle

Contents

5.2.	Exterior lights.....	28
5.2.1.	Headlights.....	28
5.2.2.	Rear lights.....	28
5.2.3.	Light carpet.....	29
5.3.	Shared features with the G30.....	30
6.	Driver Assistance Systems.....	31
6.1.	Overview.....	31
6.2.	Sensors.....	32
6.3.	Package overview.....	33
6.3.1.	Active Driving Assistant.....	33
6.3.2.	Driving Assistant Plus.....	33
6.3.3.	Parking Assistant Package.....	33
7.	Infotainment.....	34
7.1.	Speaker systems.....	34
7.2.	Telephone systems.....	34
7.3.	Accident Assistance.....	35
7.3.1.	Function.....	35
7.3.2.	Requirement.....	36
7.3.3.	Displays.....	36
7.4.	Antenna.....	37
7.4.1.	Overview.....	37
7.4.2.	System wiring diagram.....	38

G32 Complete Vehicle

1. Introduction

1.1. Overview

The BMW 6 Series Gran Turismo (G32) will have its market introduction in Fall of 2017. Although the series designation has changed, the G32 is the successor of the F07 (G32 BMW 6 Series Gran Turismo/F07 BMW 5 Series Gran Turismo).

Gran Turismo (Italian for “grand touring”) is used as the designation for more powerful vehicles in the classic sense. In contrast to pure sports cars, these vehicles were previously characterized more by comfort, a larger interior and greater day-to-day usability for long trips.

With the BMW 6 Series Gran Turismo, BMW offers a vehicle concept which remains unique up to the present day. It combines the sporting character of a sedan with the advantages of a Touring model.



G32 Complete Vehicle

1.2. Model

The following model will be available for the market introduction:

- BMW 640i xDrive

G32 Complete Vehicle

2. Body

2.1. Dimensions

The exterior dimensions of the G32 are shown below. The following table compares the dimensions of the G32 with those of a F07:

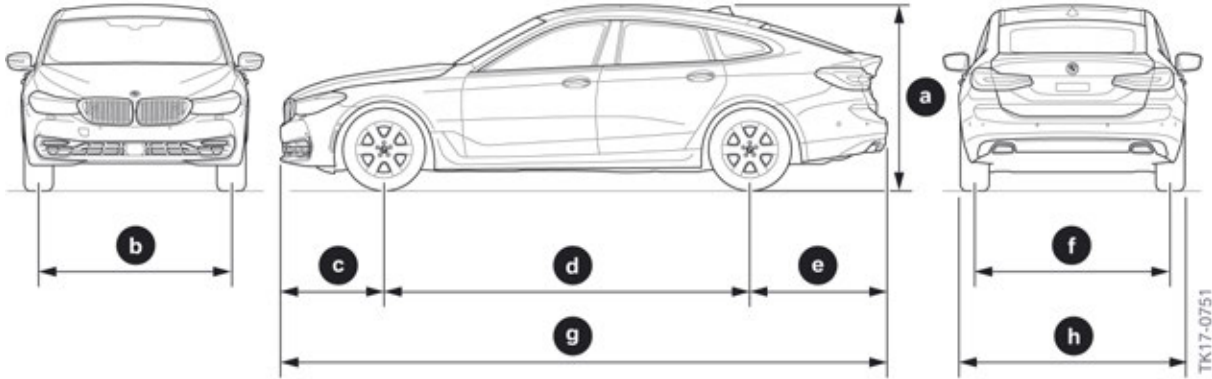

G32 outer dimensions

Index	Explanation		G32	F07
a	Vehicle height, empty	[mm]	1540	1559
b	Front track width, basic wheels	[mm]	1615	1611
c	Front overhang	[mm]	883	838
d	Wheelbase	[mm]	3070	3070
e	Rear overhang	[mm]	1150	1090
f	Rear track width, basic wheels	[mm]	1649	1654
g	Vehicle length	[mm]	5103	4998
h	Width excluding exterior mirrors	[mm]	1902	1901

2.2. Silhouette comparison

A silhouette comparison with the F07 shows the modified dimensions of the G32:

G32 Complete Vehicle

2. Body

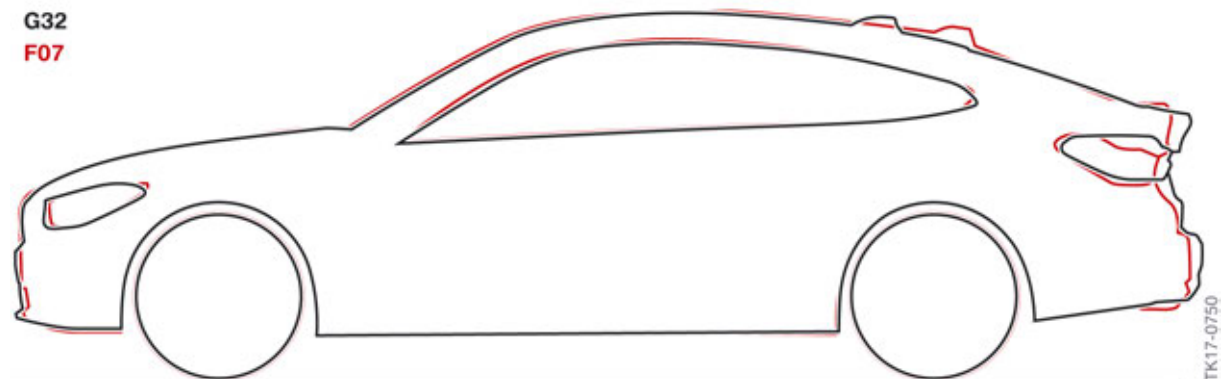

Comparison of an G32 silhouette with an F07 silhouette

2.3. Material qualities

The passenger cell of the G32 is particularly stable thanks to an intelligent use of multiphase steel types and ultra high strength, hot-worked steel types.

Hot-formed steels belong to the group of ultra-high-strength steels. They are used only for safety-relevant components in the body structure, such as the B-pillar reinforcement plate.

Due to their high carbon equivalent, hot-formed steels have limited weldability. This means that they can be joined only by one or more joining methods, e.g. welding, bonding and riveting, in the case of repair.

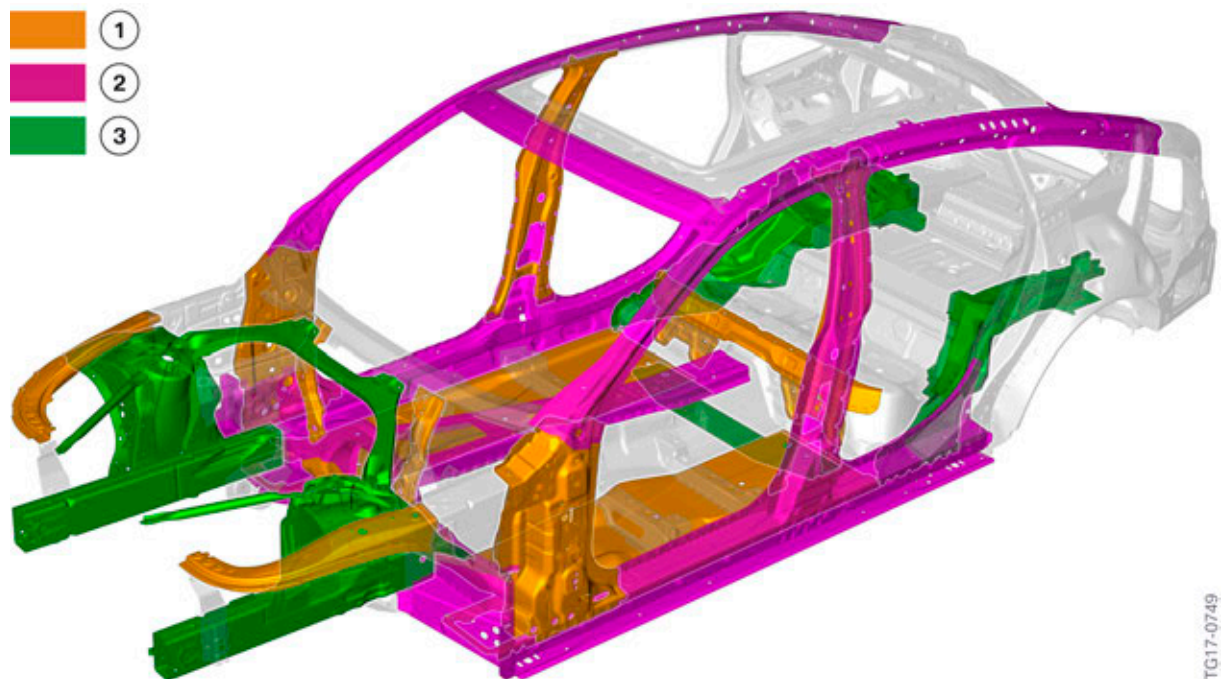

G32 body structure materials

G32 Complete Vehicle

2. Body

Index	Explanation
1	Multi-phase steels (> 300 N/mm ²)
2	Ultra high strength, hot-worked steel types (>900 N/mm ²)
3	Aluminium

2.4. Tailgate

The G32 is equipped with a one-piece tailgate. A “tailgate in tailgate” system like in the F07 will no longer be installed in the G32.



G32 tailgate

2.4.1. Material

The support structure is made of die-cast aluminium for weight optimization. The outer skin of the tailgate is also made of aluminium.

G32 Complete Vehicle

2. Body



TK17-0742

G32 Bodyshell - tailgate

2.4.2. Electric motor

As standard equipment, the G32 features automatic tailgate operation including Soft-Close Automatic (SCA). The tailgate is opened and closed via two electric spindle drives. The tailgate closing operation is protected by a blocking protection function in the tailgate function module (HKFM). The tailgate can be opened and closed by means of a foot movement.



TK17-0741

G32 Electric tailgate drive

G32 Complete Vehicle

2. Body

2.5. Rear door side windows

Unlike the F07, the G32 does not have a fixed side window glass. The doors of the G32 are frameless. Due to the side contours of the rear doors, the side windows of the G32 cannot be fully lowered.

F07

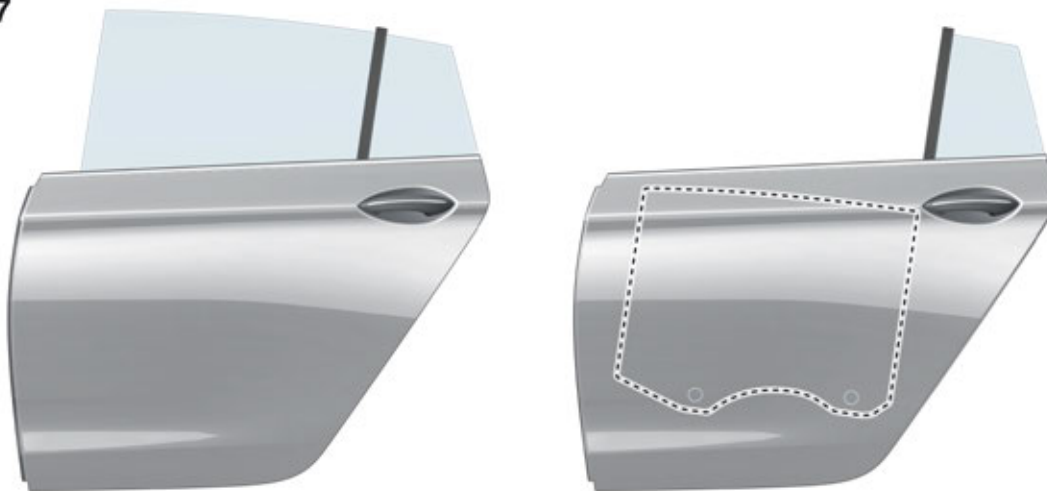

G32

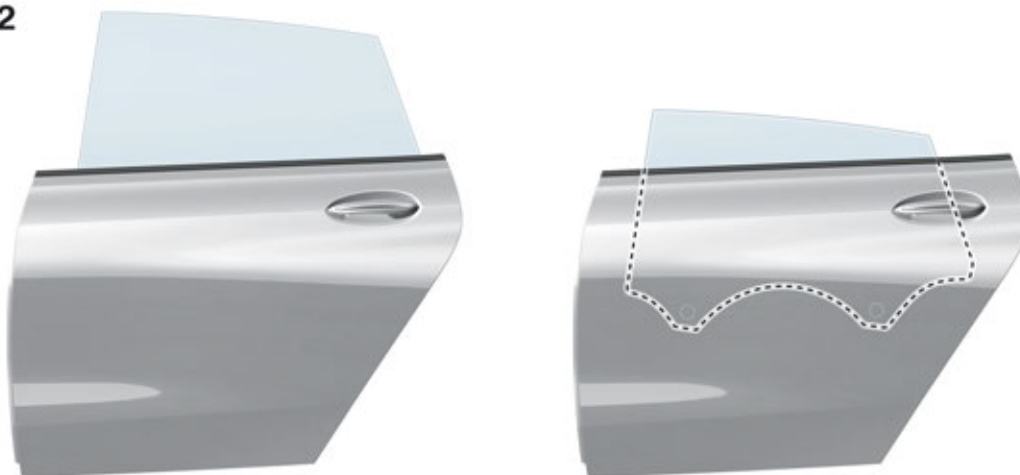

TK17-1055

G32 Comparison of side windows with the F07

2.6. Roller sunblind

Power rear side window shades can be ordered as optional equipment (OE 416) for the rear side windows. Since the roller sunblinds cannot be attached manually due to the lack of a door frame, the sunblinds are extended and retracted electrically. The roller sunblind has a horizontal bar at the top end. The horizontal bar is attached to a telescopic rod which is extended and retracted by means of an electric motor.

G32 Complete Vehicle

2. Body

If the side window is opened when the roller sunblind is extended, the sunblind is retracted in parallel in order to avoid damage to the blind. If the side window is then closed again, the roller sunblind is not automatically extended at the same time.

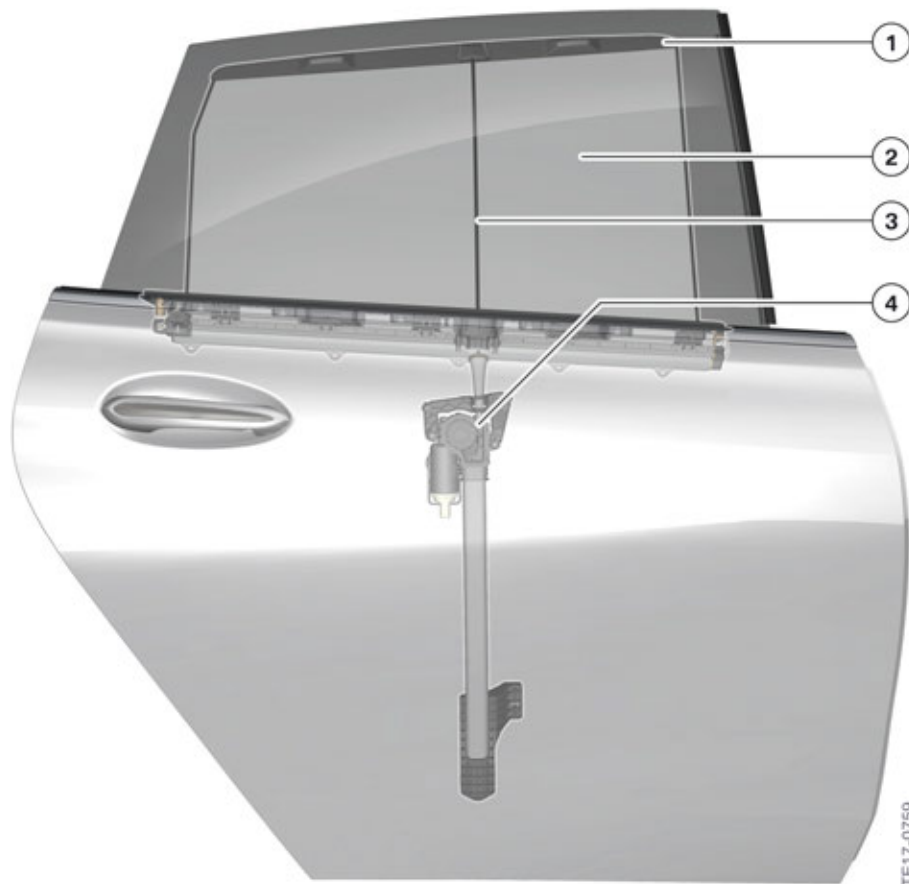

G32 Roller sunblind

Index	Explanation
1	Horizontal bar
2	Roller sunblind
3	Telescopic rod
4	Electric motor

G32 Complete Vehicle

2. Body

2.7. Active rear spoiler



G32 active rear spoiler

The special vehicle proportions of the G32 and the resulting aerodynamic influences make the use of a rear spoiler necessary. Use of the rear spoiler significantly reduces the negative influences of rear-end lift at higher speeds.

In general, lowering the tail lift leads to an increase in the drag coefficient. In the G32, the drag coefficient was even improved slightly through intensive fine tuning of the height, angle of attack and geometry of the rear spoiler.

The rear spoiler is included in the standard equipment of the G32. The rear spoiler is referred to as an active rear spoiler because it is retracted when the vehicle is in rest state and is extended automatically only at higher driving speeds.

G32 Complete Vehicle

2. Body

2.7.1. Component overview

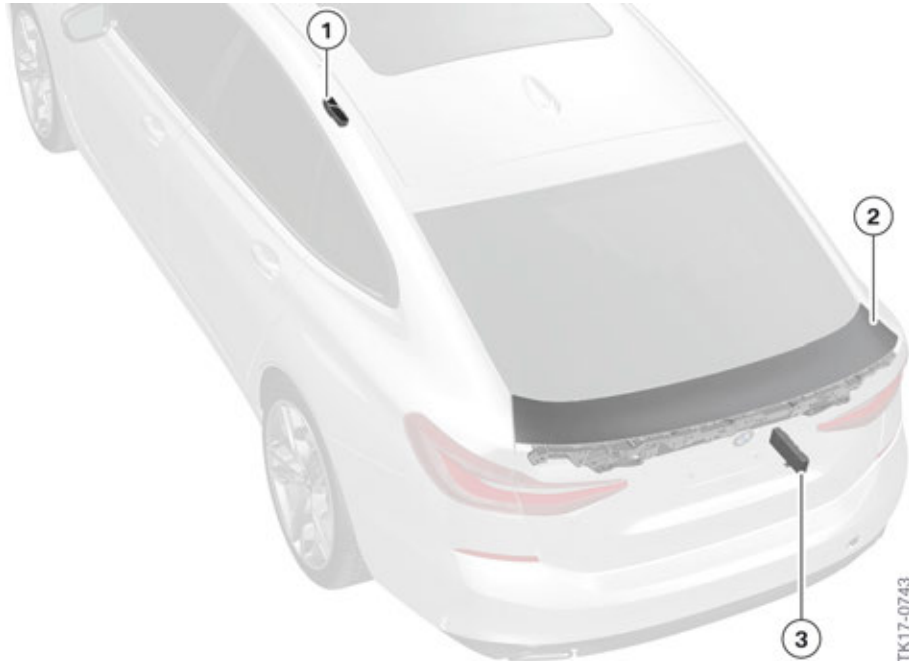

G32 Component overview of rear spoiler

Index	Explanation
1	Operating unit, center console
2	Active rear spoiler
3	Tailgate function module (HKFM)

G32 Complete Vehicle

2. Body

2.7.2. Gear drive unit

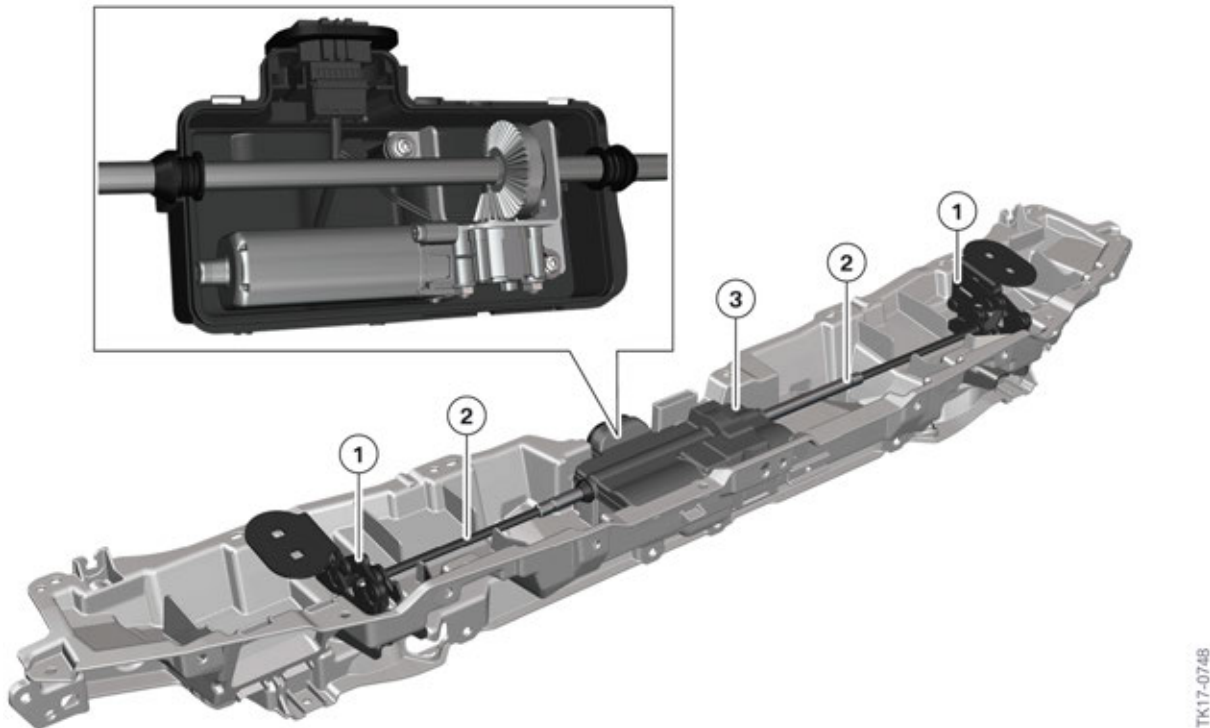

G32 Gear drive unit of rear spoiler

TK17-0748

Index	Explanation
1	Four-joint hinge
2	Drive shaft
3	Electric motor

An electric motor drives the active rear spoiler. The drive shafts are driven via a bevel gear and crown wheel. They in turn actuate the two four-way linkage hinges, at which the spoiler blade is secured.

A hall effect sensor detects the rotations in the electric motor, while another hall effect sensor at the motor/gear unit detects the extended end position of the rear spoiler. A microswitch is also integrated in the motor/gear unit and is used to detect the retracted end position of the rear spoiler.

The tailgate function module HKFM controls and monitors all electrical functions of the active rear spoiler.



Do not operate the rear tailgate with the rear spoiler removed. Once the spoiler is removed disconnect the power supply to the tailgate function module (HKFM). If the tailgate is operated electrically without the spoiler, the reduced weight of the tailgate of approximately 6 lbs (weight of the spoiler) will cause damage to both electric drive spindle units. The tailgate will open to fast and cause irreversible damage to both electric drive spindles. It is also possible to place some pressure on the tailgate when electrically opening to reduce the speed of the tailgate so to prevent it from being damaged.

G32 Complete Vehicle

2. Body

2.7.3. System wiring diagram

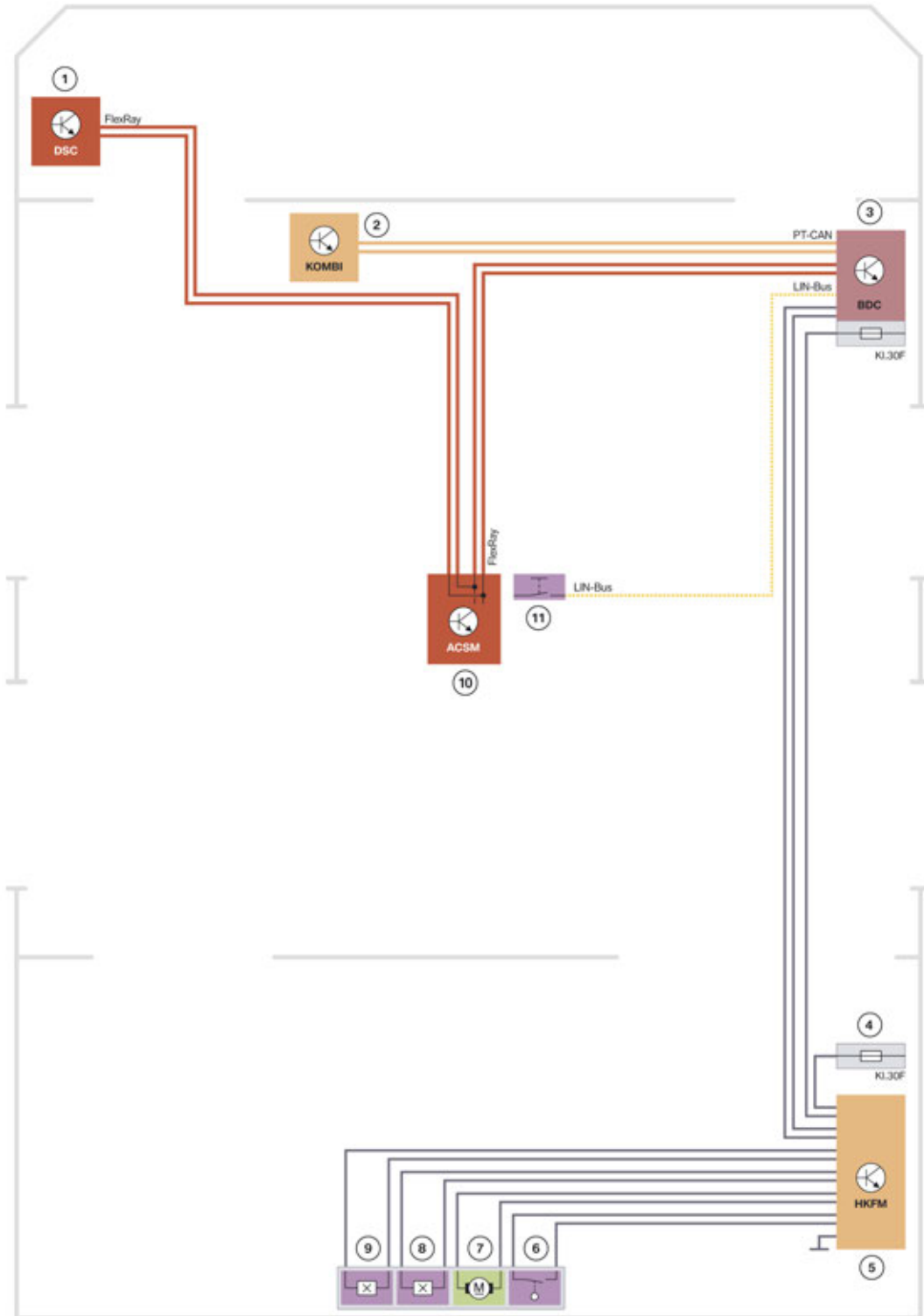

G32 active rear spoiler

TE17-0762

G32 Complete Vehicle

2. Body

Index	Explanation
1	Dynamic Stability Control (DSC)
2	Instrument cluster (KOMBI)
3	Body Domain Controller (BDC)
4	Luggage compartment power distribution box fuse
5	Tailgate function module (HKFM)
6	Microswitches
7	Electric motor
8	Hall effect sensor
9	Hall effect sensor
10	Advanced Crash Safety Module (ACSM)
11	Rear spoiler button

2.7.4. Operation and function

The rear spoiler is always fully retracted or extended during operation. It cannot be adjusted to intermediate settings. The spoiler can be activated either manually or automatically. Manual mode can be used for cleaning the rear spoiler when the vehicle is stationary, for example.

The rear spoiler remains in the last mode in each case after a terminal change.



G32 Rear spoiler button

G32 Complete Vehicle

2. Body

Index	Explanation
1	Rear spoiler button

Manual mode

- **Touch the rear spoiler button**
 - The indicator light in the rear spoiler button lights up.
 - The rear spoiler extends when stationary or at a driving speed < 110 km/h (< 68 mph).
- **Driving speed < 20 km/h (< 12 mph):** Press and hold down the rear spoiler button
 - The rear spoiler retracts as long as the rear spoiler button is pressed. If the button is released before the rear spoiler is fully retracted, the rear spoiler is fully extended again.
 - If the rear spoiler is fully retracted, the indicator light in the rear spoiler button goes out.

Automatic mode

- Driving speed > 110 km/h (> 68 mph): Rear spoiler extends automatically.
- Driving speed < 70 km/h (< 43 mph): Rear spoiler retracts automatically.

2.7.5. Notes for Service

Speed limits

Speed	Designation	Comment
20 km/h (12 mph)	Constant pressure	The button must be pressed continuously for manual retraction below this speed threshold. The speed threshold is also used for automatic retraction of the rear spoiler in the event of a fault.
70 km/h (43 mph)	Retract rear spoiler	At or below this speed limit the rear spoiler retracts again in Automatic mode.
110 km/h (68 mph)	Extend rear spoiler	The rear spoiler extends from this speed limit.
130 km/h (80 mph)	Continuous gong in the event of fault	As from this speed threshold, an acoustic warning signal sounds for 90 s in the event of a fault in the rear spoiler.

G32 Complete Vehicle

2. Body

Check control message

Malfunctions of the rear spoiler are indicated by a Check Control message:

Check Control symbol	Check control message	Note
	Rear spoiler	Rear spoiler faulty. Do not drive faster than 130 km/h (80 mph).

In addition to the Check Control message shown above, an acoustic information signal sounds once. A continuous acoustic signal sounds for 90 s as from a driving speed of 130 km/h (80 mph).

A malfunction is detected in the event of the following faults:

- If more than 5 seconds elapse between the signals “Extend rear spoiler” and “Rear spoiler extended”.
- Interruption of the signal “Rear spoiler extended”.
- Sensor fault “Rear spoiler extended”.
- Rear spoiler cannot be extended (e.g. iced up).

In the event of a rear spoiler malfunction, the Dynamic Stability Control (DSC) will be switched back on again if this has been switched off.



The tailgate and spindle drives can be damaged if the tailgate is operated when the rear spoiler has been removed. The tailgate must be held down in this case, since it will otherwise move up very quickly due to the lacking weight.

2.8. Luggage compartment

The luggage compartment capacity has increased in comparison with the F07.



G32 Complete Vehicle

2. Body

Luggage compartment	G32	F07
Luggage compartment volume	610 liters	590 liters
Luggage compartment capacity with rear seat backrests folded down	1800 liters	1700 liters

2.9. Interior equipment

2.9.1. Overview

The following graphic shows the operating area of the G32. The operating area of the G32 is based on that of the G30. Further information is provided in: **ST1604 G30 Display and Controls**.



G32 driving area

TG17-1020

G32 Complete Vehicle

2. Body

2.9.2. Seat bench

The rear seat backrests can be folded down in a ratio of 40:20:40. The standard equipment already includes electrical unlocking of the rear seat backrests.



G32 seat bench

2.9.3. Backrest remote unlocking

The rear seat backrests are electrically unlocked. Buttons are installed on the rear seat backrests and in the luggage compartment for this purpose. The left and middle rear seat backrests are folded down by means of the left-hand buttons and the right rear seat backrest by means of the right-hand buttons.

G32 Complete Vehicle

2. Body

Rear seat operation



G32 Button for rear seat backrest release

Luggage compartment operation



G32 Buttons for backrest remote unlocking in luggage compartment

G32 Complete Vehicle

2. Body

System wiring diagram

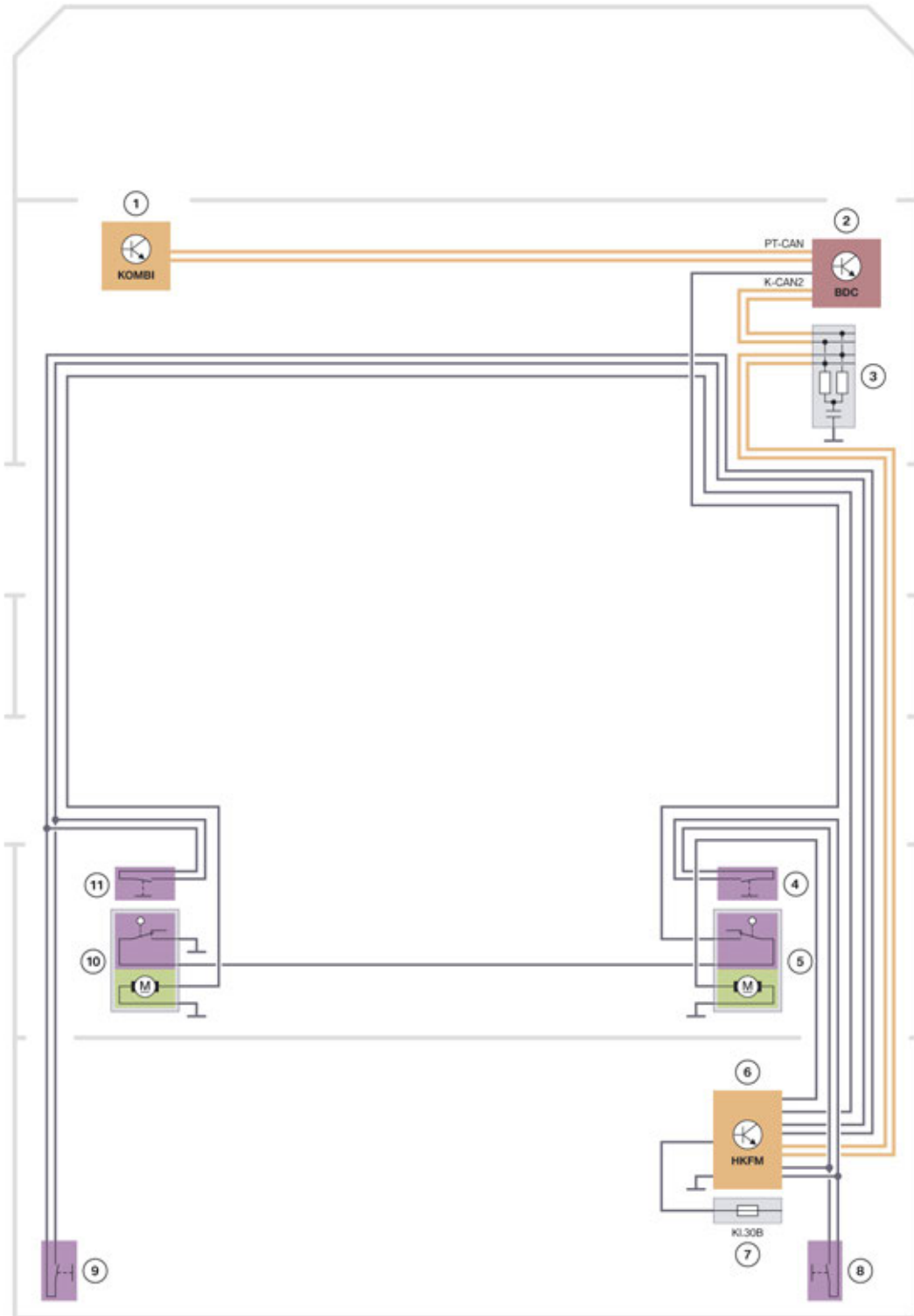

TE17-0757

G32 Backrest remote unlocking

G32 Complete Vehicle

2. Body

Index	Explanation
1	Instrument cluster (KOMBI)
2	Body Domain Controller (BDC)
3	CAN terminator
4	Switch for backrest remote unlocking, rear seat right
5	Electric motor for backrest remote unlocking, right
6	Tailgate function module (HKFM)
7	Luggage compartment power distribution box fuse
8	Switch for backrest remote unlocking in luggage compartment, right
9	Switch for backrest remote unlocking in luggage compartment, left
10	Electric motor for backrest remote unlocking, left
11	Switch for backrest remote unlocking, rear seat left

G32 Complete Vehicle

2. Body

2.9.4. Backrest adjustment

The backrests of the seat bench can be electrically adjusted. The backrest can be adjusted by means of a button installed on the side of the seat bench. Adjustment is done by an electric motor which is connected with the striker.

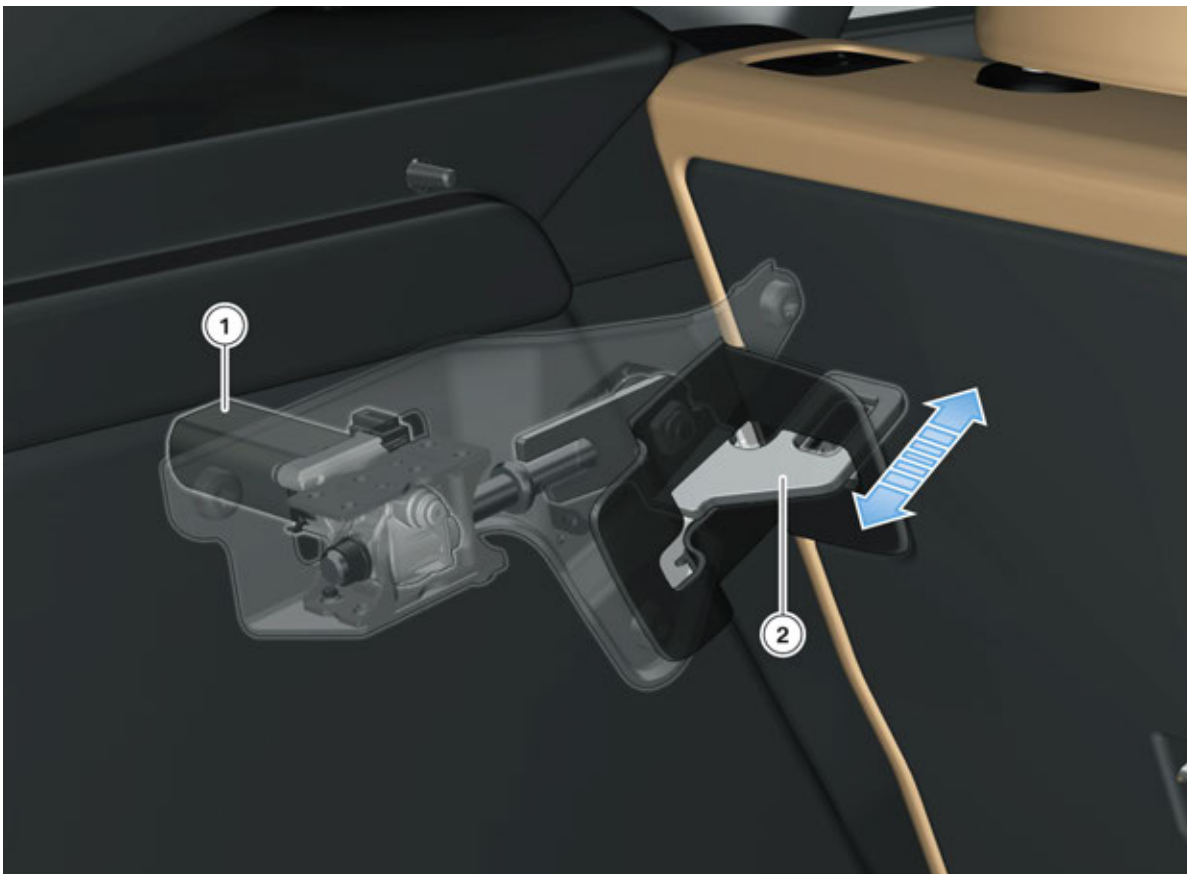

G32 Adjustment of rear seat backrests

Index	Explanation
1	Electric motor
2	Striker

G32 Complete Vehicle

3. Powertrain

3.1. Engine

The following contains an overview of the engine used in the G32:

3.1.1. Gasoline

Model	Engine	[kW] (hp)	[Nm] (lb-ft)
BMW 640i xDrive	B58B30M0	250 (335)	450 (332)

3.2. Transmission

The G32 is already equipped as standard with the 8-speed automatic transmission familiar from other vehicles. The following table shows the transmission variant installed:

Model	Transmission
BMW 640i xDrive	GA8HP50

A Steptronic sport transmission is standard equipment. The following features are included:

- Manual gearshifts via shift paddles on the steering wheel
- Launch Control
- SPORT+ mode

G32 Complete Vehicle

4. Chassis and Suspension

4.1. Standard equipment

In the standard equipment configuration, the G32 has single-axle ride level control on the rear axle and conventional shock absorbers with steel springs on the front axle. An Electronic Power Steering system is installed for steering.



TE17-0745

G32 Chassis and suspension standard equipment

Index	Explanation
1	Electronic Power Steering
2	Front shock absorber with steel spring
3	Air spring, rear axle

4.2. Optional equipment

The following optional equipment is available for the G32 in the area of the chassis and suspension:

- Integral Active Steering (OE 2VH)
- Adaptive Drive + 2-axle air suspension (OE 2VT)
These features are included in the Dynamic Handling Package (ZDH).

G32 Complete Vehicle

4. Chassis and Suspension

4.2.1. Integral Active Steering

The Integral Active Steering includes variable rack geometry for the steering and rear axle slip angle control.



TE17-0744

G32 Integral Active Steering

Index	Explanation
1	Electronic Power Steering
2	Front shock absorber with steel spring
3	Air spring, rear axle
4	Rear axle slip angle control

4.2.2. Adaptive Drive + 2-axle air suspension

An air suspension can be ordered for the front and rear axles as optional equipment. Shock absorbers with Dynamic Damper Control are installed in combination with the two-axle ride level control.

The ride height of the vehicle can be adjusted by means of a button in the Center console. The two-axle ride level control is already familiar from the G12.

This option is included in the Dynamic Handling Package (ZDH).

G32 Complete Vehicle

4. Chassis and Suspension



TE17-0746

G32 Adaptive two-axle ride level control

Index	Explanation
1	Electronic Power Steering
2	Air spring on front axle with Dynamic Damper Control
3	Air spring on rear axle with Dynamic Damper Control

4.2.3. Active Roll Stabilization

The electric active stabilizers are installed on the front and rear axles EARSV/EARSH.

This option is included in the Dynamic Handling Package (ZDH).

G32 Complete Vehicle

4. Chassis and Suspension

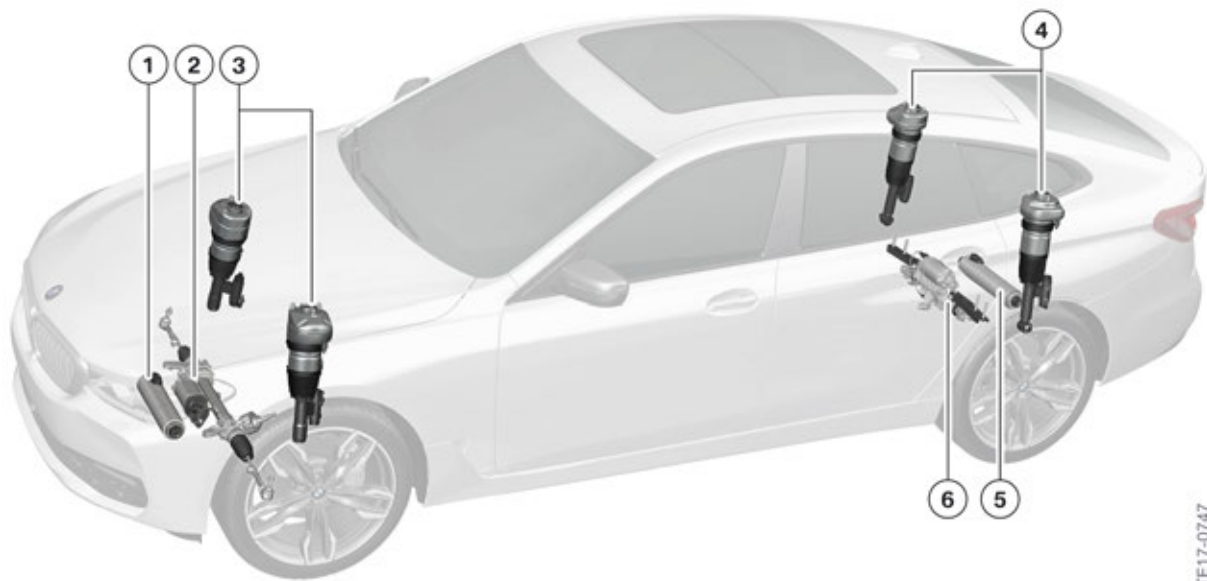

TE17-0747

G32 Executive Drive

Index	Explanation
1	Electronic Power Steering
2	Air spring on front axle with Dynamic Damper Control
3	Electric active roll stabilization front
4	Electric active roll stabilization rear
5	Rear axle slip angle control
6	Air spring on rear axle with Dynamic Damper Control

4.3. Further information

The following product information documents contain further information on the individual systems/ components:

System/component	Product information
Integral Active Steering	ST1501 G12 Chassis and Suspension
Two-axle ride level control	ST1501 G12 Chassis and Suspension
Electric active roll stabilization	ST1501 G12 Chassis and Suspension

G32 Complete Vehicle

5. General Vehicle Electronics

5.1. Bus overview

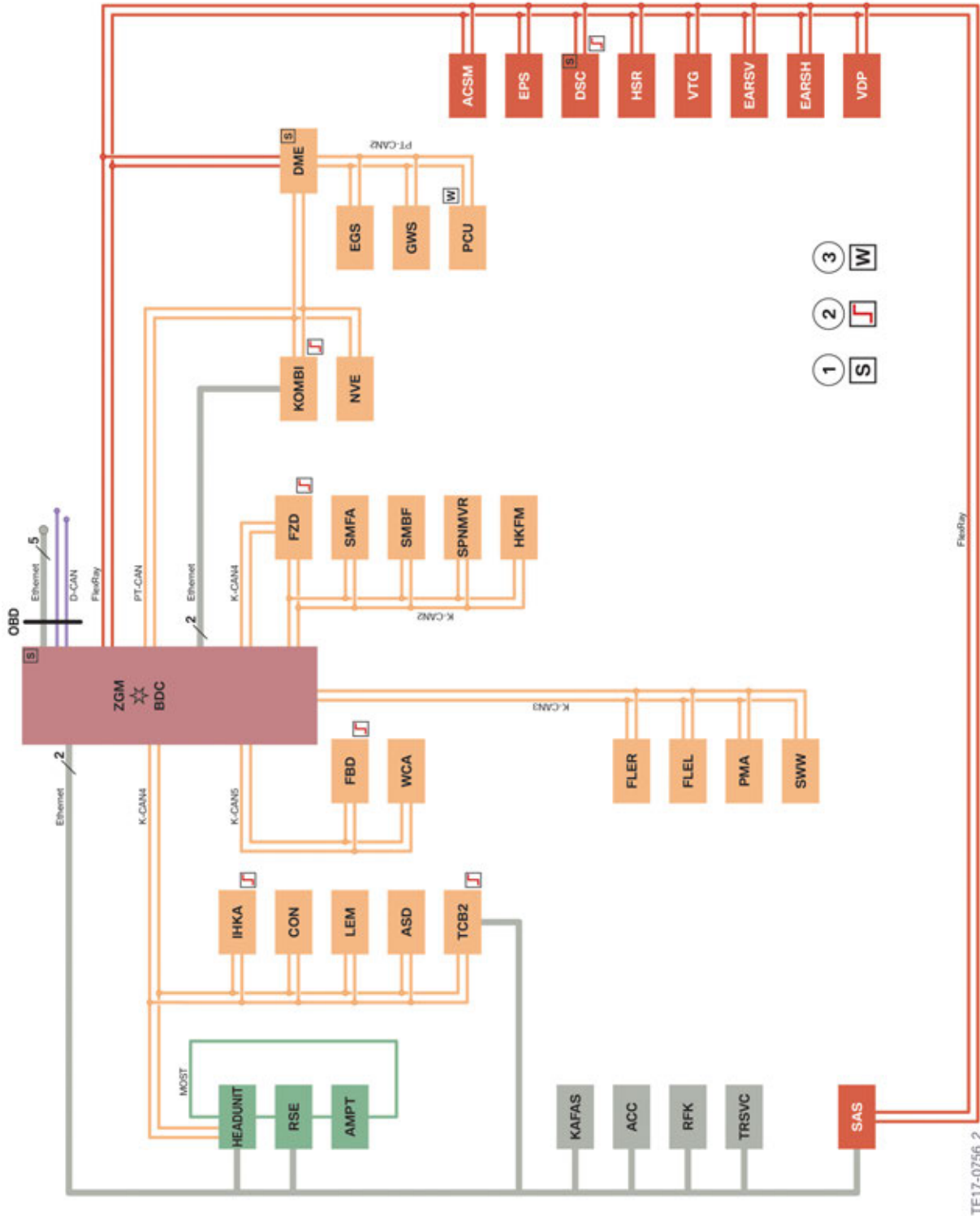

G32 bus overview

G32 Complete Vehicle

5. General Vehicle Electronics

Index	Explanation
1	Control units which synchronize the FlexRay
2	Control units with wake-up authorization
3	Control units which are connected to the wake-up line
ACC	Active Cruse Control
ACSM	Advanced Crash Safety Module
AMPT	Top HiFi amplifier
ASD	Active Sound Design
BDC	Body Domain Controller
CON	Controller
DME	Digital Motor Electronics
DSC	Dynamic Stability Control
EARSH	Electric active roll stabilization rear
EARSV	Electric active roll stabilization front
EGS	Electronic transmission control
EPS	Electronic Power Steering
FBD	Remote control receiver
FLEL	Frontal Light Electronics Left
FLER	Frontal Light Electronics Right
FZD	Roof function center
GWS	Gear selector
HEADUNIT	Head unit
HKFM	Tailgate function module
HSR	Rear axle slip angle control
IHKA	Integrated automatic heating / air conditioning
KAFAS	Camera-based driver support systems
KOMBI	Instrument panel
LEM	Light Effect Manager
NVE	Night Vision Electronics
PCU	Power Control Unit
PMA	Parking Manoeuvring Assistant
RFK	Rear view camera
RSE	Rear Seat Entertainment
SAS	Optional equipment system
SMBF	Seat module, passenger
SMFA	Seat module, driver

G32 Complete Vehicle

5. General Vehicle Electronics

Index	Explanation
SPNMVR	Seat pneumatics module front right
SWW	Lane change warning
TCB2	Telematic Communication Box 2
TRSVC	Top rear side view camera
WCA	Wireless charging station
VDP	Vertical dynamic platform
VTG	Transfer box
ZGM	Central gateway module

5.2. Exterior lights

5.2.1. Headlights

The G32 already comes with Icon Adaptive Full LED headlights as standard equipment.



G32 Headlight

Further information on the LED headlights is provided in the product information **ST1604 G30 General Vehicle Electronics**.

5.2.2. Rear lights

The rear lights feature three-dimensional notching in order to highlight the light form.

All lighting functions of the rear lights are LEDs.

The following graphic shows the positions of the lighting functions:

G32 Complete Vehicle

5. General Vehicle Electronics

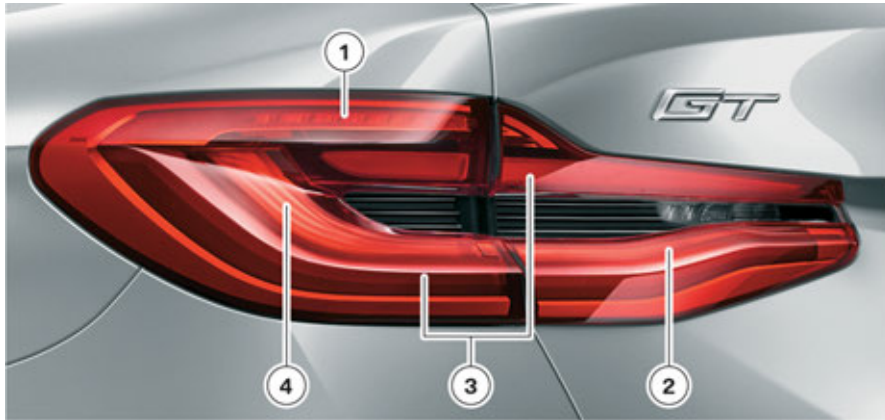

G32 Rear light

Index	Explanation
1	Brake light
2	Reversing light
3	Tail light
4	Turn indicator

5.2.3. Light carpet

In combination with the Ambiance Lighting option (OE 4UR), the G32, like the G12 previously, also has a light carpet function in addition to the ground lighting in the door handles. The light carpet is activated when the vehicle is unlocked. The light source is installed in the side sills on the left and right.



G32 Light carpet

Further information on the light carpet is provided in the product information **ST1501 G12 General Vehicle Electronics**.

G32 Complete Vehicle

5. General Vehicle Electronics

5.3. Shared features with the G30

The following table provides an overview of the product information in which you will find further information regarding the general vehicle electrical system:

System	Product information
Infotainment	<ul style="list-style-type: none">• ST1604 G30 Infotainment• ST1604 G30 Navigation Systems• ST1604 G30 Telephone and Telematics
Voltage supply	<ul style="list-style-type: none">• ST1604 G30 Voltage Supply & Bus Systems
Heating and air conditioning system	<ul style="list-style-type: none">• ST1604 G30 Climate Control
Vehicle electrical system	<ul style="list-style-type: none">• ST1604 G30 General Vehicle Electronics
Displays and Controls	<ul style="list-style-type: none">• ST1604 G30 Displays and Controls

G32 Complete Vehicle

6. Driver Assistance Systems

6.1. Overview

The assistance systems of the G32 are identical with those of a G30. This product information shows only an overview of the available assistance systems and packages. Further information on the assistance systems is provided in the product information **ST1604 G30 Driver Assistance Systems**.

The following assistance systems are available for the G32:

- Park Distance Control (PDC), front and rear (standard equipment)
- Rear view camera (standard equipment)
- High-beam assistant (standard equipment)
- Night Vision (OE 6UK)
- Active Driving Assistant (standard equipment)
- Active Driving Assistant Plus (OE 5AT)
- Active Cruise Control (OE 5DF)
- Parking Assistant Plus (OE 5DN) included in the Parking Assistance Package ZPK or the Executive Package ZPL.

G32 Complete Vehicle

6. Driver Assistance Systems

6.2. Sensors

The following graphic shows the sensors of the assistance systems:

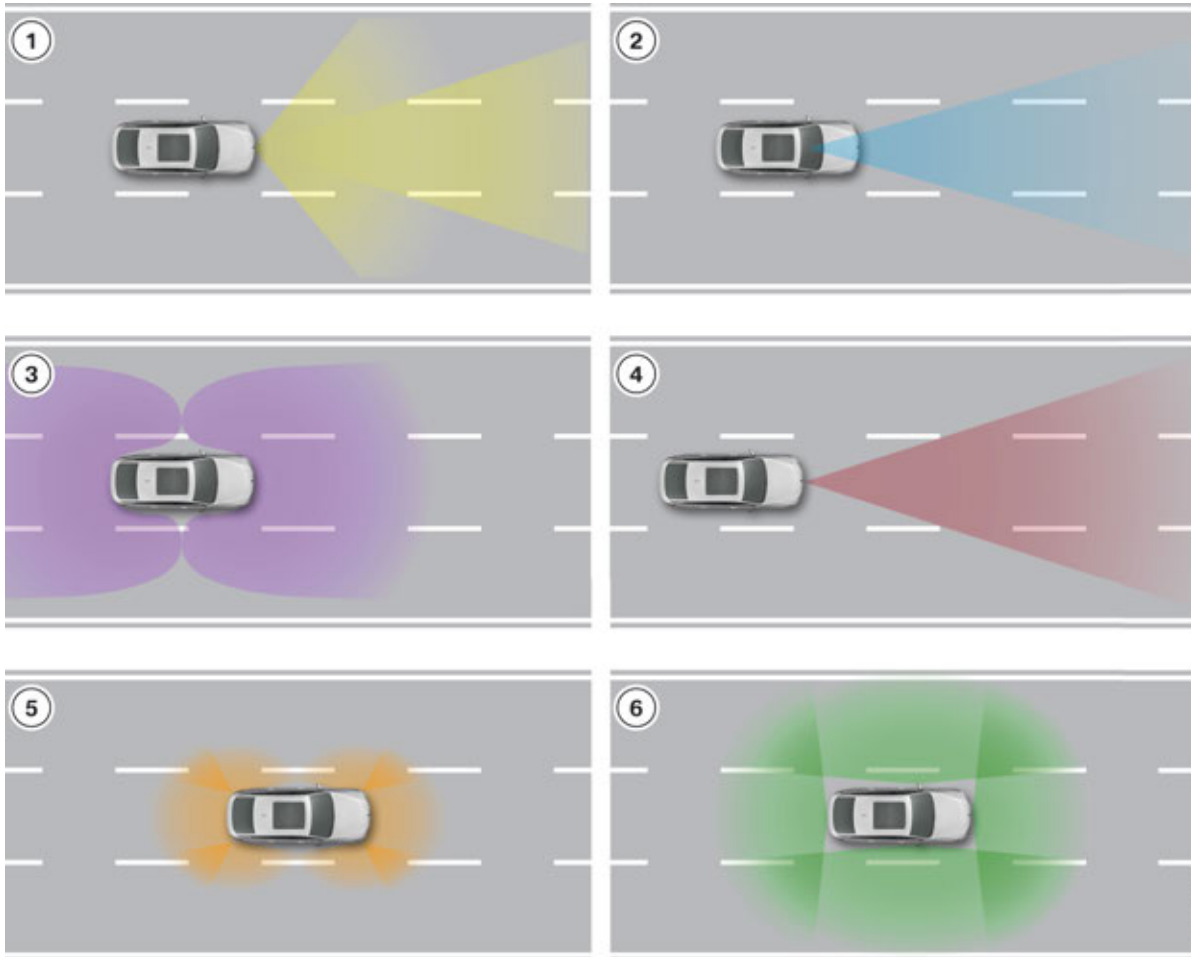

G32 Assistance system sensors

Index	Explanation
1	Radar sensor for active cruise control
2	KAFAS stereo camera
3	Radar sensors
4	Night vision
5	Ultrasonic sensors
6	Camera systems

G32 Complete Vehicle

6. Driver Assistance Systems

6.3. Package overview

6.3.1. Active Driving Assistant

The Driving Assistant contains the following assistance systems:

- Active Blind Spot Detection
- Lane Departure Warning
- Frontal Collision Warning w/City Collision Mitigation
- Daytime Pedestrian Protection
- Cross Traffic Alert Rear
- Speed Limit Info

6.3.2. Driving Assistant Plus

The optional equipment Driving Assistant Plus (OE 5AT) includes the following assistance systems:

- Active Driving Assistant
- Active Cruise Control with Stop&Go Function
- Traffic Jam Assistant
- Active Lane Keeping Assistant with Active Side Collision Avoidance
- Cross Traffic Alert Front
- Evasion Aid

The lane change assistant is not offered in the G32.

6.3.3. Parking Assistant Package

The following assistance systems are included in the Parking Assistant Package (ZPK) optional equipment:

- Parking Assistant Plus
- Active Park Distance Control
- Surround View w/ 3D Camera

G32 Complete Vehicle

7. Infotainment

7.1. Speaker systems

The G32 comes with 3 different sound systems, depending on equipment. The following table provides an overview of the individual systems:

Speaker system	Total output power in watts	No. of speakers
Hi-fi system (Standard)	205 W	<ul style="list-style-type: none">Total: 12Tweeters: 5Mid-range speakers: 5Bass speakers: 2
Harman Kardon Surround Sound System (OE 688)	600 W	<ul style="list-style-type: none">Total: 16Tweeters: 7Mid-range speakers: 7Bass speakers: 2
Bowers & Wilkins Diamond Surround Sound System (OE 6F1)	1400 W	<ul style="list-style-type: none">Total: 16Tweeters: 7Mid-range speakers: 7Bass speakers: 2

7.2. Telephone systems

Convenient telephony with enhanced smartphone connection with wireless charging is standard equipment.

The following table provides an overview of the available telephone systems of the G32 and their special features:

System	Snap-in adapter	External Antenna	USB interfaces
Telephony with wireless charging (Standard)	No	Yes	2 (2.1 A charge current)

G32 Complete Vehicle

7. Infotainment

The wireless charging station is located in the front center console.



G32 Wireless charging station

7.3. Accident Assistance

7.3.1. Function

The BMW Teleservice Accident Assistance is a new ConnectedDrive service. The vehicle detects accidents in the lower speed range and displays a warning message in the central information display and instrument cluster. The driver can start the service and a connection is established to the BMW Call Center. The employee in the BMW Call Center can advise the driver and if necessary also organize a tow recovery service for transport of the vehicle to the nearest BMW Service location.



Procedure for Accident Assistance

Index	Explanation
1	Vehicle detects accident in the lower speed range
2	Warning message in the central information display
3	Connection with the BMW Call Center
4	Vehicle repair

The system detects accidents below the airbag trigger threshold and then displays the Accident Assistance service, which can be started by the driver via a link. A 5th generation ACSM is a prerequisite for the service.

G32 Complete Vehicle

7. Infotainment

7.3.2. Requirement

BMW Teleservices (standard equipment) are a prerequisite for the Accident Assistance function.

Accident Assistance will be launched with G series vehicles as from the production date 07/2017:

It is possible to display in the ConnectedDrive Service Cockpit whether the Accident Assistance service is available.

7.3.3. Displays

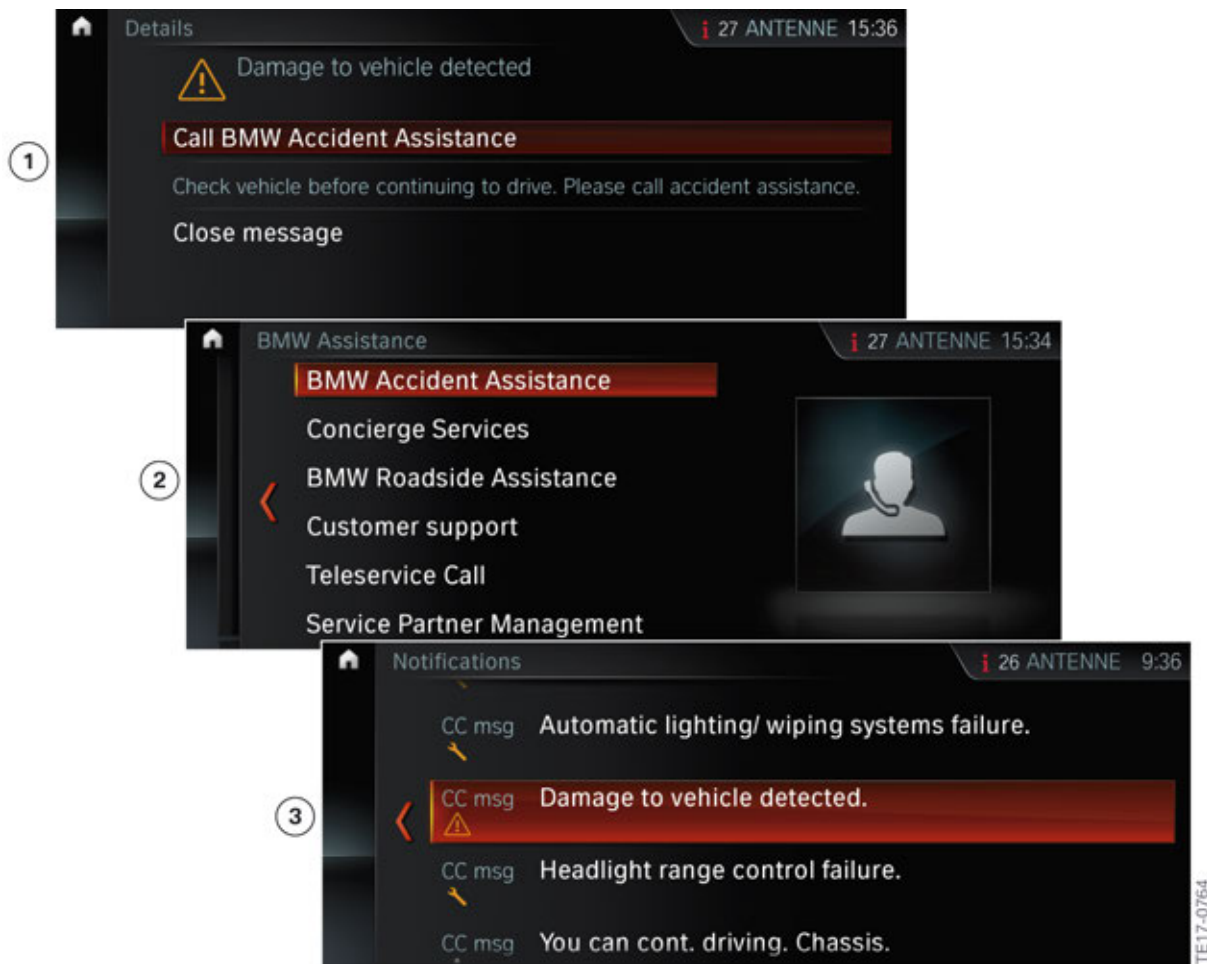

Warning messages for Accident Assistance on central information display

Index	Explanation
1	Accident Assistance warning message after a detected accident. A connection is established to the BMW Call Center by a confirmation.
2	Accident Assistance service in the ConnectedDrive menu
3	Check Control message for detected Accident Assistance

G32 Complete Vehicle

7. Infotainment

7.4. Antenna

7.4.1. Overview

The following table contains an overview of the antennas used in the G32:

Antenna	Installation location
FM1/FM2/AM	Lower
SDARS	Lower
WLAN hotspot	Telematic Communication Box 2 (TCB2)
Vehicle WLAN	Antenna, left side sill
Bluetooth	Antenna, center console
Telephone TEL1 wireless charging station	Roof Antenna
Telephone TEL2 telematics services	Roof Antenna
GPS Antenna	Roof Antenna

G32 Complete Vehicle

7. Infotainment

7.4.2. System wiring diagram

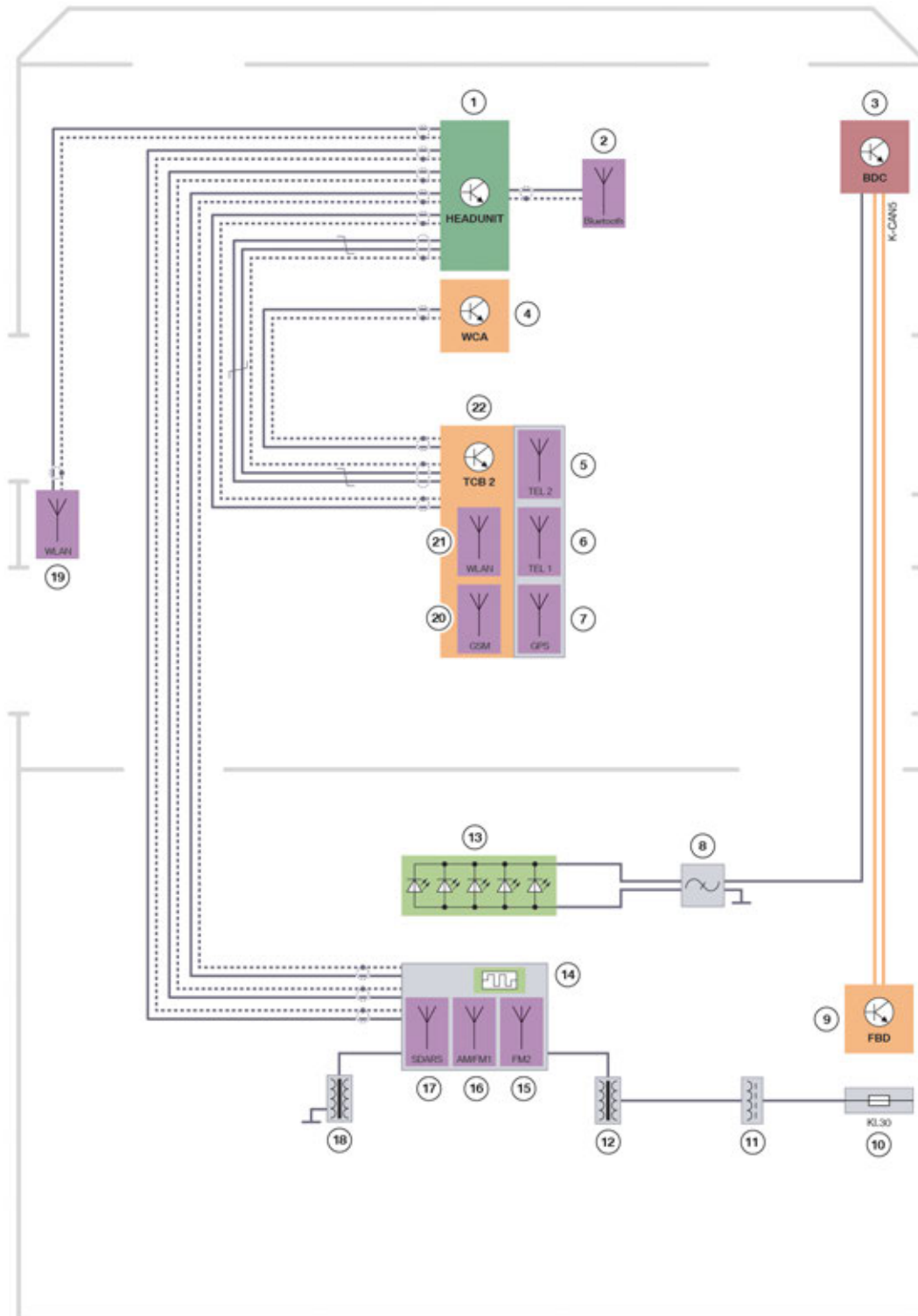

TE17-0758.2

G32 Antenna

G32 Complete Vehicle

7. Infotainment

Index	Explanation
1	Head unit
2	Bluetooth antenna
3	Body Domain Controller (BDC)
4	Wireless charging station
5	Antenna TEL2 (telematics services)
6	Antenna TEL1 (telephone with wireless charging)
7	GPS antenna
8	Interference suppression filter
9	Remote control receiver (FBD)
10	Luggage compartment power distribution box fuse
11	Wave trap
12	Signal booster
13	Additional brake light
14	Lower grid
15	FM2 antenna
16	AM/FM1 antenna
17	SDARS antenna
18	Signal booster
19	Vehicle WLAN antenna
20	GSM Antenna for emergency
21	WLAN hotspot antenna
22	Telematic Communication Box 2 (TCB2)



Bayerische Motorenwerke Aktiengesellschaft
Händlerqualifizierung und Training
Röntgenstraße 7
85716 Unterschleißheim, Germany