

Reference Manual



F80 / F82 COMPLETE VEHICLE



Technical Training

The information contained in this manual is not to be resold, bartered, copied or transferred without the express written consent of BMW of North America, LLC ("BMW NA").

Technical training.
Product information.

F80/F82 Complete Vehicle



BMW Service

Edited for the U.S. market by:
BMW Group University
Technical Training

ST1402

11/1/2014

General information

Symbols used

The following symbol/schematic diagram is used in this document to facilitate better comprehension or to highlight very important information:



Contains important safety information and information that needs to be observed strictly in order to guarantee the smooth operation of the system.

Information status and national-market versions

BMW Group vehicles meet the requirements of the highest safety and quality standards. Changes in requirements for environmental protection, customer benefits and design render necessary continuous development of systems and components. Consequently, there may be discrepancies between the contents of this document and the vehicles available in the training course.

This document basically relates to the European version of left-hand drive vehicles. Some operating elements or components are arranged differently in right-hand drive vehicles than shown in the graphics in this document. Further differences may arise as a result of the equipment specification in specific markets or countries.

Additional sources of information

Further information on the individual topics can be found in the following:

- Owner's Manual
- Integrated Service Technical Application.

Contact: conceptinfo@bmw.de

©2014 BMW AG, Munich

Reprints of this publication or its parts require the written approval of BMW AG, Munich

The information contained in this document forms an integral part of the technical training of the BMW Group and is intended for the trainer and participants in the seminar. Refer to the latest relevant information systems of the BMW Group for any changes/additions to the technical data.

Information status: **March 2014**
BV-72/Technical Training

F80/F82 Complete Vehicle

Contents

1. Introduction	1
1.1. M history	2
1.1.1. E30 M3	2
1.1.2. E36 M3	4
1.1.3. E46 M3	6
1.1.4. E90/E92/E93 M3	8
1.2. F80 M3 vehicle profile	10
1.3. F82 M4 Coupe vehicle profile	11
2. Technical Data	13
2.1. Garage dimensions	13
2.2. Comparison of technical data in BMW	14
2.2.1. BMW EfficientDynamics measures	16
2.3. BMW M3 and M4 Coupe compared to competitors	17
2.3.1. M3	17
2.3.2. M4 Coupe	18
3. Body	19
3.1. Bodyshell	19
3.1.1. Chassis and suspension components and rigidity concept	19
3.2. Exterior	21
3.2.1. Front view	21
3.2.2. Side view	23
3.2.3. Rear quarter panel and rear view	27
3.2.4. Trunk lid	28
3.2.5. Underbody and thermal protection	29
3.3. Interior	30
3.3.1. Driving area and steering wheel	30
3.3.2. Leather trim	31
3.3.3. Seats	32
3.3.4. Doors and decorative strips	33
4. Powertrain	34
4.1. Engine S55B30T0	34
4.2. Transmission	34
4.2.1. Manual gearbox	34
4.2.2. Clutch	36
4.2.3. M double-clutch transmission (M DCT) with Drivelogic	36
4.2.4. Structure and power flow	38
4.2.5. Technical data of M DCT	43
4.2.6. System information	44

F80/F82 Complete Vehicle

Contents

4.2.7.	M gear selector switch.....	47
4.2.8.	Drivelogic.....	47
4.2.9.	Launch Control.....	48
4.2.10.	Transmission control unit.....	49
4.2.11.	Emergency gearbox release.....	49
4.2.12.	Service information.....	50
4.3.	Driveshaft.....	51
4.3.1.	Service information.....	52
4.4.	Rear axle final drive.....	52
4.4.1.	Active M Differential	52
4.4.2.	Structure/Function.....	54
4.4.3.	System information.....	57
4.4.4.	Service information.....	60
4.4.5.	Half-shafts.....	61
4.4.6.	Wheel flange.....	62
5.	Chassis and Suspension.....	63
5.1.	Front Axle.....	64
5.1.1.	Steering.....	67
5.1.2.	Servotronic.....	69
5.1.3.	Steering angle sensor.....	70
5.1.4.	System wiring diagram, M Servotronic (EPS).....	71
5.2.	Rear axle.....	72
5.3.	Brakes and wheels/tires.....	75
5.3.1.	Brakes.....	75
5.3.2.	Wheels/tires.....	79
5.4.	Dynamic handling control systems.....	80
5.4.1.	Vertical Dynamics Management.....	80
5.4.2.	Transverse dynamics management	85
5.4.3.	Longitudinal dynamics management	85
6.	General Vehicle Electronics.....	86
6.1.	Voltage supply.....	86
6.1.1.	Overview.....	86
6.1.2.	Advantages.....	86
6.1.3.	Comparison of li-ion starter battery/lead starter battery.....	87
6.1.4.	Structure of the li-ion starter battery.....	88
6.1.5.	Function.....	90
6.1.6.	Actions in the event of a fault.....	91
6.1.7.	System wiring diagram.....	94

F80/F82 Complete Vehicle

Contents

6.1.8.	Li-ion starter battery in Service.....	95
6.2.	Bus overview	97
6.3.	On-board information.....	100
6.3.1.	MDrive menu.....	100
6.3.2.	M instrument cluster.....	103
6.3.3.	Head-Up Display.....	104
6.3.4.	Active Sound Design	105
6.3.5.	M Lap Timer app	105
7.	Brief Overview of Equipment.....	106
7.1.	F80/F82 standard equipment.....	106
7.1.1.	Paint colors.....	106
7.1.2.	Leather colors.....	107
7.1.3.	Interior trims.....	107

F80/F82 Complete Vehicle

1. Introduction

The BMW M brand is expanding. In addition to the current BMW M models (the 5-Series, 6-Series and X models), for the first time there is also a BMW M4 Coupe with the introduction of the fifth generation of the new BMW M3 .

Similar to all BMW AG vehicles, the BMW M Coupe and the M Convertible body variants will also be marketed as a BMW 4-Series in order to clearly distinguish this segment from the Sedans.

The "4" in the type plate is a visual indicator of how different the new BMW M4 Coupe is to the BMW M3 4 door Sedan with its own personality, enhanced sporting character and more exclusivity.

The new BMW M4 Coupe and the new BMW M3 in the fifth generation were systematically designed for lightweight construction. In order to achieve this objective, this lightweight construction concept was consistently applied in the body area, as well as in the powertrain and chassis and suspension. A composite construction with different material combinations is used in the body, electrical system, in the chassis and suspension and the powertrain. Metals such as steel, magnesium and aluminum, as well as the use of plastics and fiber composites, are used alternately.

In contrast to the predecessor where a high-speed 8-cylinder naturally aspirated engine was used, for the first time in the BMW M3/M4 Coupe an engine with six cylinders and turbocharging is used as a powertrain.

In the area of the powertrain concept, the BMW M3 and the BMW M4 Coupe thus pursue the same strategy as their big brother in the BMW M X-Series, as well as that of the BMW M5/M6, where turbocharged engines have been in use for a long time.

This combination of consistent lightweight construction and turbocharging guarantees that power and agility are exceptional and enhances the competitive position of the BMW M3 and BMW M4 Coupe.

With success embedded in the genes, the new BMW M4 Coupe and the new BMW M3 in the fifth generation will celebrate their global premier in June 2014.

F80/F82 Complete Vehicle

1. Introduction

1.1. M history

1.1.1. E30 M3

It all started with the first M3, launched as a thoroughbred sports car for the road. Roughly 18,000 vehicles, Coupe and Convertible. Two four-cylinder four-valve engines were available worldwide. It was produced between 1986 - 1991 (1988 - 1991 in the US market), the first M3 generation turned the world of racing upside down. The original M3 also showed its sporting ambitions in its exterior design. The flared wheel arches and a large rear spoiler gave it a massive road presence.



E30 M3

1986

The E30 M3 celebrates its debut with a 4-cylinder engine (S14B23) and 194/200 HP with/without catalytic converter.

1987

The M3 dominates the touring car races worldwide. Roberto Ravaglia brings the championship title back to Munich. The limited edition Evo I with 200 HP (S14B23) is here.

1988

The popular Evo II now has 220 HP (S14B23). Those who like to go "topless" can choose the M3 convertible.

F80/F82 Complete Vehicle

1. Introduction

1989

The M3 wins 16 national and European titles, including the European Hill-Climbing Championship for Touring Cars. The special edition Cecotto with 215 HP (S14B23) makes its debut.



E30 M3 Cecotto

1990

The M3 wins 15 national and international championships. The limited quantity of the Evo II with catalytic converter and 238 HP (S14B25) is sold out quickly.

F80/F82 Complete Vehicle

1. Introduction

1.1.2. E36 M3

Over 70,000 vehicles, Coupe, Convertible and 4 door Sedan are mass produced. The Z3 M Roadster and Z3 M Coupe are not included. There was the M3 with two different engines and vehicle versions, a US version and a European version.

In the US market it was produced in two versions the first in 1995 and the later between 1996-2000. The second-generation M3 was offered as a complete model series. First came the Coupe and two years later the Convertible and Sedan. And the engine received a nice boost, too: The four-valve six-cylinder engine delivered 240 hp.



E36 M3 as 4 door Sedan, Coupe and convertible

1992

The second M3 generation, the E36 M3 with a 6-cylinder engine and 286 HP (S50B30/US S52B30 with 240 HP), attracts a great deal of attention, the individual version celebrates its global première at the Geneva Motor Show.

For the first time, the high pressure VANOS (single VANOS) is used in a M engine.

1993

The E36 M3 is now also available as a convertible.

1994

Steve Soper, Joachim Winkelhock and Jonny Cecotto win the touring car world championship title. For the first time, a 4-door Sedan is also offered with the E36 M3. The type approval series of the M3 GT (only Coupe) which has 295 HP (S50B30) is developed.

F80/F82 Complete Vehicle

1. Introduction

1995

The E36 M3 in the European version has been completely revised. It now has, for example, a compound brake with brake discs made from a combination of materials and a high pressure double VANOS, whereby the engine (S50B32) develops 321 HP. (US version S52B32 still with 240 HP). It is only offered as a Coupe and convertible.

1996

The E36 M3 is available with a sequential M gearbox (SMG I).



SMG I in the E36 M3

F80/F82 Complete Vehicle

1. Introduction

1.1.3. E46 M3

The E46 M3 was available in a Coupe and Convertible version. Over 80,000 vehicles were produced. There was one engine worldwide.

In the US market it was produced between 2001 and 2006, the third generation of the M3 enters the stage with the M3 Coupe and the high-revving naturally aspirated S54 engine delivering 333 hp at up to 7,900 rpm. BMW once more introduced a true sports car, which, like its predecessor, was crowned "best handling car". From 2001, BMW added the convertible version.



E46 M3

2000

The third generation, the E46 M3, has a 6-cylinder engine with a high-speed concept and 343 HP (S54B32). This first M engine with "high-speed concept" impresses the experts and is awarded "Engine of the Year". The M3 is the first M vehicle to receive the fully variable M differential lock with up to 100 percent locking action as standard.

2001

The M3 convertible combines the fascination of the M power with "topless" driving pleasure. The sequential M gearbox of the second generation (SMG II) is available.

F80/F82 Complete Vehicle

1. Introduction

2002

With the M3 CSL with 360 HP (S54B32HP), the BMW M shows how a high-powered vehicle can be further enhanced through the use of lightweight construction materials in an intelligent lightweight construction. For the first time, the M track mode (today called M dynamic mode), the SMG launch control (automatic upshift in S mode shortly before maximum speed) and an oil level check are used.



E46 M3 CSL

F80/F82 Complete Vehicle

1. Introduction

1.1.4. E90/E92/E93 M3

The Coupe was launched in 2007, followed by the 4 door Sedan and convertible with about 70,000 vehicles produced up until January 2014.

The E9x BMW M3 had a F1 inspired naturally aspirated V8 engine, suspension and drivetrain, a convincing design and best-in-class performance, the latest generation of the BMW M3 is once again making headlines. As with all M vehicles, BMW delivers a true sports car with fantastic everyday usability. The fourth generation BMW M3 was available across the E9X model line up, as E92 Coupe, E90 Sedan or as a Convertible with the E93. This M3 features the successor of SMG III the M-DCT (M Double-Clutch Transmission with Drivelogic).



E92 M3

2007

The fourth generation of the M3 comes in 2007 as a Coupe E92 and at the end of 2007 as a Sedan E90 with the high-speed S65B40 engine with 420 HP (414 HP and 295 lb-ft in the US).

2008

The E93 M3 (convertible version) was introduced. For the first time in the history of BMW, a M DKG (M-DCT I) is also used, which allows a gear change without tensile force interruption and replaces the sequential M gearbox.

Over a quarter of a century and five generations of BMW M3: The sportiest 3-Series as E9x celebrated its 25th birthday in 2010.

F80/F82 Complete Vehicle

1. Introduction

2010

As low volume production for customers who take part in club sport events, BMW M GmbH offers the M3 GTS. The sporty vehicle underwent modifications in the powertrain and chassis and suspension, as well as in the interior equipment and the body, in order to meet the requirements in club sports. The power of the high-speed S65B44 was raised to 450 HP. This vehicle was not available in the US market.



TG10-0269

E92 M3 GTS

F80/F82 Complete Vehicle

1. Introduction

1.2. F80 M3 vehicle profile



F80 M3

- **Design and aerodynamics:** Four-door high-speed Sedan with M-specific characteristics. Consistent lightweight construction in the entire body with clever aerodynamic design at the front, side and rear areas as well as in the vehicle underbody.
- **Engine/Transmission:** 3-liter 6-cylinder engine Turbo-Valvetronic direct injection engine. Enhanced efficiency, while delivering even more power than the previous engine with regard to spontaneous linear power development. Choice of three engine dynamics control programs. Electronically controlled M rear-axle differential lock is standard equipment. The M Double-clutch Transmission with Drivelogic (M DTC) is available as an option. The consistent lightweight construction concept also extends to the design of the powertrain.
- **Engine sound:** Adds a Sporty character in the lower and upper engine speed and power range. Active Sound Design (ASD), in conjunction with the original sound, makes the engine sound in the passenger compartment a desired overall experience .
- **Steering:** Is direct and precise, with variable M Servotronic (EPS) with Servotronic support (in three stages). M steering wheel with the M shift paddles includes two freely programmable MDrive buttons.

F80/F82 Complete Vehicle

1. Introduction

- **Chassis and suspension/Chassis and suspension dynamics design:** M sports suspension is available as optional equipment, selectable driving dynamics programs from comfort to sporty in three stages. Optimal driving precision and adapted interplay of steering, tires, suspension and damping action according to the selected program mode. Dynamic Stability Control (DSC) with M dynamic mode instead of Dynamic Traction Control (DTC).
- **Seating comfort:** Lightweight construction M seats (bucket seats).
- **Ergonomics of interior equipment:** M instrument cluster, MDrive menu, M seats, M-specific decorative strips, M driver footrests and door sill cover strips.
- **BMW ConnectedDrive** assistance systems and mobility services from the BMW ConnectedDrive scope, color Head-Up Display with M-specific scope, Professional Navigation system (SA609), M Lap Timer app.

1.3. F82 M4 Coupe vehicle profile



F82 M4 Coupe

TG14-0091

F80/F82 Complete Vehicle

1. Introduction

- **Design and aerodynamics:** The two-door high-speed sport Coupe has M-specific characteristics all around. Clever aerodynamic design of the front, side and rear sections as well as the vehicle underbody. The consistent lightweight construction is extended to the entire body.
- **Engine/Transmission:** 3-liter 6-cylinder engine Turbo-Valvetronic direct injection engine. Enhanced efficiency, while delivering even more power than the previous engine with regard to spontaneous linear power development. Choice of three engine dynamics control programs. Electronically controlled M rear-axle differential lock is standard equipment. The M Double-clutch Transmission with Drivelogic (M DTC) is available as an option. The consistent lightweight construction concept also extends to the design of the powertrain.
- **Engine sound:** Adds a Sporty character in the lower and upper engine speed and power range. Active Sound Design (ASD), in conjunction with the original sound, makes the engine sound in the passenger compartment a desired overall experience.
- **Steering:** Is direct and precise, with variable M Servotronic (EPS) with Servotronic support (in three stages). M steering wheel with the M shift paddles includes two freely programmable MDrive buttons.
- **Chassis and suspension/Chassis and suspension dynamics design:** M sports suspension is available as optional equipment, selectable driving dynamics programs from comfort to sporty in three stages. Optimal driving precision and adapted interplay of steering, tires, suspension and damping action according to the selected program mode. Dynamic Stability Control (DSC) with M dynamic mode instead of Dynamic Traction Control (DTC).
- **Seating comfort:** Lightweight construction M seats (bucket seats).
- **Ergonomics of interior equipment:** M instrument cluster, MDrive menu, M seats, M-specific decorative strips, M driver footrests and door sill cover strips.
- **BMW ConnectedDrive** assistance systems and mobility services from the BMW ConnectedDrive scope, color Head-Up Display with M-specific scope, Professional Navigation system (SA609), M Lap Timer app.

F80/F82 Complete Vehicle

2. Technical Data

2.1. Garage dimensions

M3

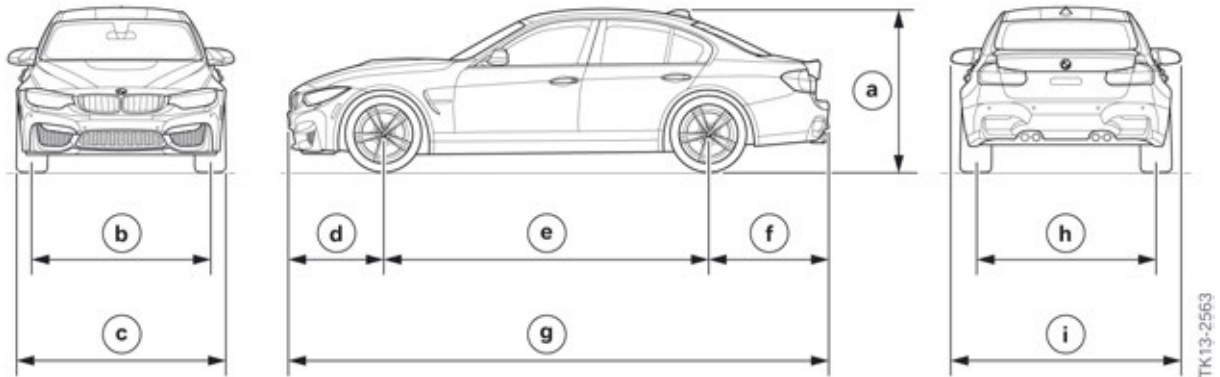

F80 M3 dimensions

Index	Explanation
a	1424 mm
b	1579 mm
c	1877 mm
d	811 mm
e	2812 mm
f	1048 mm
g	4671 mm
h	1603 mm
i	2037 mm

M4 Coupe

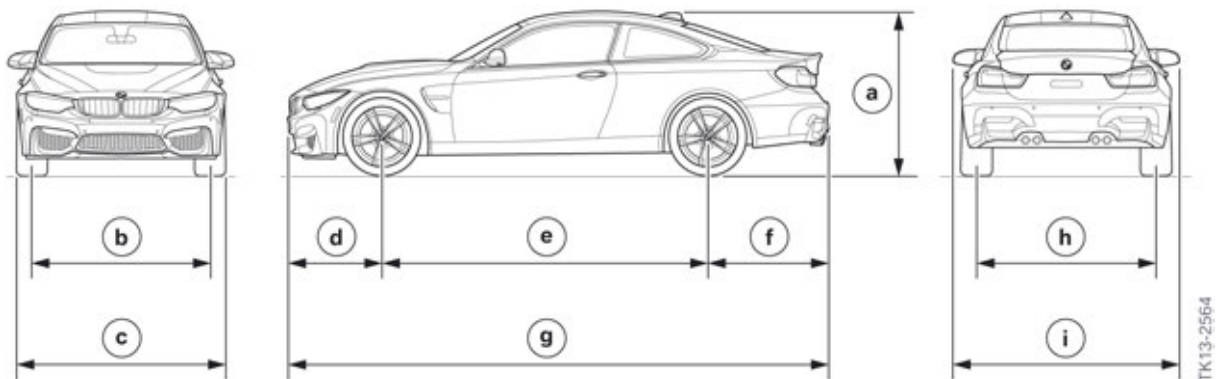

F82 M3 dimensions

TK13-2563

TK13-2564

F80/F82 Complete Vehicle

2. Technical Data

Index	Explanation
a	1383 mm
b	1579 mm
c	1870 mm
d	811 mm
e	2812 mm
f	1048 mm
g	4671 mm
h	1603 mm
i	2014 mm

2.2. Comparison of technical data in BMW

M3

Designation	Unit	E90 M3	F10 M5	F80 M3
Engine series		S65B40	S63B44T0	S55B30T0
Engine control		MS S60	MEVD17.2.8	MEVD17.2.G
Transmission type designation		GS7D36SG M DCT	GS7D36BG M DCT	GS7D36BG M DCT
Length	[mm]	4580	4910	4671
Width	[mm]	1817	1891	1877
Height	[mm]	1447	1456	1424
Number of seats		5	5	5
Luggage compartment volume	[l]	450	520	480
Max. speed	[km/h/mph]	250*/155*	250*/155*	250*/155*
Acceleration 0 - 60 mph	[s]	4.6	4.2	4.1
1,000 m, stationary start	[s]	23.3	21.9	21.9
Rolling acceleration 50-75 mph, 4th/5th gear	[s]	4.4/5.4	3.7/4.6	3.5/4.3
Nominal engine power at engine speed	[kW / bhp] [rpm]	309/414 8300	412/560*** 6000-7000	317/425 5500-7300
Power-to-weight ratio (DIN)	[kg/kW]	5.3	4.5	4.9
Torque at speed	[Nm/lb-ft] [rpm]	400/295 3900	680/500 1500-5750	550/406 1850-5500

F80/F82 Complete Vehicle

2. Technical Data

Designation	Unit	E90 M3	F10 M5	F80 M3
Aerodynamics:				
c_x (drag coefficient)		0,31	0,33	0,34
A (area)	[m ²]	2,23	2,40	2,29
$c_x \times A$ (drag)	[m ²]	0,69	0,79	0,78
Curb weight				
US ***	[kg/lbs]	1700	1945	1631/3595
Rear axle load section, empty (DIN)	[%]	48.8	47.1	47.9
Load capacity	[kg/lbs]	525/1157	540/1190	445/980
Permissible gross weight	[kg/lbs]	2150/4740	2410/5313	2121/4675
Fuel consumption	[l/100 km]	112	9.9	8.3
Fuel tank capacity	[l]	63	80	60
CO ² emissions	[grams per kilometer]	263	232	194
Exhaust emission standards		LEV II	ULEV II	ULEV II

* electronically regulated; vehicles with M DCT are 0.2 s faster 0–60 mph.

M4 Coupe

Designation	Unit	E92 M3	F82 M4 Coupe
Engine series		S65B40	S55B30T0
Engine control		MS S60	MEVD17.2.G
Transmission type designation		GS7D36SG M DCT	GS7D36BG M DCT
Length	[mm]	4615	4671
Width	[mm]	1804	1870
Height	[mm]	1424	1383
Number of seats		4	4
Luggage compartment volume	[l]	430	445
Max. speed	[km/h/mpg]	250*/155*	250*/155*
Acceleration 0 - 60 mph	[s]	4.5	4.1
1,000 m, stationary start	[s]	22.9	21.9
Rolling acceleration 50–75 mph, 4th/5th gear	[s]	4.2/5.2	3.5/4.3
Nominal engine power at engine speed	[kW / bhp] [rpm]	309/414 8300	317/425 5500–7300

F80/F82 Complete Vehicle

2. Technical Data

Designation	Unit	E92 M3	F82 M4 Coupe
Power-to-weight ratio (DIN)	[kg/kW]	5.2	4.8
Torque at speed	[Nm / lb-ft] [rpm]	400/295 3900	550/406 1850–5500
Aerodynamics:			
c_x (drag coefficient)		0,31	0,34
A (area)	[m ²]	2,17	2,23
$c_x \times A$ (drag)	[m ²]	0.67	0,76
Curb weight			
US ***	[kg/lbs]	1675	1626/3585
Rear axle load section, empty (DIN)	[%]	48,3	47,5
Load capacity	[kg/lbs]	480/1058	390/860
Permissible gross weight	[kg/lbs]	2080/9435	2062/4545
Fuel consumption	[l/100 km]	11.2	8.3
Fuel tank capacity	[l]	63	60
CO ² emissions	[grams per kilometer]	263	194
Exhaust emission standards		LEV II	ULEV II

* electronically regulated; vehicles with M DCT are 0.2 s faster 0–60 mph.

2.2.1. BMW EfficientDynamics measures

- TwinPower Turbo Technology.
- Gasoline direct fuel injection with Valvetronic.
- Automatic engine start-stop function.
- Consistent, intelligent lightweight construction through the use of carbon, aluminum and magnesium.
- 7–speed M DCT with Drivelogic/efficient 6–speed manual gearbox.
- M Servotronic (EPS).
- Shift point Display.
- Use of ancillary components as required (air conditioning compressor).
- Li-ion battery (for the improvement of the brake energy regeneration-lightweight construction concept).
- Brake energy regeneration.

F80/F82 Complete Vehicle

2. Technical Data

2.3. BMW M3 and M4 Coupe compared to competitors

2.3.1. M3

Designation	Unit	F80 M3	Mercedes C 63 AMG
Engine series		In-line/6	V/8
Capacity	[cm ₃]	2979	6208
Nominal engine power at engine speed	[kW / bhp] [rpm]	317/425 5500–7300	336/457 6800
Torque at speed	[Nm / lb-ft] [rpm]	550/406 1850–5500	600/443 5000
Acceleration 0 - 60 mph	[s]	3.9 ^{***} /4.1	4.4
Max. speed	[km/h]	250 [*] /280 ^{**}	250 [*] /280 ^{**}
Fuel consumption	[l/100 km]	8.3 ^{***} /8.8	12
CO ² emissions	[grams per kilometer]	194 ^{***} /204	280
Length	[mm]	4671	4702
Width	[mm]	1877	1770
Height	[mm]	1424	1433
Wheelbase	[mm]	2812	2760
Luggage compartment volume	[l]	480	475
Curb weight US	[kg/lbs]	1631 ^{***} /3595 ^{***} 1606/3540	1730/3813

* electronically regulated; ** electronically regulated in conjunction with SA 7ME M Drivers Package;
*** M DCT

F80/F82 Complete Vehicle

2. Technical Data

2.3.2. M4 Coupe

Designation	Unit	M4 Coupe	Audi RS 5 Coupe	Mercedes C 63 AMG Coupe
Engine series		In-line/6	V/8	V/8
Capacity	[cm ³]	2979	4163	6208
Nominal engine power at engine speed	[kW / bhp] [rpm]	317/431 5500–7300	331/450 8250	336/457 6800
Torque at speed	[Nm / lb-ft] [rpm]	550/406 1850–5500	430/317 4000–6000	600/443 5000
Acceleration 0 - 60 mph	[s]	3.9 ^{***} /4.1	4.5	4.4
Max. speed	[km/h]	250*/280**	250*/280**	250*/280**
Fuel consumption	[l/100 km]	8.3 ^{***} /8.8	10.5	12
CO ² emissions	[grams per kilometer]	194 ^{***} /204	246	280
Length	[mm]	4671	4649	4707
Width	[mm]	1870	1860	1795
Height	[mm]	1383	1366	1391
Wheelbase	[mm]	2812	2751	2760
Luggage compartment volume	[l]	445	455	450
Curb weight US	[kg/lbs]	1626 ^{***} /3585 ^{***} 1601/3530	1790/3946	1730/3813

* electronically regulated; ** electronically regulated in conjunction with SA 7ME M Drivers Package (not in US); *** M DCT

F80/F82 Complete Vehicle

3. Body

3.1. Bodyshell

3.1.1. Chassis and suspension components and rigidity concept

Front area of vehicle

The following measures were implemented in the front section of the vehicle for the connection of the chassis and suspension components and to increase the vehicle rigidity:

- Screw connection of the steel brace strut extensions and F80/F82-specific mounting points at the A-pillar and in the area of the spring strut dome.
- Carbon brace strut
- Front axle support
- Stiffening plate
- Front-end reinforcements of the engine support made from aluminum behind the cooling module.

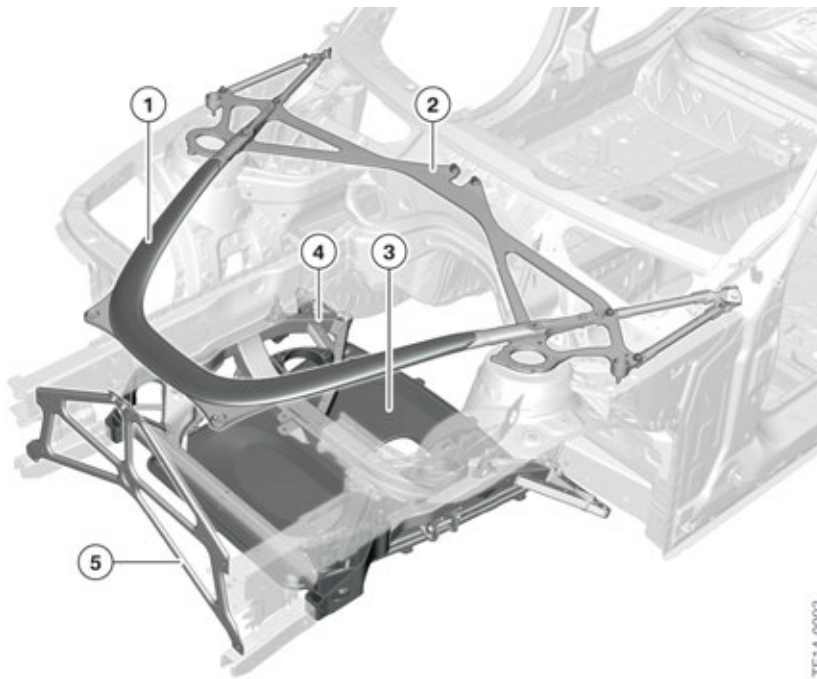

Measures in the front area

Index	Explanation
1	Carbon brace strut
2	Brace strut extensions
3	Stiffening plate
4	Front axle support
5	Reinforcement in the front section of the vehicle

F80/F82 Complete Vehicle

3. Body

Rear area of the vehicle

The following measures were implemented in the rear section of the vehicle for the connection of the chassis and suspension components and to increase the vehicle rigidity:

- Direct screw connection of the rear axle support to the body without the use of rubber mounts.
- Additional struts from the rear axle support to the tunnel and side sill unit.

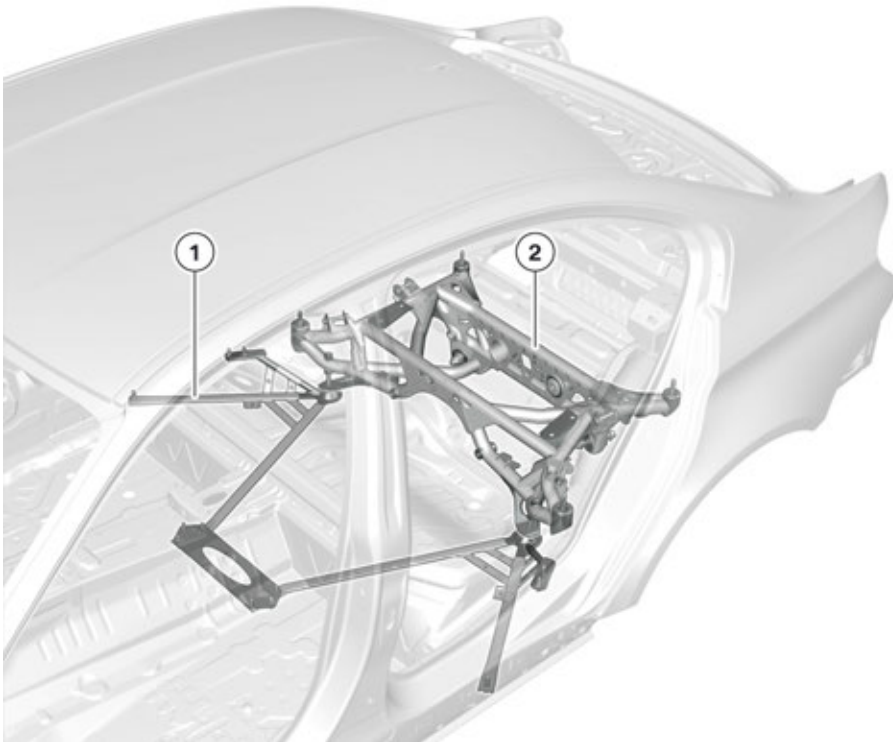

Measures in the rear area

Index	Explanation
1	Tunnel-side sill area struts
2	Rear axle support



Details can be found in the information and specifications of the documents in the Integrated Service Technical Application (ISTA).

F80/F82 Complete Vehicle

3. Body

3.2. Exterior

3.2.1. Front view

Bumper, front

The bumper panel in the M-specific design has flaps at the bottom for reducing the drive at the front axle. It is painted in the vehicle color, including the PDC sensors. Due to the necessary air inlets no fog lights are offered. The frame and the double-bridge longitudinal bars of the kidney grill of the BMW M radiator grill are standard high-gloss black struts for the M3/M4 Coupe and have the M3/M4 Coupe model designation. The optional Side View camera and the Parking Maneuvering Assistant (PMA) sensor is integrated at the side similar to the F3x production vehicle.

In addition, the Air Curtain was integrated in the front bumper panel and the neighboring wheel arch panel. The Air Curtain, together with the side gill form part of the integrated Air Breather function. The underbody panels, a rear spoiler and the exterior mirrors, contribute to the aerodynamics concept of the new M3/M4 Coupe.

The ornamental grills at the bottom are black-grained.



F82 M4 Coupe, front view

Headlights

The front headlights are adopted from the F32/F33. They were adapted to their position and the front of the M3/F80 was adapted to the headlight shape and position.

F80/F82 Complete Vehicle

3. Body

Engine compartment lid

In contrast to the F3x M3, the engine compartment lid for the F80/F82 is made from aluminum.

Six struts were fitted in the middle section to reinforce the engine compartment lid.

The supporting inner structure, as well as the outer skin of the engine compartment lid, are made from aluminum. The sound insulation in the passenger compartment of the engine compartment lid is deleted.

The typical M "power dome" is functional. It provides the space for the indirect charge air cooling for the S55B30T0 engine.

These measures result in weight savings of about 8 kg/ 17.6 lbs in comparison to the F3x M3.

Front end and air ducts

The air intake duct and the intake silencer, as well as their position, are also new.



F80/F82 air intake duct and indirect charge air cooler

There is a new air duct both for the center radiator package and for the upper low-temperature radiator and the two radiators in the wheel arches. For rigidity reasons the lower engine compartment shield is a one-piece design. It includes the air duct of the horizontal engine oil cooler and optimizes its flow. The lower bumper support comprises a plastic component which saves on weight and is secured to the M3/M4 Coupe deformation elements. The shaped element in the upper bumper support is adapted to the shape of the M3/M4 Coupe bumper panel.

The low design of the front end including the engine compartment lid form part of the passive pedestrian protection.

F80/F82 Complete Vehicle

3. Body

3.2.2. Side view



F82 M4 Coupe, side view

Exterior mirror and sill

The exterior mirrors are heated (as standard equipment) and are electrochromic shaded with integrated side repeaters, have memory and fold-in functions and the passenger side mirror an automatic parking function. The mirror triangle and mirror cap at the bottom, including the weather strips, are also grained as standard equipment.

The M3/M4 Coupe exterior mirrors have a prominent design and have been enhanced in terms of their aeroacoustic properties. The full panel covering of the side sill has also been enhanced in terms of aerodynamics.



F80 M3 gill and mirror

F80/F82 Complete Vehicle

3. Body

Front fenders

The front fenders of the F80/F82 are made from aluminum. There is an overall weight saving of 2.6 kg / 5.7 lbs for the two fenders in comparison to the steel fenders of the F3x M3.

Striking design features include the M gills and the M3/M4 Coupe model inscription on the left/right front fenders. In addition, for the first time in a BMW M vehicle the Air Breathers are used on the left and right in the fenders, which were integrated in the typical M gill.

The front fenders are also new due to the tire clearance. The fender flares were enlarged about 28 mm for the F80 compared to the F30 and about 18 mm from the F82 compared to the F32.

Quarter panel

The rear panel is also new due to the tire clearance.

Wheel arch cover

The wheel arch cover and the covers of the steering units are adapted to the quarter panels.

F80/F82 Complete Vehicle

3. Body

Roof

The roof operating unit for the F80/F82 is made from a carbon fiber structure and is connected to the body by bonding. The roof line has an aerodynamic outline in the middle section, thus highlighting the sporting character of the new M3/M4 Coupe.

For the first time a CFRP roof is also used for a M3 Sedan. If the customer decides in favor of an electrical glass sunroof in the new M3/M4 Coupe, the CFRP roof is deleted and a steel roof, similar to the F3x M3, is installed.

The production of the CFRP roof is done as a multi-layer design in the RMT process (transfer moulding) and is sealed with a layer of clear coat. In comparison to the standard steel roof, this CFRP roof saves about 5 kg / 11 lbs in weight in the M3 and about 6.5 kg / 14.3 lbs in the M4 Coupe.

A CFRP convertible top bow is used as a supplement and support for the CFRP roof in the M4 Coupe. This CFRP convertible top bow sits in the middle at the height of the B-pillar and has a hybrid design. In comparison to the standard version, another 1.5 kg / 3.3 lbs could be saved with the use of this CFRP convertible top bow.

The CFRP roof structure thus also contributes to the consistent lightweight construction concept of the new M3/M4 Coupe.



F80 M3 CFRP roof

F80/F82 Complete Vehicle

3. Body

Rim design

Forged 18" M BMW light-alloy wheels are used as standard at the front and rear. Mixed tires with the sizes 255/40 ZR18 at the front and 275/40 ZR18 at the rear are used. The forged M BMW light-alloy wheels with 19" and the mixed tires in the size 255/35 ZR19 at the front and 275/35 ZR19 at the rear can also be ordered as optional equipment in two different colors. For more information please see the chapter "Wheels/tires".

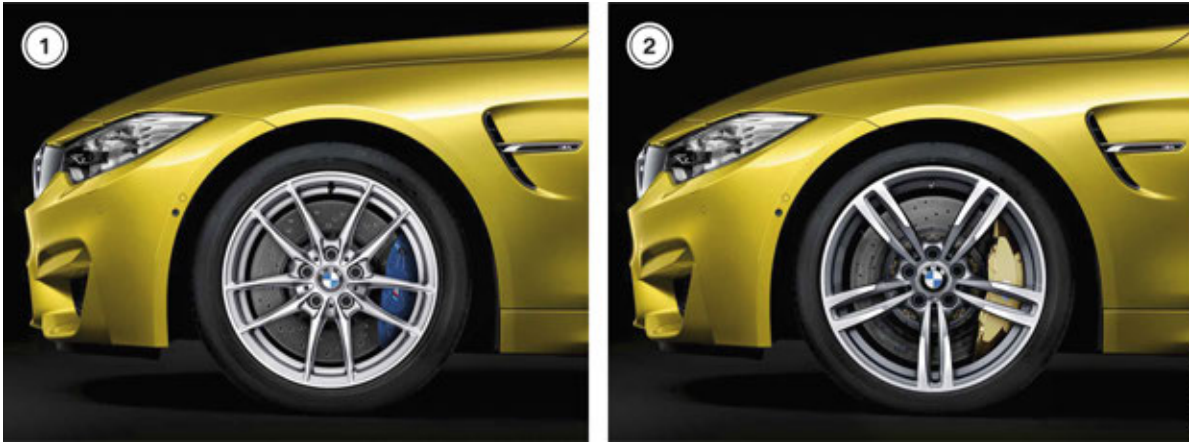

F80/F82 rim design

Index	Explanation
1	18" M standard wheel
2	19" M wheel, optional equipment, two colors

F80/F82 Complete Vehicle

3. Body

3.2.3. Rear quarter panel and rear view

Rear quarter panel

The rear quarter panel was widened and adapted to house the modified chassis and suspension components of the new M3/M4 Coupe.

A striking design feature is the four round exhaust tailpipes.



F80 M3 Rear view

The rear bumper panel accommodates the exhaust system and its aerodynamics have been enhanced. The PDC sensors are painted in the vehicle colors. The shaped element in the bumper support is adapted to the shape of the M3/M4 Coupe bumper panel.

F80/F82 Complete Vehicle

3. Body

3.2.4. Trunk lid

Trunk lid F80 M3

The trunk lid of the F80 M3 is a standard part adopted from the F30. It is enhanced with a M-specific rear spoiler edge (Gurney). The rear diffuser and the Gurney increase the downforce at the rear axle, in particular at higher speeds.

The Gurney is an aerodynamic component (named after the former Formula 1 driver) which functions as a tear-off edge. The Gurney enhances downforce at the rear axle and thus contributes to the optimization of the driving dynamics.



F80 M3 Gurney

Trunk lid of F82 M4 Coupe

The trunk lid of the F82 M4 Coupe is a new design especially for the M4 Coupe, it was modelled after the BMW M3 CSL. It's made from carbon and other fiber composites C-SMC, similar to previous vehicles (F12, F13, F06, E63 and E64).

The shape of the trunk lid was enhanced for perfect aerodynamics so that no additional rear spoiler edge is necessary due to the integrated tear-off edge (Gurney).

The exterior shell at the top and bottom is made from hollow glass spheres in the Low Density-Sheet Moulding Compound (LD-SMC) procedure. The mounting (including the threads) is made from sheet steel and cathodic dipped (E-coated) and then bonded to the interior shell. The interior shell is made from carbon fibers in the Carbon Fiber-Sheet Moulding Compound (C-SMC).

The trunk lid of the M4 Coupe has its own M styling, adapted to the M4 Coupe rear fenders, and the contoured line of the CFRP roof is continued into the trunk lid.

The trunk lid of the F82 is longer and higher in comparison to the F32, and is about 5 kg / 11 lbs lighter.

F80/F82 Complete Vehicle

3. Body



F82 M4 Coupe, trunk lid



Further information on the installation-disassembly and repair of the trunk lid can be found in ISTA (Integrated Service Technical Application).

3.2.5. Underbody and thermal protection

Underbody

The entire vehicle underbody is fully cladded and thus integrated into the aerodynamics concept of the M3/M4 Coupe, in order to reduce lift at the front and rear axle and distribute it evenly. This highlights and optimizes the driving dynamics concept, particularly at higher speeds. The underbody panels were adapted in terms of the cooling and flow around and through the drive components as well as chassis and suspension components, without compromising the aerodynamics concept.

Thermal protection

New heat insulation:

- The heat insulation of the underbody panels is new.
- The heat insulation of the fuel tank is new.
- The heat insulation of the tunnel is new.
- The heat insulation of the front and rear silencer is new.
- A completely new heat insulation of the luggage compartment prevents it from heating up too much due to the hot exhaust air flow near the rear axle differential.

F80/F82 Complete Vehicle

3. Body

3.3. Interior

3.3.1. Driving area and steering wheel

M driving area



F80/F82 driving area

For the full Merino leather upholstery (option X3) the instrument panel at the top and the door sills are covered with black Nappa leather and leather Merino in the upholstery color at the bottom of the instrument panel.

F80/F82 Complete Vehicle

3. Body

M leather steering wheel

The M leather steering wheel with multifunction is built on a magnesium armature and is based on the steering wheel used with F10 M5. Above the thumb rests are the M gearshift paddle with M shifting logic (left downshift, right upshift).

In comparison to the F3x M3, the inner diameter of the steering wheel was reduced by 8 mm and the outer diameter by 2 mm. The steering wheel rim was reinforced to 31.6 mm in comparison to the standard version and enhanced in terms of ergonomics from a round to an oval cross-section which improves the grip.

The color M stitching is another difference to the F3x M3. The M leather steering wheel in the double-spoke design with a stainless steel center trim and with M inscription is black leather. Steering wheel heating and the lane change warning are available as optional equipment.

Two MDrive buttons are integrated in the left multifunction field. For more details please see the chapter "M Drive menu".



F80/F82 M steering wheel

3.3.2. Leather trim

Four colors of the leather interior equipment highlight the connection of the BMW M3/M4 Coupe to motor racing in different ways. In addition to deep black, Silverstone portrays the cool technical sporting character of the model, whereas Sakhir Orange highlights the dynamics and superior force of the model, and Sonoma Beige emphasizes classic modernity.

F80/F82 Complete Vehicle

3. Body

3.3.3. Seats

M sport seats

10-way power front M sport seats with single-piece back panel, 4-way lumbar support, power-adjustable side bolsters and backlit M logo on backrest. Includes memory system for driver's seat and outside mirrors (2 positions). Anthracite Carbon Structure Cloth/Leather upholstery is standard equipment.

The following equipment is available for the M sport seat in the US market:

- Fully electric seat adjustment with memory function for the driver's side (standard).
- Seat heating for driver and front passenger (standard).
- Full Merino leather (optional).
- Extended Merino leather (optional).



M bucket seats

F80/F82 Complete Vehicle

3. Body

Rear seat with lightweight through-load system

The rear M seats also have a sport style, similar to the front seats. The rear row of seats is designed to split into a 60:40 combination.

The rear row of seats is also distinguished by its design as a lightweight through-loading facility. With this design the backrest support structure is made in polypropylene injection moulding and reinforced with 30% glass fiber in sandwich technology.

This design results in a weight saving of about 6 kg / 13.2 lbs in comparison to the standard part.

Possible optional equipment for the rear seat:

- Seat heating for the F80/M3
- Merino leather and Merino full leather
- Ski bag

3.3.4. Doors and decorative strips

Doors

The door trim panels have been adapted and are M-specific. In the basic version the exterior mirrors are in fabric, the armrests and handles are in Dakota leather.

Other equipment details can be found in the sales documentation.

M3/M4 Coupe, interior design

- "Blue Shadow" decorative strips as standard and "Aluminum Blade" decorative strip as optional equipment. These interior trim finishers are currently only offered for the F80/F82.
- Carbon decorative strips specific to M as known from the F12/F13 M.
- Fine wood trim Fine-line Anthracite adopted from the production vehicles of BMW AG.

The interior trim finishers are located in the instrument panel.

- The door sill cover strips have a M3/M4 Coupe inscription.
- M footrest with a stainless steel design and M emblem.
- The function panel M DCT Drivelogic is in fine-brushed aluminum with Drivelogic button.

F80/F82 Complete Vehicle

4. Powertrain

4.1. Engine S55B30T0

The S55B30T0 engine is described in its own manual, the ST1404 S55 Motorsport Engine reference manual (available in ICP and TIS).



F80/F82 S55B30T0 Engine

4.2. Transmission

4.2.1. Manual gearbox

In the F80/F82 a manual gearbox is installed as standard equipment. It is an enhanced version of the familiar K-transmission, which is known from the production vehicles of BMW AG. The transmission was adapted to the higher power requirements of the M3/M4 Coupe.

F80/F82 Complete Vehicle

4. Powertrain

The following components were modified:

- Weight reduction of about 12 kg/ 26 lbs in comparison to the previous transmission in the E9x M3.
- Smaller in size which contributes to the lower weight.
- Improved shifting comfort due to use of new type of carbon friction lining in the synchronization units.
- Increased efficiency with dry sump lubrication ("splash" lubrication and targeted oil ducts are no longer used). This results in a reduction of heat development to the extent that external cooling (like in the E9x M3) is not necessary.
- Reduction of noise level.

Engine speed adaptation for a gear change

The new F80/F82 engine uses speed adaptation for the manual gearbox (Similar to the production vehicles with the B-engines with manual gearboxes). The engine speed adaptation further highlights the sporting character of the new F80/F82 and its motor racing genes.

In addition, the engine speed adaptation is used to reduce the drag torque and improve the driving stability in the dynamic handling characteristics at the limit range.

The engine speed during a gear change is automatically adapted to the new transmission ratio. The engine and the transmission input shaft thus have the same speed when engaging the clutch. This ensures the clutch is always engaged smoothly.

The corresponding engine speed is calculated by the DME and held for a maximum of two seconds.

With M Driving Modes the engine speed is adapted at different rates depending on the driving mode.

For the control the clutch pedal must be pressed fully when switching.

The engine speed adaptation for the gear change is not active.

The engine speed adaptation for a gear change can be deactivated via the diagnosis system.

The engine speed adaptation includes the following components and functions:

- New gear sensor via x-y axle, detects gearshift request and communicates directly with the engine control unit.
- Clutch switch is two-stage and communicates directly with the DME.
- Engine speed adaptation characteristic is based on the selected driving mode.
- No reverse gear switch as detection via gear sensor.

The function of the engine speed adaptation in the F80/F82 differs to the F10 M5 in the following point:

- The detection of the transmission input speed was done at a gear (constant gear) in the transmission. The determination of the transmission ratio had to be calculated from the wheel speed (counted back to transmission output speed) and transmission input speed.

F80/F82 Complete Vehicle

4. Powertrain



The engine speed adaptation is switched off in the Engine Dynamics Control “Sport Plus” (Throttle response) mode in order to give the driver full control over the vehicle.



The neutral sensor is capable of self-diagnosis and if necessary can input a fault in the fault memory. An additional display is not done. After the replacement of the gear sensor it must be re-calibrated with help of the BMW diagnosis system.

4.2.2. Clutch

A double-disc clutch is installed in combination with the manual gearbox. The operating principle of the clutch is identical to the double-disc clutch systems already used.

4.2.3. M double-clutch transmission (M DCT) with Drivelogic

The GS7D36BG M DCT with Drivelogic is available as optional equipment.

The DCT in the new F80/F82 has the same technical features as the DCT in the F10 M5, F12 M6, F13 M6, and F06 M6.

The M Double-clutch Transmission with Drivelogic was used (for the first time) in the E93 M3 with the S65B40 engine with the designation GS7D36SG. This transmission is described in the M DCT web course and in the ST813 M DCT transmission training manual available in ICP and TIS.

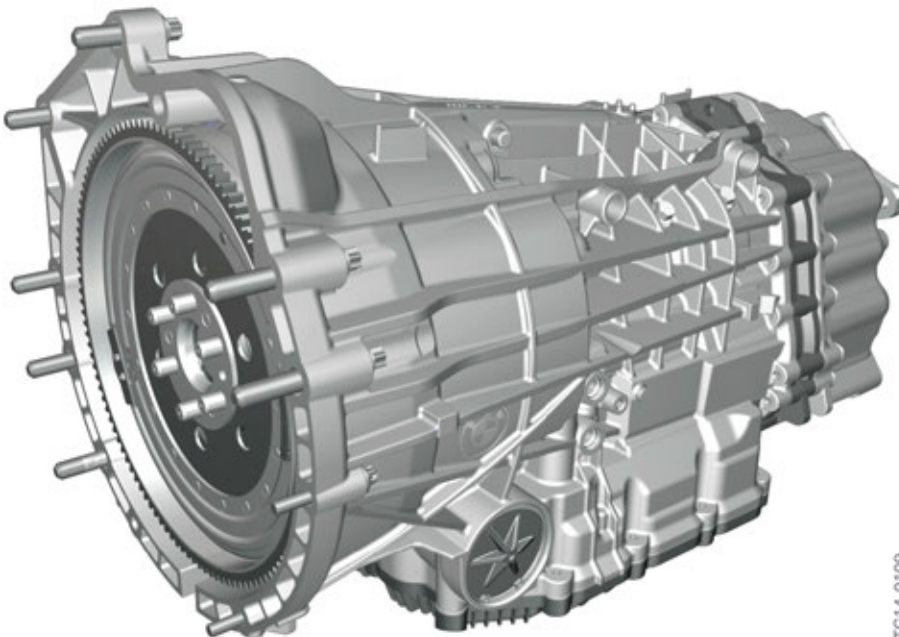

TG14-0109

F80/F82 external view, M DCT Drivelogic

F80/F82 Complete Vehicle

4. Powertrain

The following changes have been introduced to adapt the DKG to the F80/F82:

- Adapted transmission housing for the S55 engine
- Removal of the emergency gearbox release (parking lock)
- New thermostat with modified temperature map
- New mechatronics module to satisfy future software requirements

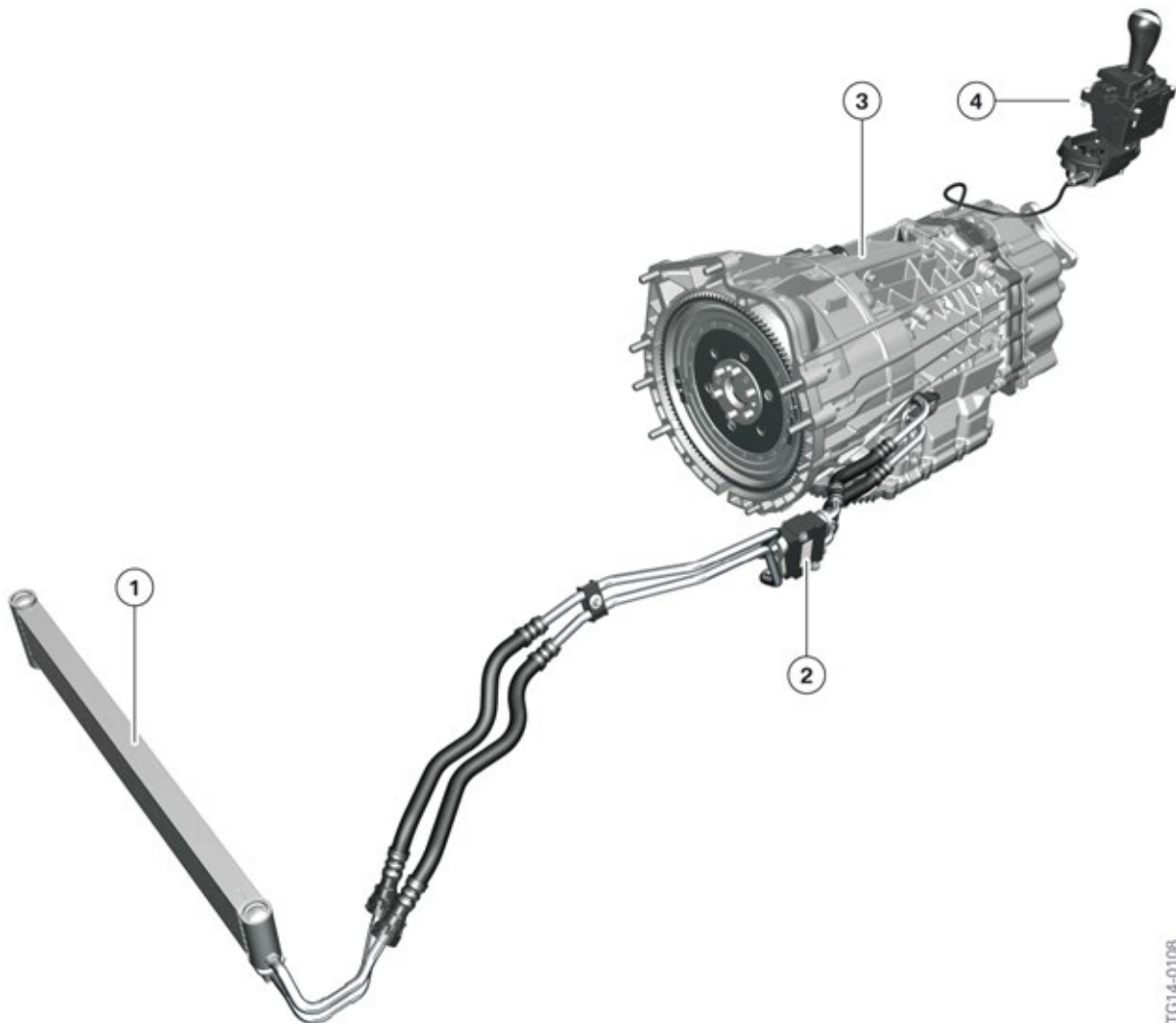

F80/F82 M DCT Drivelogic with external oil circuit

TG14-0108

Index	Explanation
1	Transmission oil cooler
2	Thermostat
3	M Double-clutch Transmission Drivelogic
4	M gear selector switch

F80/F82 Complete Vehicle

4. Powertrain

4.2.4. Structure and power flow

Design

The transmission housing and the shaft bearing were adopted in their existing form from the GS7D36BG. However the connection to the engine (bell housing) was adapted for the S55.

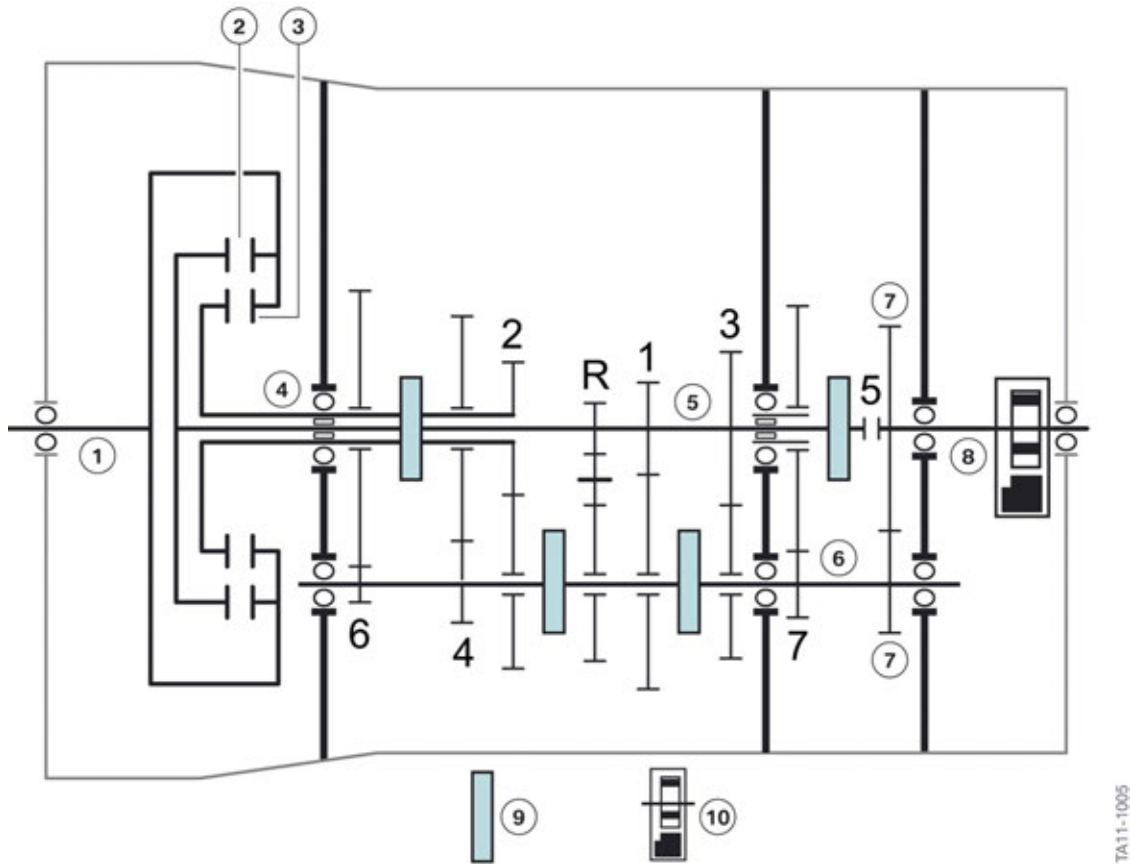

F80/F82 M DCT structure and bearing

Index	Explanation
1	Central input shaft with clutch input
2	Clutch 1
3	Clutch 2
4	Inner input shaft 2
5	Inner input shaft 1
6	Auxiliary shaft
7	Constant gears
8	Output shaft
9	Selector sleeves
10	Parking lock

F80/F82 Complete Vehicle

4. Powertrain

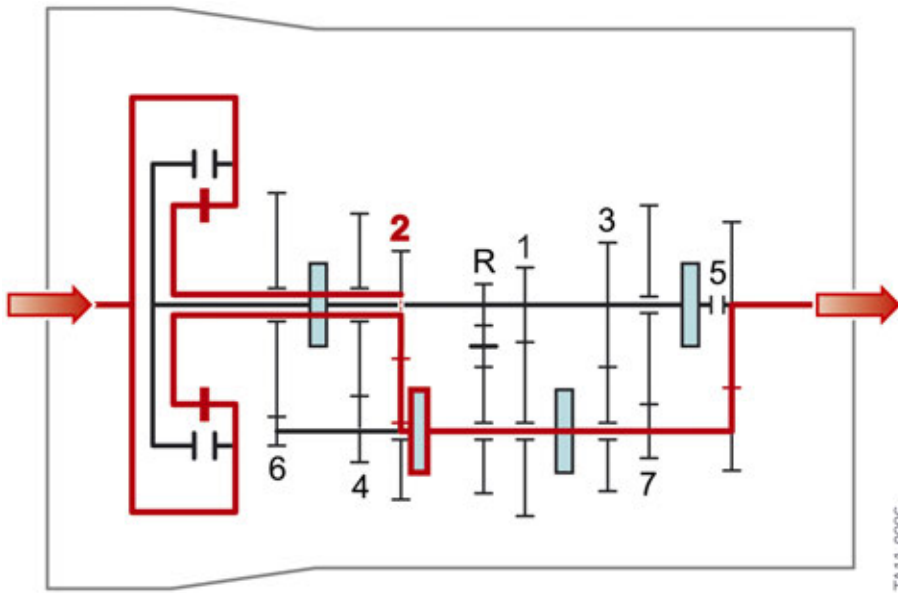

F80/F82 M DCT, 2nd gear

TA11-0996

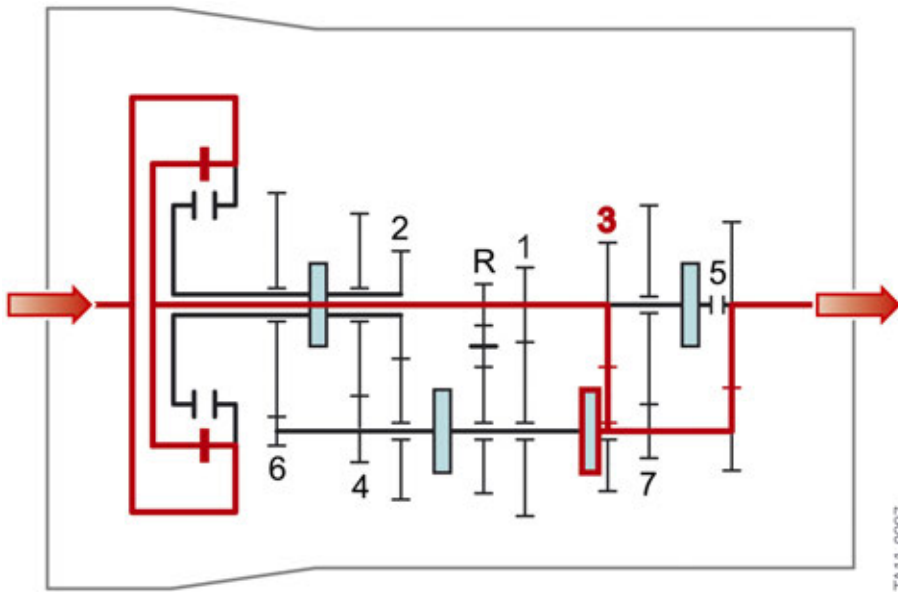

F80/F82 M DCT, 3rd gear

TA11-0997

F80/F82 Complete Vehicle

4. Powertrain

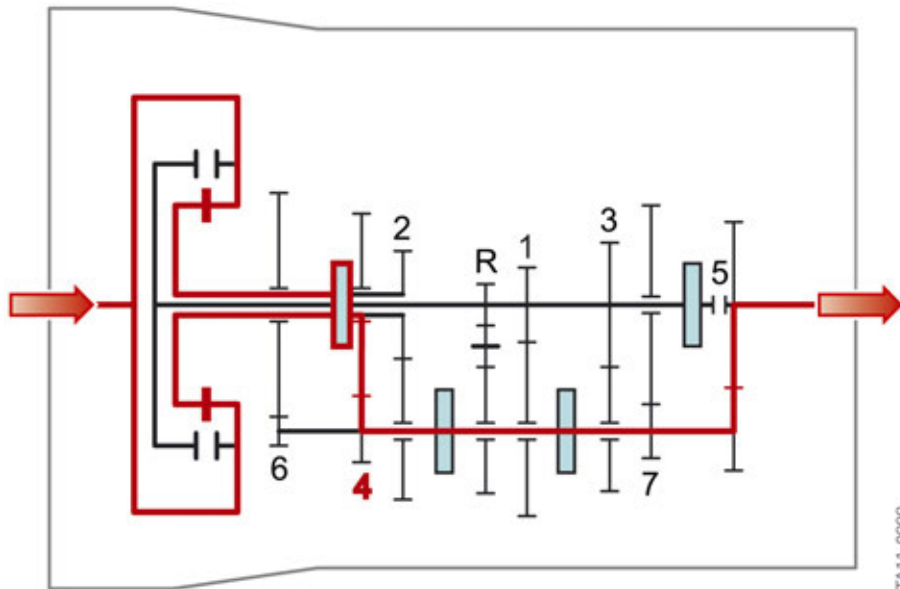

F80/F82 M DCT, 4th gear

The fifth gear was stepped up for the E9x M3 and is now the direct gear in the F1x M5/M6 and F8x M3/M4 Coupe.

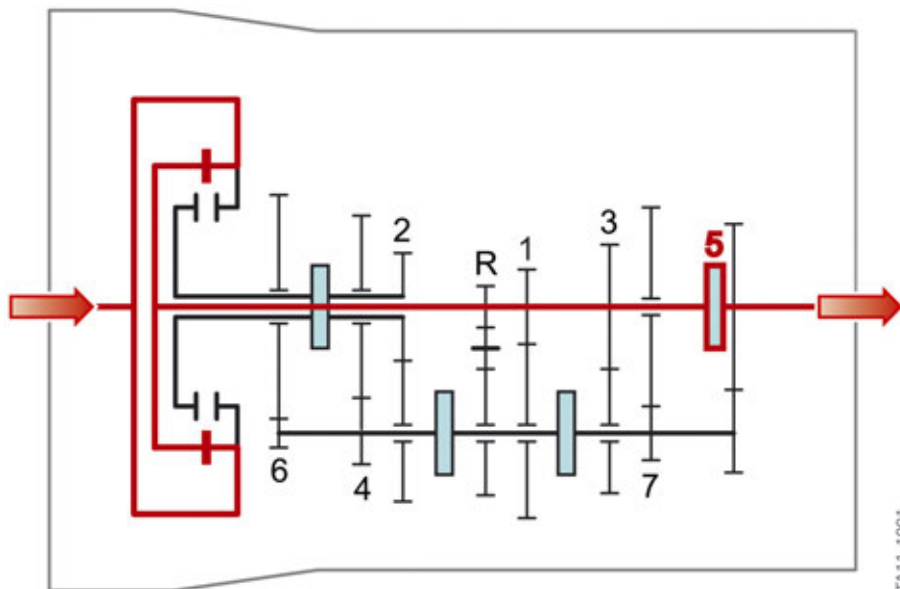

F80/F82 M DCT, 5th gear (direct gear)

F80/F82 Complete Vehicle

4. Powertrain

The sixth gear was stepped up for the E9x M3 and is now reduced in the F1x M5/M6 and F8x M3/M4 Coupe.

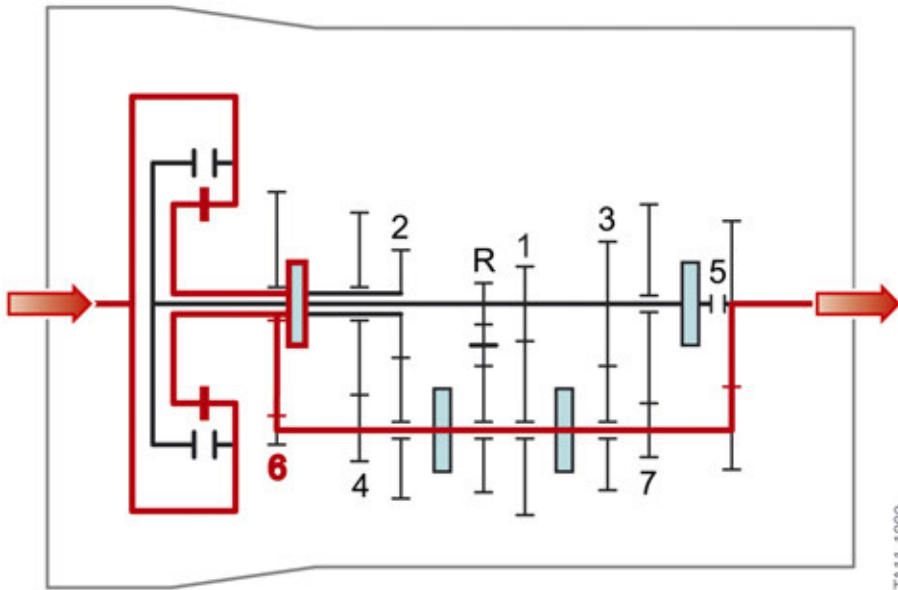

F80/F82 M DCT, reduced 6th gear

The seventh gear was the direct gear in the E9x M3 and is now reduced in the F1x M5/M6 and F8x M3/M4 Coupe.

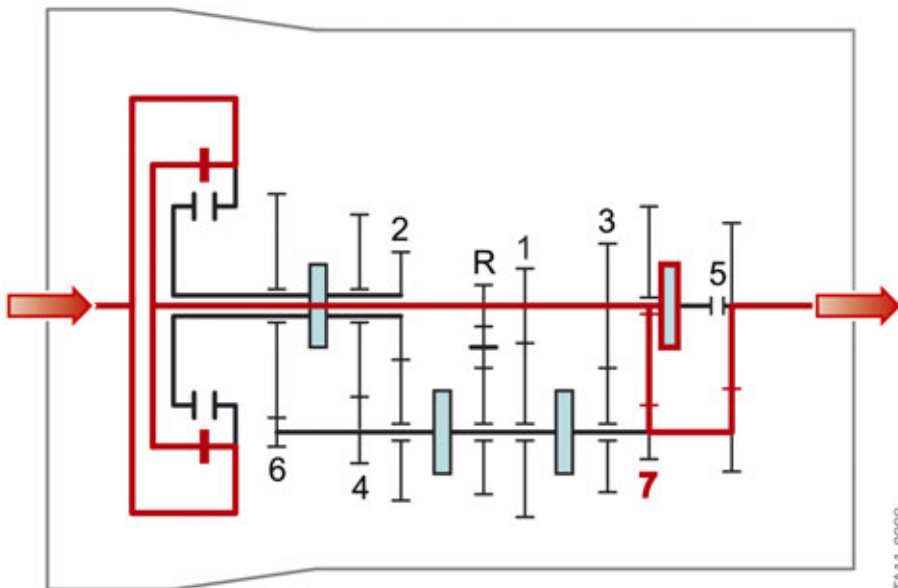

F80/F82 M DCT, reduced 7th gear

F80/F82 Complete Vehicle

4. Powertrain

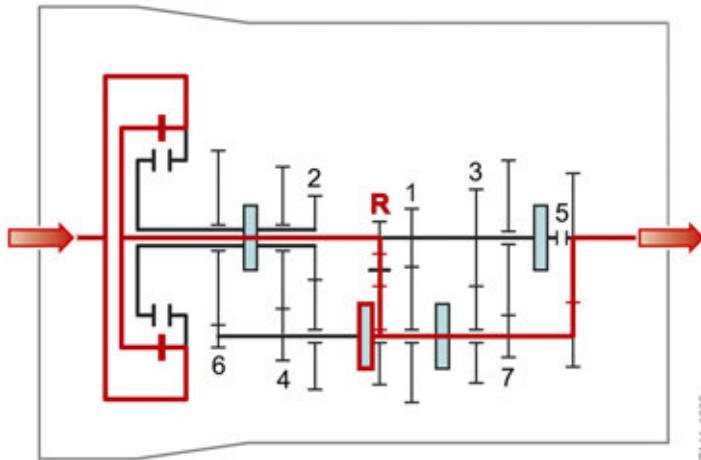

F80/F82 M DCT, reverse gear

4.2.5. Technical data of M DCT

GS7D36BG in the F80/F82 and F1x M vehicles in comparison to GS7D36SG in the E9x M3

Vehicle	E9x M3	F1x M vehicles	F80/F82– M3/M4 Coupe
Gear ratio spread*	4.8	7.2	7.2
Maximum engine speed [rpm]	9000	7500	7600
Selection torque [Nm / lb-ft]	520/384	700/516	700/516
Dry weight without dual-mass flywheel [kg]	85	85	83.2
	Ratio [:1]	Ratio [:1]	Ratio [:1]
Constant	1,630	1,630	1,630
Switch position			
1st gear	4,780	4,806	4,806
2nd gear	3,056	2,593	2,593
3rd gear	2,153	1,701	1,701
4th gear	1,678	1,277	1,277
5th gear	1,390	1,000	1,000
6th gear	1,203	0,844	0,844
7th gear	1,000	0,671	0,671
Reverse gear	4,454	4,172	4,172
Rear axle	3.154	3.154	3.462

* The Gear ratio spread is calculated by dividing the gear ratio of the first gear by the highest forward gear.

F80/F82 Complete Vehicle

4. Powertrain

4.2.6. System information

System wiring diagram

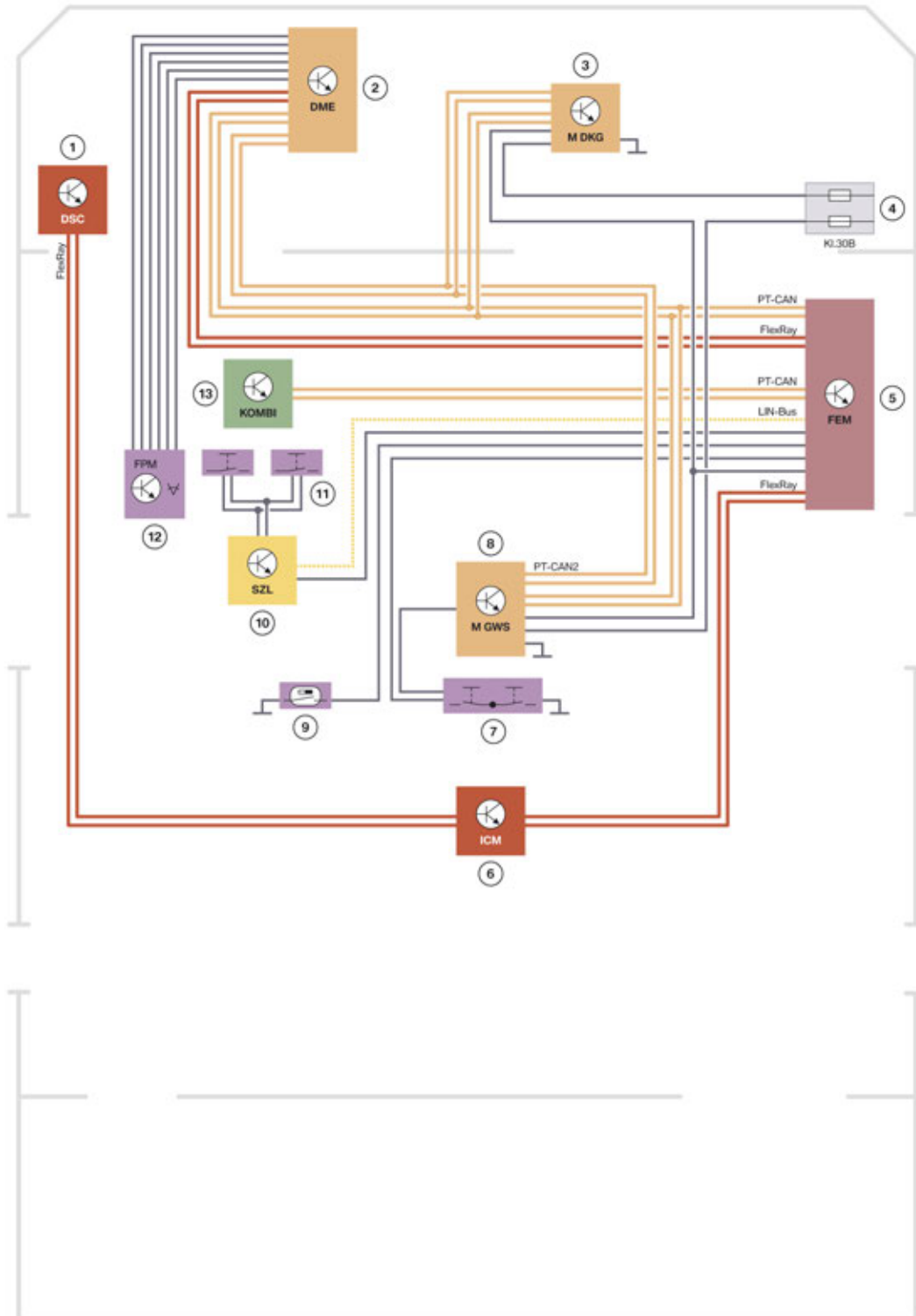

F80/F82 Complete Vehicle

4. Powertrain

Index	Explanation
1	Dynamic Stability Control (DSC)
2	Digital Motor Electronics (DME)
3	M Double-clutch Transmission (M DCT) with Drivelogic
4	Power distribution box, front
5	Front Electronic Module (FEM)
6	Integrated Chassis Management (ICM)
7	Drivelogic button
8	M gear selector switch (M GWS)
9	Brake light switch
10	Steering column switch cluster (SZL)
11	M steering wheel shift paddle
12	Accelerator pedal module
13	Instrument panel (KOMBI)

F80/F82 Complete Vehicle

4. Powertrain

Inner sensor system

The sensor system was able to be adopted unchanged from the GS7D36BG of the F1x M5/M6 vehicles.

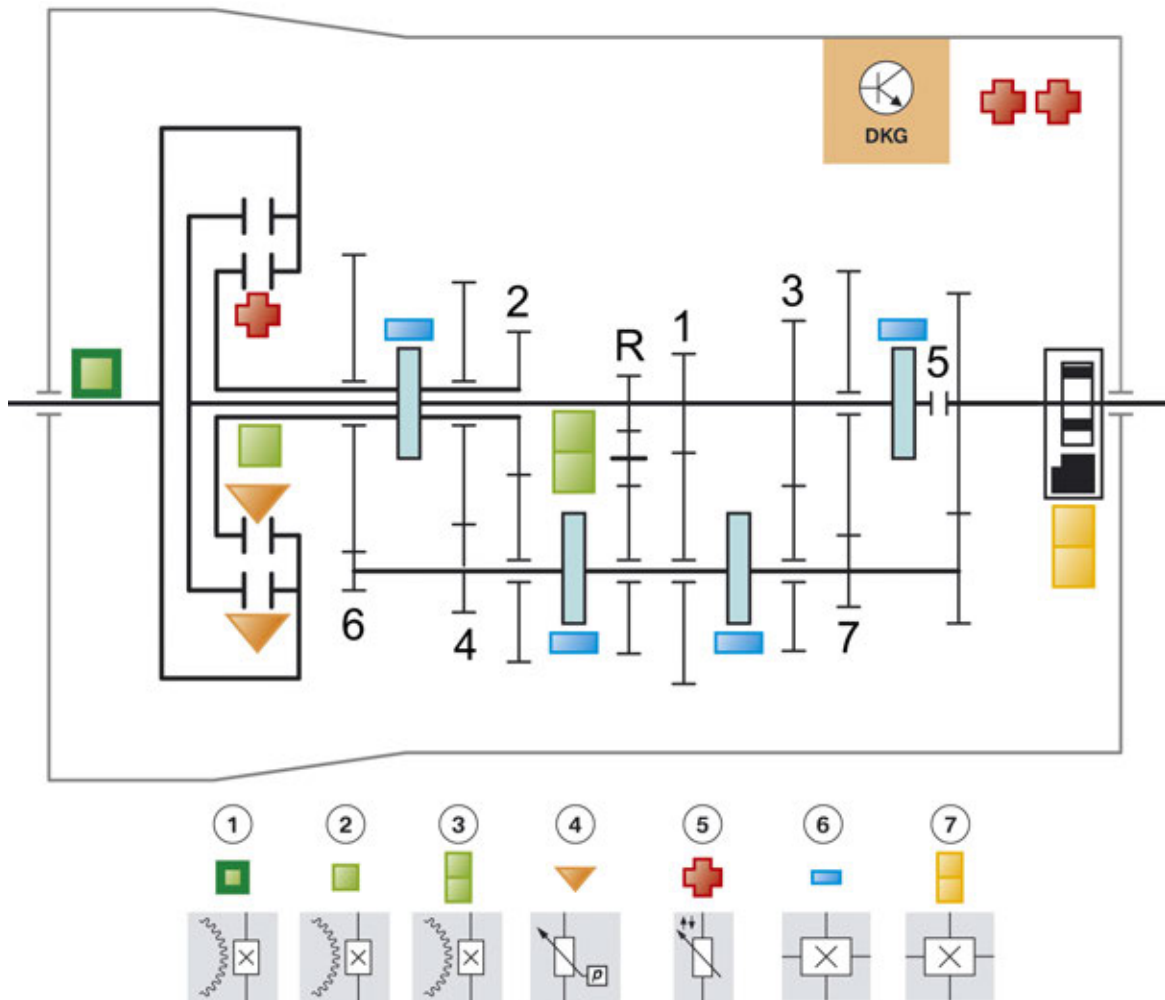

F80/F82 M DCT, schematic diagram of inner sensor system

TA11-0993

Index	Explanation
1	Input speed hall effect sensor
2	Transmission input speed hall effect sensor of the inner input shaft 2
3	Transmission input speed hall effect sensor with detection of direction of rotation of inner input shaft 1
4	Clutch oil pressure Piezo sensors
5	Temperature NTC sensors
6	Shift travel hall effect sensors
7	Parking lock hall effect sensor (redundant)

F80/F82 Complete Vehicle

4. Powertrain

4.2.7. M gear selector switch

The functional structure and the operation of the M gear selector switch are identical to those in F1x M and F06 M6 vehicles with M DCT Drivelogic.



F80/F82 M DCT Drivelogic gear selector switch and driving dynamics button

Index	Explanation
1	DSC button (with M dynamic mode)
2	Engine dynamics button
3	M gear selector switch
4	M DCT Drivelogic button
5	Servotronic button
6	M sports suspension button (EDC)

4.2.8. Drivelogic

The number of driving programs is the same as that in F1x M and F06 M6 vehicles. However the design of the Drivelogic button has changed. Instead of a rocker type button (as the E9x M3 and for F1x M vehicles), the F80/F82 uses a normal pressure switch for clicking through the programs.

After each change between sequential mode and Drive mode the last selected driving program is active.

After each engine start driving program 1 is active in Drive mode.

Drive mode

Three driving programs are available:

- 1: Efficient drive
- 2: Relaxed drive
- 3: Sporty drive

F80/F82 Complete Vehicle

4. Powertrain

Sequential mode

Three driving programs are also available here:

1: Comfortable gear shifts.

2: Sporty, fast gear shifts.

3: Maximum shift speed and the requirement for the activation of the launch control.

To use the highest, i.e. the third driving program, the DSC does not have to be activated.

4.2.9. Launch Control

Launch Control enables optimal acceleration when driving off on a smooth roadway.



During the first 5,000 km (3,100 miles) the launch control should generally not be used (see also the chapter on driving tips in the Owner's Manual).

The 2,000 km (1,242 miles) pre-delivery check must have been completed and reset/confirmed with the Integrated Service Technical Application (ISTA) (do not reset via the instrument cluster service function, as otherwise the launch control is not enabled).

Premature wear occurs as a result of the high load of the vehicle with use of the launch control.

Launch mode preconditions

Sequence	Precondition/Action
1	The vehicle must be stationary, the engine running and at operating temperature (about 10 km (6 mile) warm-up journey).
2	The DSC is deactivated.
3	The sequential mode and the third Drivelogic driving program are selected.
4	The brake pedal is gently pressed with the left foot.
5	The accelerator pedal is pressed fully and held in this position.
6	In the M instrument cluster a flag symbol must appear (if not, check notes and steps 1-5).
7	An engine speed for pulling away of about 3500 rpm is set, which can be modified up or down in the cruise control settings by a maximum 500 rpm in 100 rpm increments.
8	The left foot is taken off the brake within 3 seconds.

F80/F82 Complete Vehicle

4. Powertrain

Effect

- The Launch Control shifts up to 5th gear independently with the shortest possible shifting times and enhanced driving performance shift points as long as the driver has the accelerator pedal pressed in fully and a time limit of 22 seconds is not exceeded for the acceleration.
- The start flag in the instrument cluster remains active.

Automatic deactivation

- The driver releases (also if only temporary) the accelerator pedal full load position during acceleration or the acceleration phase reaches a duration of 22 seconds.

If even one of these preconditions is not met, it is not possible to activate the Launch Control.

Also at excessive transmission oil temperature (e.g. repeat Launch Control or race-like start), activation is not allowed and locked until an acceptable temperature threshold is reached.

The start flag goes out with every deactivation and the automatic forced upshift is cancelled.

4.2.10. Transmission control unit

The M DCT control unit is installed in the mechatronics module in the transmission similar to the GS7D36SG.

The software is adapted to the F80/F82.

4.2.11. Emergency gearbox release



The emergency gearbox release is deleted as of 03/13, similar to the F10, F12, F13 and F06. For towing away please observed the information in the Owner's Manual of the vehicle.

F80/F82 Complete Vehicle

4. Powertrain

4.2.12. Service information

Transmission oil circuit

When work is required on the oil circuit of the DCT (regardless if it is the M DCT or AG DCT), for example after an accident, or if the oil circuit has to be opened due to a repair, there must be maximum cleanliness. This includes:

- Thoroughly cleaning the outer oil circuit areas before disassembly of the components or opening the oil circuit.
- All openings and lines must be closed immediately after disassembly with clean original plugs. Do not use unsealed components or replacement parts of the oil circuit without checking for cleanliness.
- The workbay at which a M DCT is opened must be extremely clean and secured against dirt contamination, also during work interruptions. For example by covering with a clean and lint-free cover.

Lifetime oil filling

Similar to the E9x M3 and F1x M5/M6 with M DCT Drivelogic, **no** transmission oil change is currently planned at 2,000 km/ 1200 miles (pre-delivery check) or every third engine oil change.

Repair/Part exchange

Depending on the type of repair, the data status of the M DCT must be read out beforehand and read in again after the component has been replaced (e.g. replacement of mechatronics module).

Depending on the type of repair (e.g. dual clutch change), the "Neutral" gear selection position must be selected before the engine is stopped.



The current information and specifications in the documents in the Integrated Service Technical Application (ISTA) must be observed in each case.

F80/F82 Complete Vehicle

4. Powertrain

4.3. Driveshaft

For the first time a one-piece carbon driveshaft is used in a BMW M vehicle. Traditionally steel or aluminum driveshafts are required for a vehicle designed for high performance. In order to be able to transmit the torque and engine speeds they are designed as a two-piece component and have a center mount. Only this design ensures high-speed performance, "critical bending speed". The tube element of the new M3/M4 Coupe carbon driveshaft enables a one-piece design due to its specific material properties. High rigidity was achieved with the tubular design of the driveshaft and the low density of the carbon material used in its fabrication. In addition, the legally mandated safety requirements were able to be integrated in the design.

The significant weight saving along with excellent rigidity was able to be realized by using low material density of carbon and eliminating the center mount.

In addition other desired requirements, such as corrosion resistance, low length compensation and enhanced comfort (oscillation acoustics) can be satisfied with the use of the carbon driveshaft.

In comparison to the predecessor driveshaft in the E9x M3, the weight was able to be reduced by 5.3 kg/11.6 lbs to 7.6 kg/16.7 lbs.

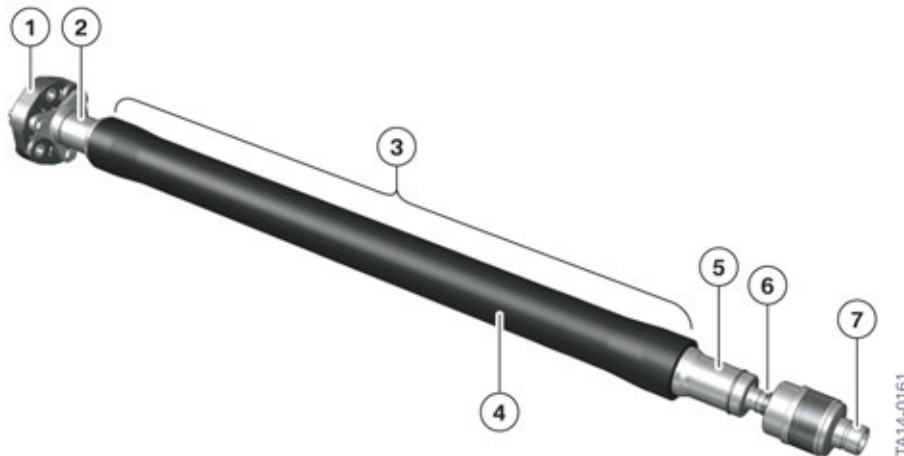

F80/F82 carbon driveshaft

Index	Explanation
1	Flexible disc joint
2	Pipe adapter, front
3	Support ring
4	Carbon pipe
5	Pipe adapter, rear
6	Sliding piece
7	Flange, rear axle differential

F80/F82 Complete Vehicle

4. Powertrain

4.3.1. Service information

- During disassembly ensure that the carbon driveshaft is removed first at the rear (at the sliding piece) and then at the front carrier (flexible disc). The installation should be done in the reverse sequence.
- In the sliding piece there is a grease filling, which is coordinated precisely to requirements and is required for the function. Therefore, do not remove the grease cap before the driveshaft is pushed together for the installation at the sliding piece. Remove the grease cap after the pushing together and then screw the driveshaft at the rear axle differential.
- Please check the U-type bellows again after pushing together. The U-type bellows should not arch outwards, bend back if necessary.



The carbon driveshaft is highly sensitive to impacts, therefore the driveshaft should not be stored in an upright position. The carbon driveshaft should be stored in a horizontal position or suspended. Also during this storage period keep the carbon driveshaft away from impacts.

A clear indicator protective layer (woven fabric) is attached to the carbon driveshaft. If the carbon driveshaft was subjected to an impact, small cracks in the form of a spider web appear on this layer. Damage can be identified by means of this crack and the necessary measures deduced from a damage pattern catalog in the Integrated Service Technical Application (ISTA).

The current information and specifications in the documents found in the Integrated Service Technical Application (ISTA) must be observed in each case.

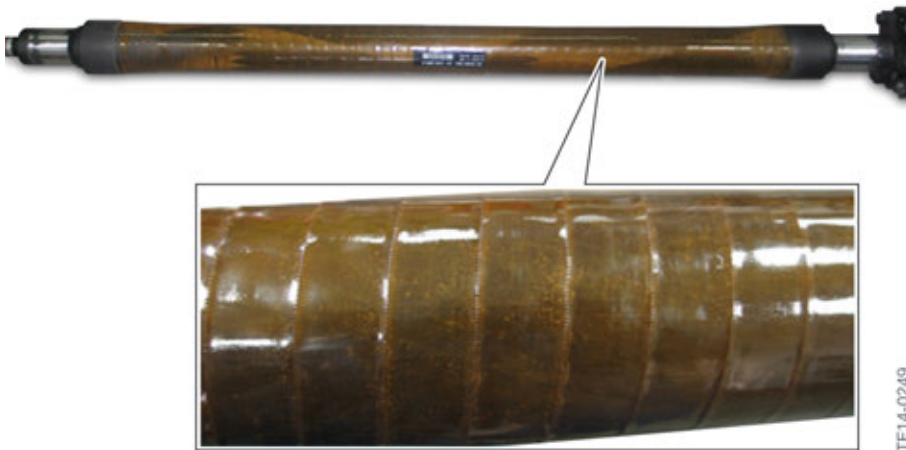

F80/F82 carbon driveshaft, indicator layer

4.4. Rear axle final drive

4.4.1. Active M Differential

This electronically/electromechanically controlled rear axle differential lock was developed especially for the F10 M5, it is used in the F06/F12/F13 M6 and now in the F80/F82.

F80/F82 Complete Vehicle

4. Powertrain

The M rear axle differential, size HAG 220 (ring gear \varnothing 220 mm), is used with a M rear axle differential lock. The system designation for this is "regulated rear axle differential lock", the control unit designation is GHAS (**G**eregelte **H**inter **A**chsgetriebe **S**perre (regulated rear axle differential lock).

This variable M differential lock II replaces the variable M differential lock I in the M rear axle differential HAG 215 (ring gear \varnothing 215 mm) used in the E9x M3.

The gear ratio of the HAG 220 is 3,154:1 (HAG 215: 3,615:1).

This M rear axle differential can be recognized by an aluminum oil sump assembled from below and an electric motor which is visible from the outside.

The HAG 220 is about 2.8 kg/6 lbs heavier than the HAG 215 at 49.7 kg/109 lbs.

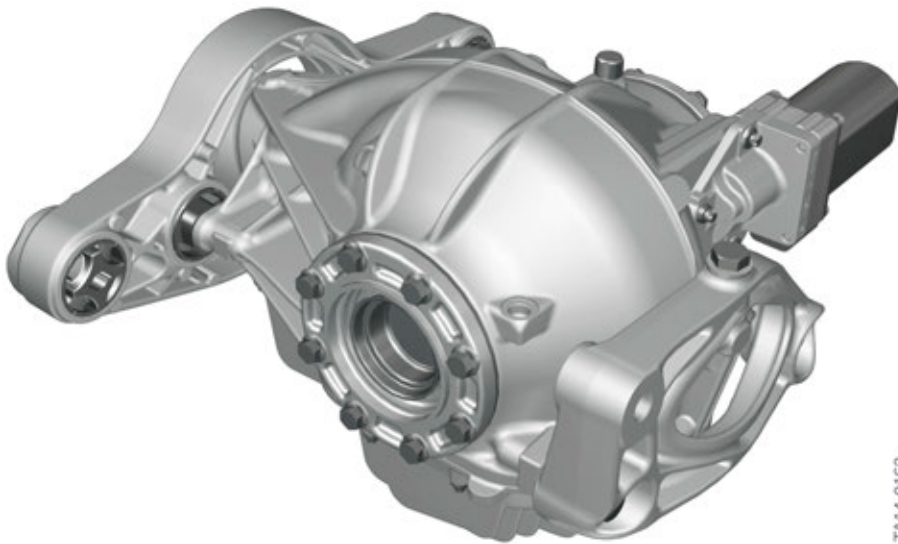

F80/F82 GHAG, external view

Demand-controlled lock

The lock is a demand-controlled rear-axle differential lock which is active in the following situations:

- Pulling away.
- Differential speed at the rear axle for straight-ahead driving under tension due to various coefficients of friction, left/right.
- Dynamic cornering tensioned.
- Power oversteer (drifting).
- Stabilization in coasting/overrun mode.

Traction, handling and driving stability are enhanced by adjusting a defined differential speed or differential torque at the rear axle.

The regulated M rear-axle differential lock works with a position-controlled electric motor and a ball ramp. The GHAS control unit is installed above the Rear Electronic Module (REM), at the rear right inner fender.

F80/F82 Complete Vehicle

4. Powertrain

4.4.2. Structure/Function

The lock-up torque is generated by a multi-disc clutch. The necessary axial pressure is applied to the multi-disc clutch by the position-controlled direct current motor by means of gears and a ball ramp mechanism. The clutch package operates between the differential housing (steel outer discs) and the right output (molybdenum-coated steel inner discs).

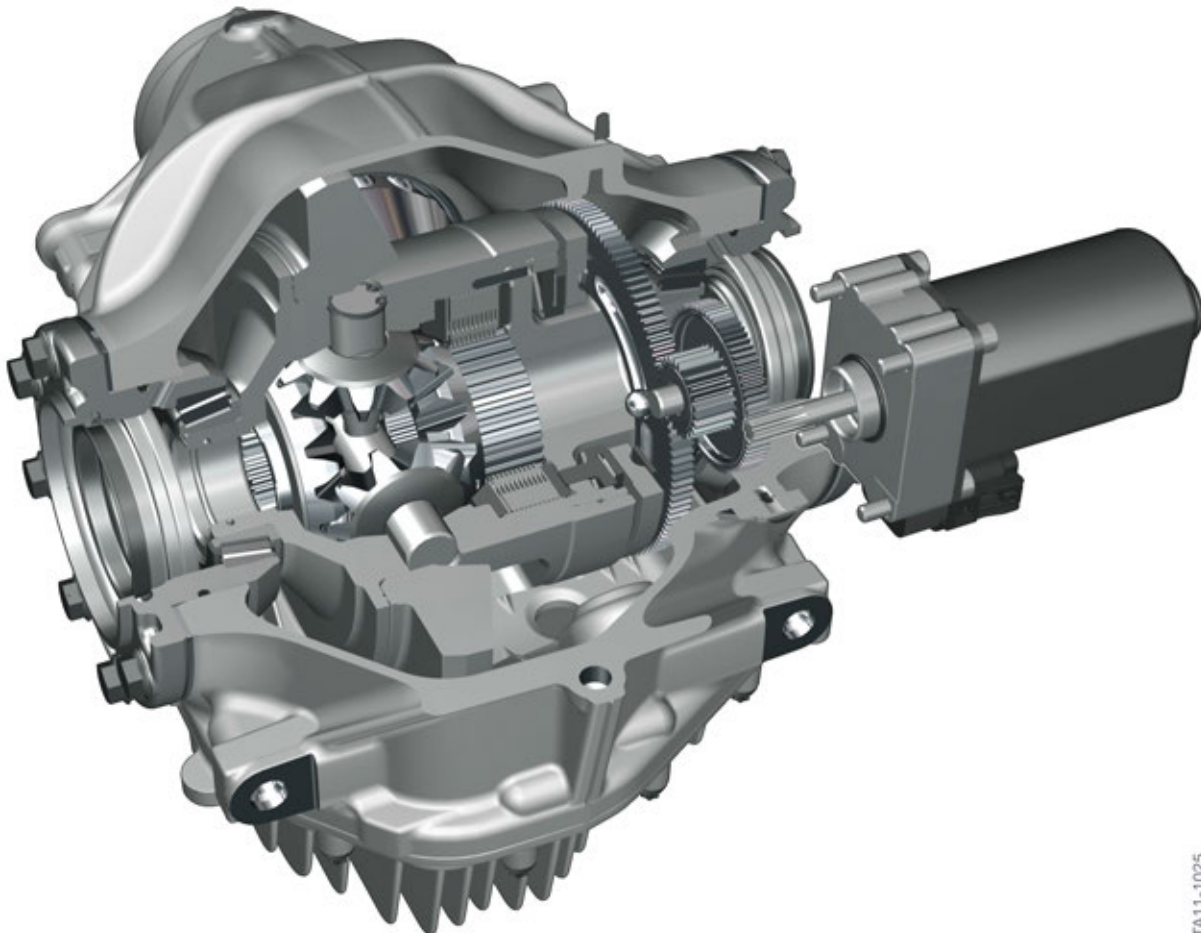

TA11-1025

F80/F82 rear axle differential, section view

System components:

- Wiring harness
- Regulated differential lock control unit (GHAS)
- Electric motor and transmission gearing
- Lock

F80/F82 Complete Vehicle

4. Powertrain

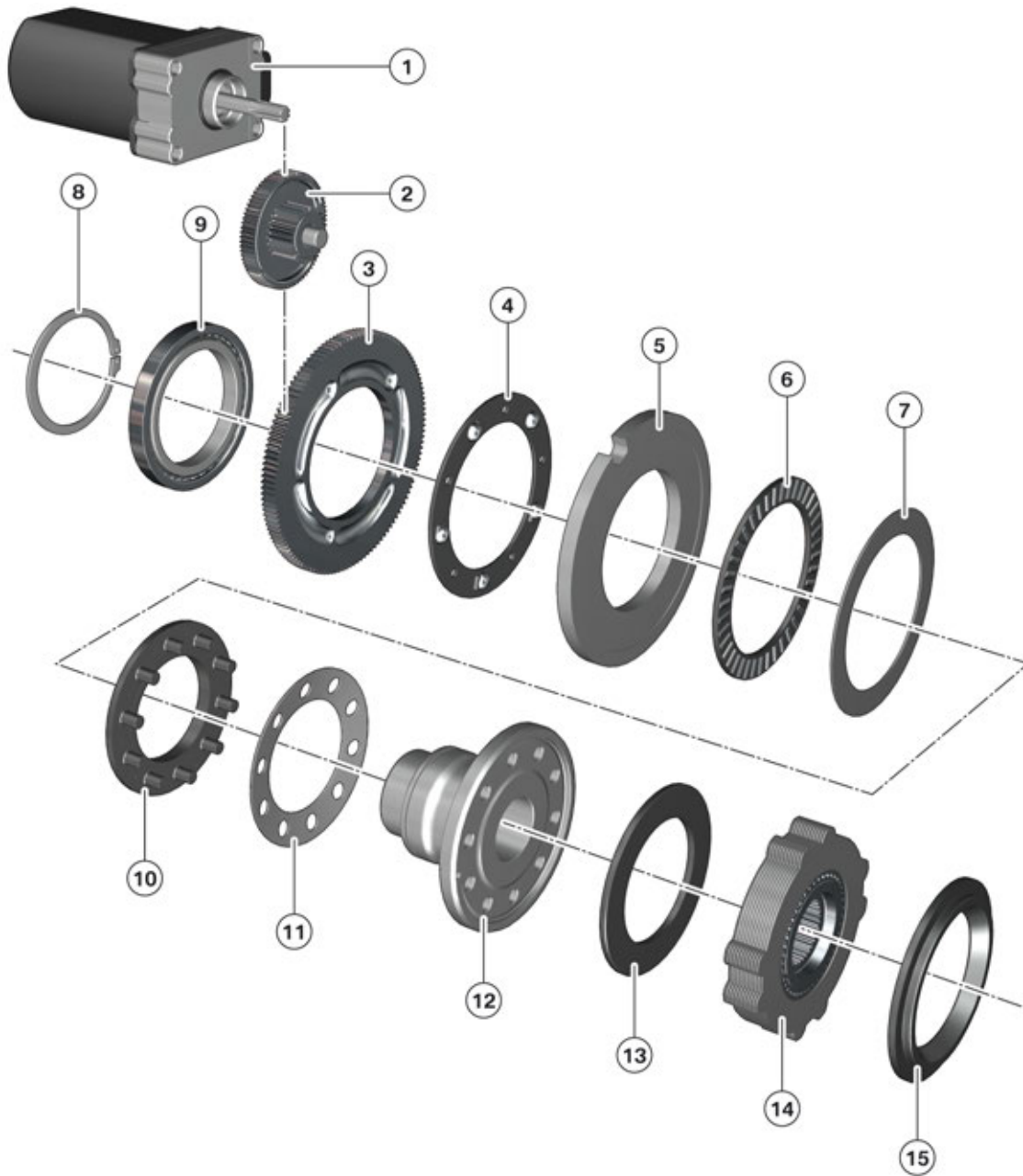

TA11-1021

F80/F82 components of the locking differential: Exploded diagram

Index	Explanation
1	Electric motor
2	Intermediate gear
3	Ball ramp consisting of geared mobile adjusting disc and first half of ball ramp
4	Balls/Spherical washers
5	Fixed pressure disc with second half of ball ramp
6	Axial needle bearing

F80/F82 Complete Vehicle

4. Powertrain

Index	Explanation
7	Axial bearing thrust washer
8	Circlip (ball bearing fixing)
9	Ball bearing between inner output hub and differential housing
10	Disc spring pressure ring
11	Diaphragm spring
12	Differential lid (connected to differential housing, cannot rotate)
13	Pressure plate
14	Disc set
15	Counter pressure plate

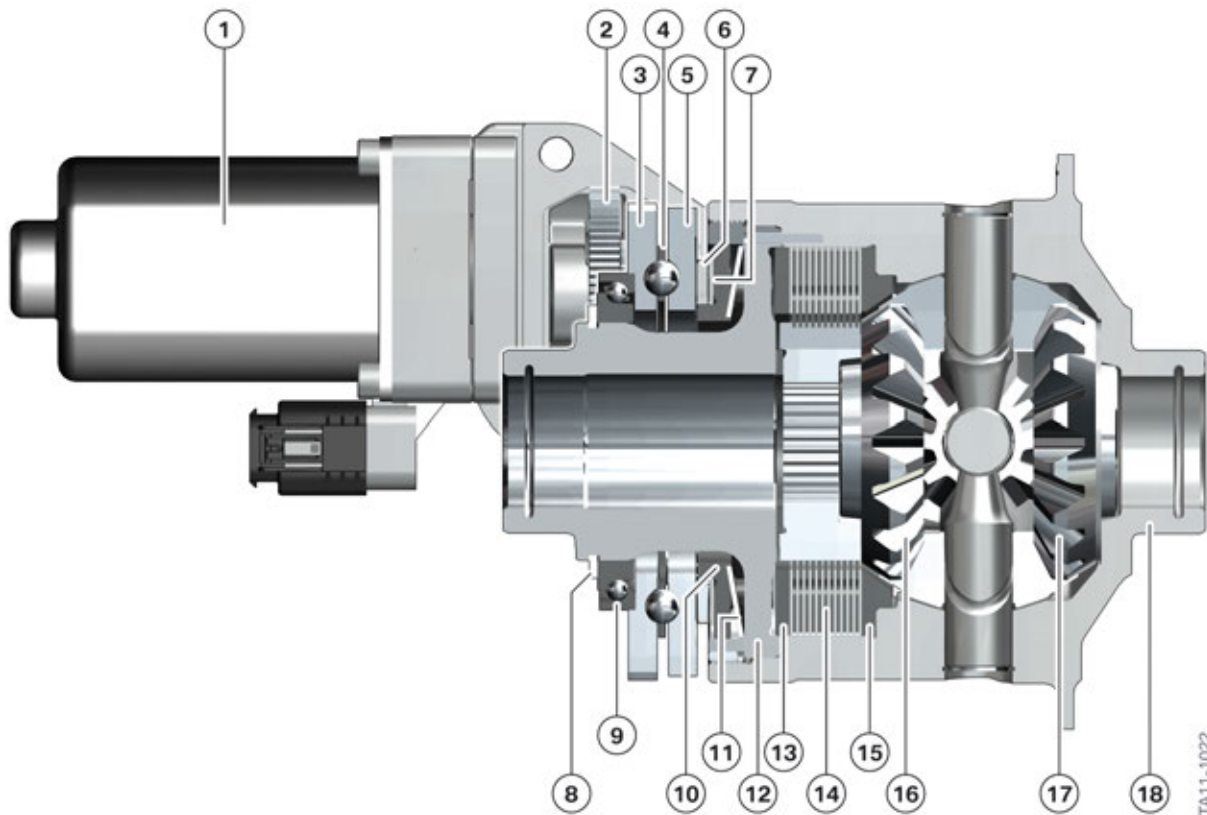

F80/F82 Locking Differential, section view

Index	Explanation
1	Electric motor
2	Intermediate gear
3	Ball ramp consisting of geared mobile adjusting disc and first half of ball ramp
4	Balls/Spherical washers
5	Fixed pressure disc with second half of ball ramp

F80/F82 Complete Vehicle

4. Powertrain

Index	Explanation
6	Axial needle bearing
7	Axial bearing thrust washer
8	Circlip (ball bearing fixing)
9	Ball bearing between inner output hub and differential housing
10	Disc spring pressure ring
11	Diaphragm spring
12	Differential lid (connected to differential housing, cannot rotate)
13	Pressure plate
14	Disc set
15	Counter pressure plate
16	First output bevel gear
17	Second output bevel gear
18	Differential housing (connected to outer discs)

The electric motor (1) is bolted on to the housing and the pressure disc fixed to the second ball ramp half (5) in the housing. The mobile components of the ball ramp (2, 3 and 4) generate the necessary axial displacement of the pressure disc (5). These components are not subject to the differential transmission rotation and are disconnected from the rotating components by an axial needle bearing (6).

The components with the index 6 to 18 belong to the differential and rotate proportional to the rear axle gear speeds.

The locking is done between the right output (16) and the differential housing (18) and counteracts a difference in speed between the output bevel gears (16 and 17). The disc spring (11) opens the lock when the engine is not supplied with current.

4.4.3. System information

The GHAS control unit evaluates the dynamic handling characteristics parameters made available by other control units via the FlexRay data bus and determines the lock-up torque to be applied. The DSC control unit can also request separate and higher-level locking interventions to stabilize the vehicle both when the DSC is activated and deactivated.

The position-controlled direct current motor is activated directly by the power electronics of the GHAS control unit with vehicle voltage via a pulse-width-modulated signal. The frequency is 12.8 kHz and the maximum current level is 30 A.

The electric motor is equipped with two hall effect sensors to determine its position and the direction of rotation.

F80/F82 Complete Vehicle

4. Powertrain

System wiring diagram

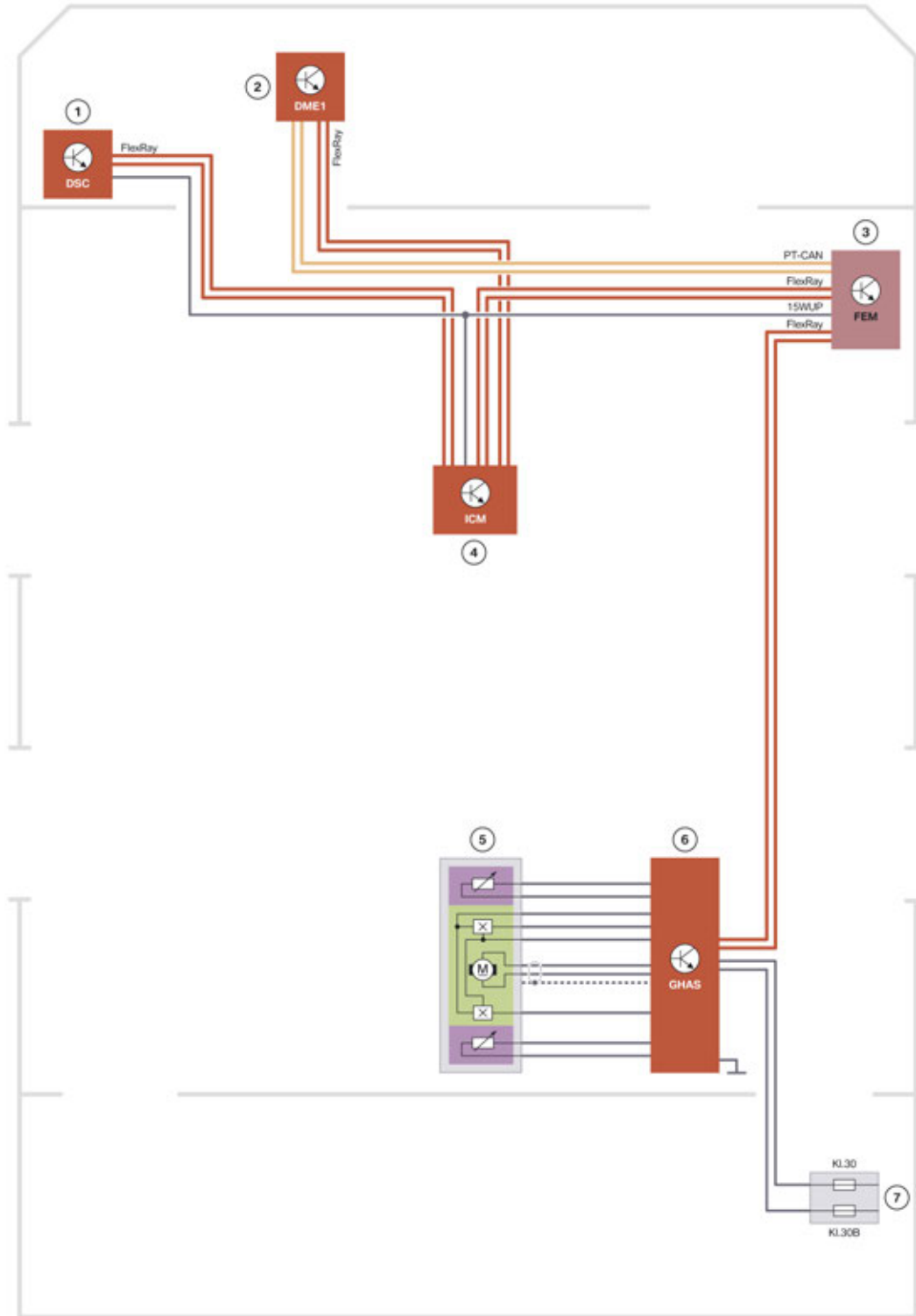

TE14-0163

F80/F82 GHAS, system wiring diagram

F80/F82 Complete Vehicle

4. Powertrain

Index	Explanation
1	Dynamic Stability Control (DSC)
2	Digital Motor Electronics (DME)
3	Front Electronic Module (FEM)
4	Integrated Chassis Management (ICM)
5	Components of the regulated rear axle differential lock
6	Control unit of the regulated rear axle differential lock (GHAS)
7	Power distribution box, rear

Interfaces

The regulated differential lock (GHS) control unit works with the following control units and includes the following information:

Control unit	Bus system	Information
FEM		<ul style="list-style-type: none">- Terminal status- Vehicle identification number (for encoding)- Vehicle condition (power management and fault memory block, e.g. in the event of voltage drop by engine start)
DME	PT-CAN/FlexRay	<ul style="list-style-type: none">- Accelerator pedal angle- Wheel drive torque- "Engine running" signal
DSC	FlexRay	<ul style="list-style-type: none">- Wheel speed- Setpoint axial torque distribution- Stabilization status- Brake value
ICM	FlexRay	<ul style="list-style-type: none">- Tolerance adjustment of wheel (adjustment of different wheel circumferences)- Lateral acceleration- Yaw rate- Driving speed- Road longitudinal tilt- Steering angle
FEM-ZGM	Gateway for all bus systems	Forwarding of information to regulated differential lock

Electric motor location determination

To determine the position of the electric motor two hall effect sensors in the motor are evaluated.

To determine the characteristic curve of the lock-up torque via the motor position a re-calibration is regularly performed to compensate for the wear in the clutch.

F80/F82 Complete Vehicle

4. Powertrain

In order to be able to assign a corresponding clutch lock-up torque to a certain position of the servomotor, and to take wear influences into consideration, every 1000 km (621 miles) or after an energy input in the lock of 100 kJ (corresponds to a lap of the Nürburgring) a reference run is performed after the engine is shut down. During this reference run the motor is subjected to a defined current level. The lock-up torque 1500 Nm (1106 lb-ft) is assigned to the resulting position.

Temperature monitoring

Three temperature sensors are installed. The temperature of the control unit (driver output stage), the temperature of the electric motor and the transmission oil temperature are monitored.

The temperature thresholds are as follows:

Control unit 105 °C (221 °F)

Electric motor 160 °C (320 °F)

Oil temperature 190 °C (374 °F)

The current oil specification is "BMW final drive oil synthetic MSP/A" (for e.g. Castrol SAF-XJ) and is the same oil used in the previous M vehicles with variable M differential lock.

The capacity is currently 1.2 l (1.27 qt). The current specification in our service information "Operating materials" and the technical data in the Integrated Service Technical Application (ISTA) must be observed in each case.



If, due to a fault, the GHAS lock function is switched off or fails, a locked differential is automatically reopened as the lock function is not self-locking. The driver is warned and informed regarding the effects that can be expected:

1. Loss of traction with dynamic driving style and low coefficients of friction, particularly with different coefficients of friction, left/right.
 2. Possible deterioration of stability in dynamic driving situations.
-

4.4.4. Service information

- For a replacement of the GHAS control unit an encoding (activation of vehicle-related characteristic curve) and then an initial calibration are necessary and then the fault memory must be deleted.
- After the replacement of the entire M rear axle differential a calibration must be performed and then the fault memory must be deleted.
- For a replacement of the electric motor, electric motor plus intermediate gear or oil temperature sensor, only the fault memory must be deleted.

The final drive oil is currently replaced at 2000 km/1200 miles (pre-delivery check) and at every third engine oil change.



The current information and specifications in the Integrated Service Technical Application (ISTA) must be observed.

F80/F82 Complete Vehicle

4. Powertrain

4.4.5. Half-shafts

As is typical for BMW M vehicles, the output shafts have a hollow design in order to make optimal use of the material in relation to material usage, weight and rigidity.

These lightweight half-shafts are designed to transmit up to 7000 Nm (5163 lb-ft) torque.

The CV joints and the trunnion mounts of the F80/F82 are drilled hollow. This is the first time this intelligent lightweight construction was implemented in a M vehicle.

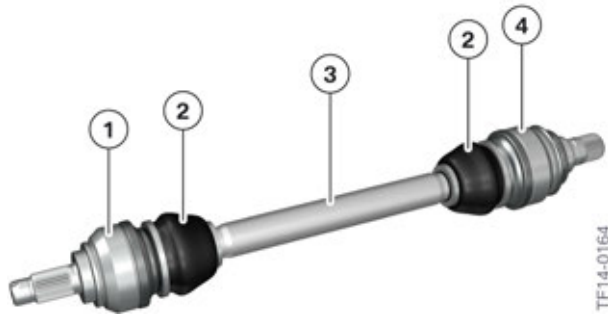

F80/F82 output shaft

Index	Explanation
1	CV Joint drilled hollow on the wheel-side with trunnion mount
2	Boot
3	Hollow shaft
4	CV Joint drilled hollow at the rear axle differential with trunnion mount

The special feature of the output shafts is the double-sided gearing. They are no longer flange-mounted at the rear axle differential and inserted in the wheel hub, but are inserted in the rear axle differential and in the drive flange. The procedure has thus changed for installation and removal.



The current information and specifications in the Integrated Service Technical Application must be observed.

F80/F82 Complete Vehicle

4. Powertrain

4.4.6. Wheel flange

The intelligent lightweight construction was also implemented with regard to the wheel flanges of F80/F82.

The wheel flange at the front axle and the rear axle have been enhanced in relation to their weight. The material has been reduced at places subject to little stress, and accumulated at heavily stressed places.

With these measures provide a weight saving of about 1.13 kg / 2.5 lbs in comparison to the E9x M3.

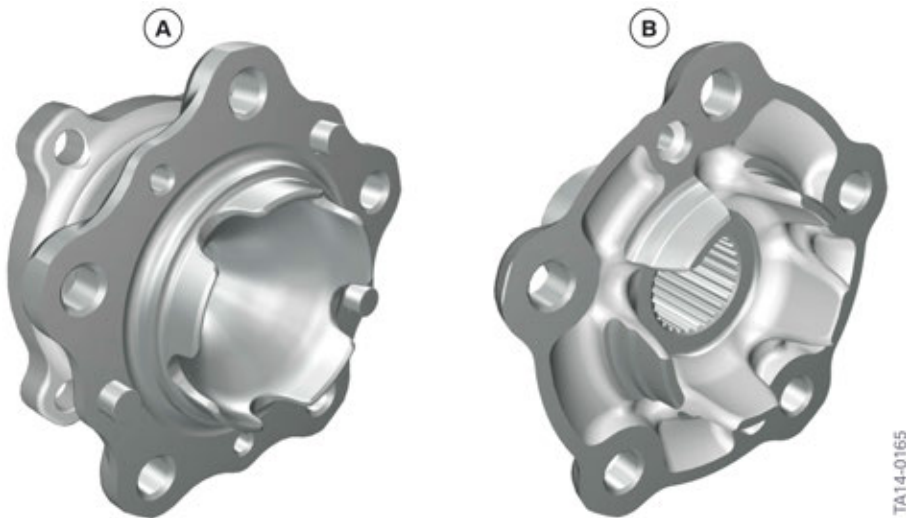

F80/F82 wheel flange

Index	Explanation
A	Wheel bearing unit with front wheel flange
B	Drive flange, rear

F80/F82 Complete Vehicle

5. Chassis and Suspension

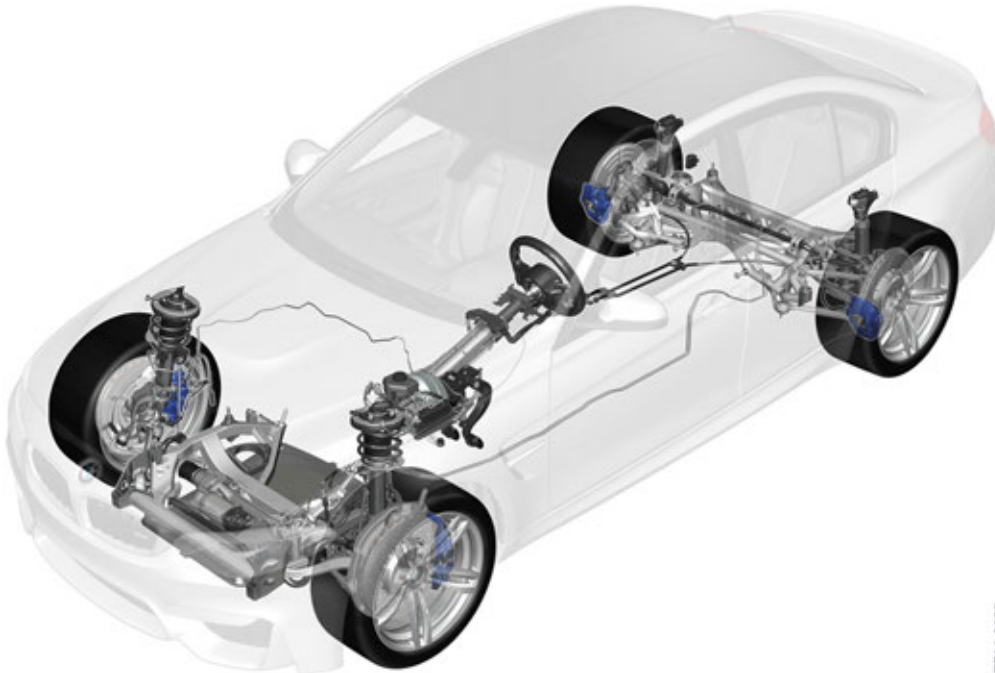

TF14-0166

F80/F82 chassis and suspension, complete

The chassis and suspension is based on the technology of the F3x and the E9x M3, whereby almost all components are again new and specific to M or have been adapted.

Designation	Unit	E9x M3	F10 M5	F80/F82– M3/M4 Coupe
Wheelbase/turning circle	[mm/m]	2761/11,7	2964/12,4	2812/12,2
Front track width	[mm]	1540	1627	1579
Rear track width	[mm]	1539	1582	1603
Front Axle		M two-joint spring-strut front axle	M double- wishbone axle	M two-joint spring-strut front axle
Steering		Hydraulic M rack-and-pinion steering with M Servotronic	Hydraulic M rack-and-pinion steering with M Servotronic	Electrical rack-and- pinion steering (EPS) with M Servotronic
Average overall ratio		12,5	13,05	15
Steering wheel turns End stop-end stop		2,4	2,6	2,5
Rear axle		M 5–joint rear axle	M Integral IV (based on E60 M5)	M 5–joint rear axle
Axle ratio		3.154	3.154	3.462

F80/F82 Complete Vehicle

5. Chassis and Suspension

5.1. Front Axle

The front axle is based on the M two-joint spring strut front axle of the E9x M3. All components or the bearings are new to M or have been adapted and the M front axle support has been reinforced with a stiffening plate, typical of M.

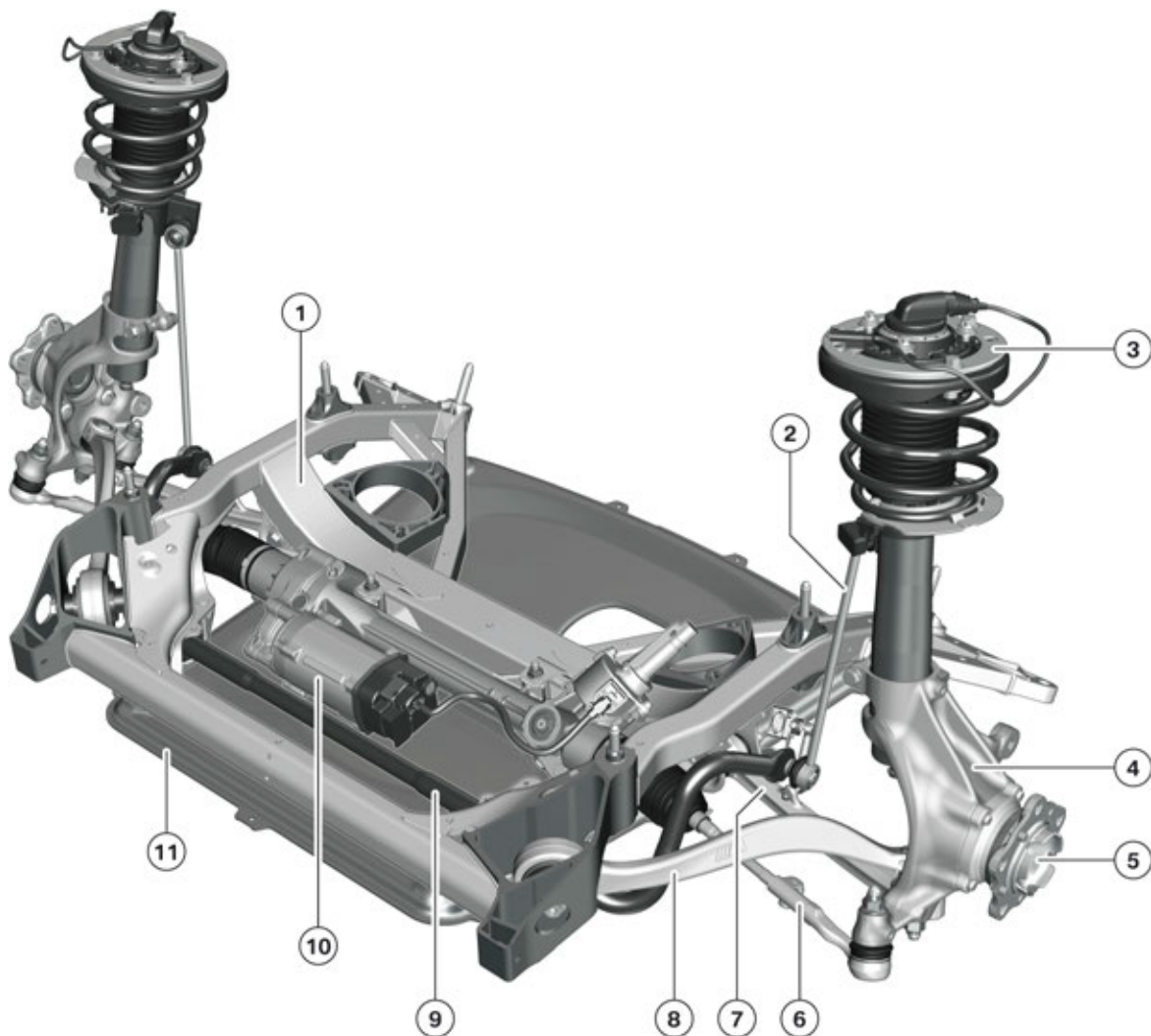

TF14-0167

F80/F82 two-joint spring strut front axle

Index	Explanation
1	M front axle support
2	M anti-roll bar link
3	M spring strut with support bearing
4	M swivel bearing
5	M wheel bearing unit with wheel flange
6	M track rod

F80/F82 Complete Vehicle

5. Chassis and Suspension

Index	Explanation
7	M wishbone
8	M trailing link with hydro mount
9	M anti-roll bar
10	M Servotronic (EPS)
11	M stiffening plate

All components have been redesigned for the increased requirements. The guiding of the wheel for compression and steering is done via the wishbone, the tension strut, the spring strut and the track rod.

In order to guarantee precise wheel guiding in transverse direction of vehicle, the power is transmitted from the swivel bearing to the front axle guide via the ball joints with no play. In order to also guarantee this in a longitudinal direction, the chassis and suspension forces are transmitted via specially developed elastomer bearings for the F80/F82 via the tension struts to the front axle support.

The stiffening plate and the additional screw connections of the axle support and the side sills also ensure an increase in the transverse rigidity of the front of the vehicle by about 30%.

The connection between the spring strut and the swivel bearing was realized by a clamp connection similar to the E82 M and E9x M3.

F80/F82 Complete Vehicle

5. Chassis and Suspension

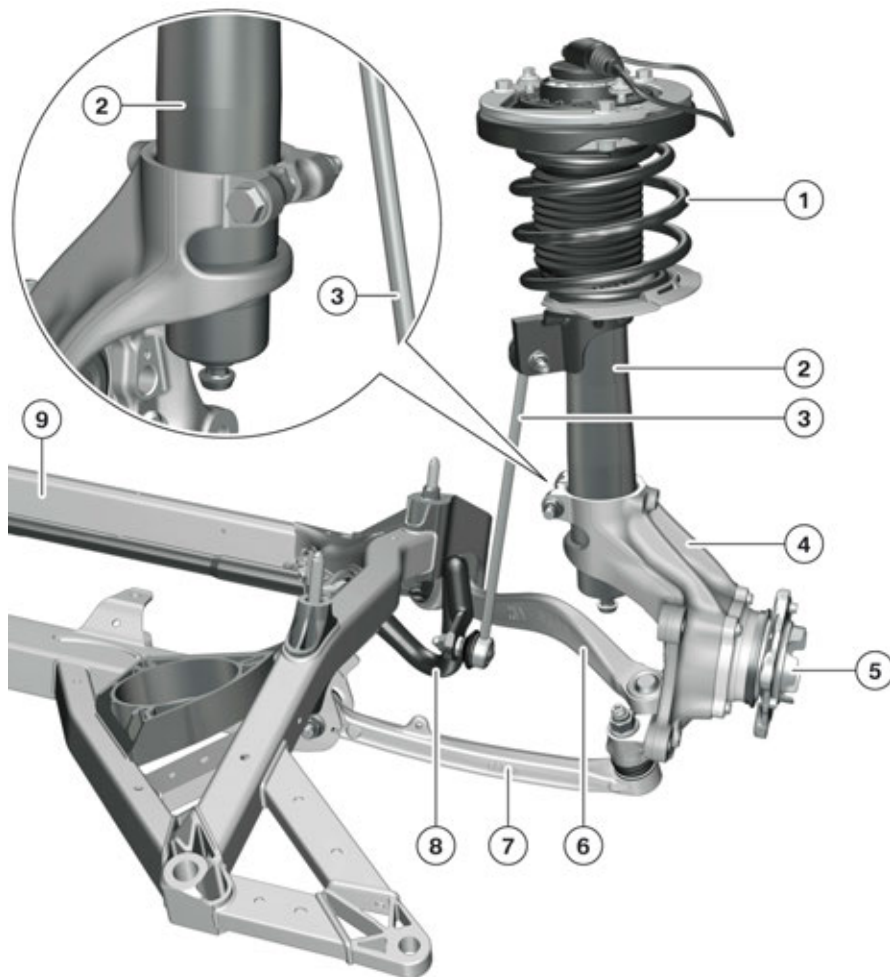

TF14-0168

F80/F82 spring strut-swivel bearing connection

Index	Explanation
1	M spring
2	M spring strut
3	M anti-roll bar link
4	M swivel bearing
5	M wheel bearing unit with wheel flange
6	M wishbone
7	M tension strut
8	M anti-roll bar
9	M front axle support

The intelligent lightweight construction of the F80/F82 also was implemented in the front axle concept. The wishbone, wheel carrier, axle support and the stiffening plate are manufactured in lightweight aluminum.

F80/F82 Complete Vehicle

5. Chassis and Suspension

A weight saving of about 5 kg / 11.0 lbs was achieved with these measures in comparison to the F3x M3.

Further weight savings were achieved with the design of the spring strut in aluminum, as well as the tubular design of the anti-roll bar (as in the E9x M3).

The design of the front axle was done in close cooperation with the tires which were also specially developed for the F80/F82.

5.1.1. Steering

EfficientDynamics measures were also implemented on the new F80/F82. The rack-and-pinion steering has electrical steering wheel support "M Servotronic based on EPS".

For power steering assistance is done via an electric motor located parallel to the steering rack housing. The power transmission is done via a ball screw design.

The use of a M Servotronic (EPS) in the new M3/M4 Coupe results in a weight saving of about 3.5 kg / 7.7 lbs in comparison to the hydraulic steering system in the E9x M3.

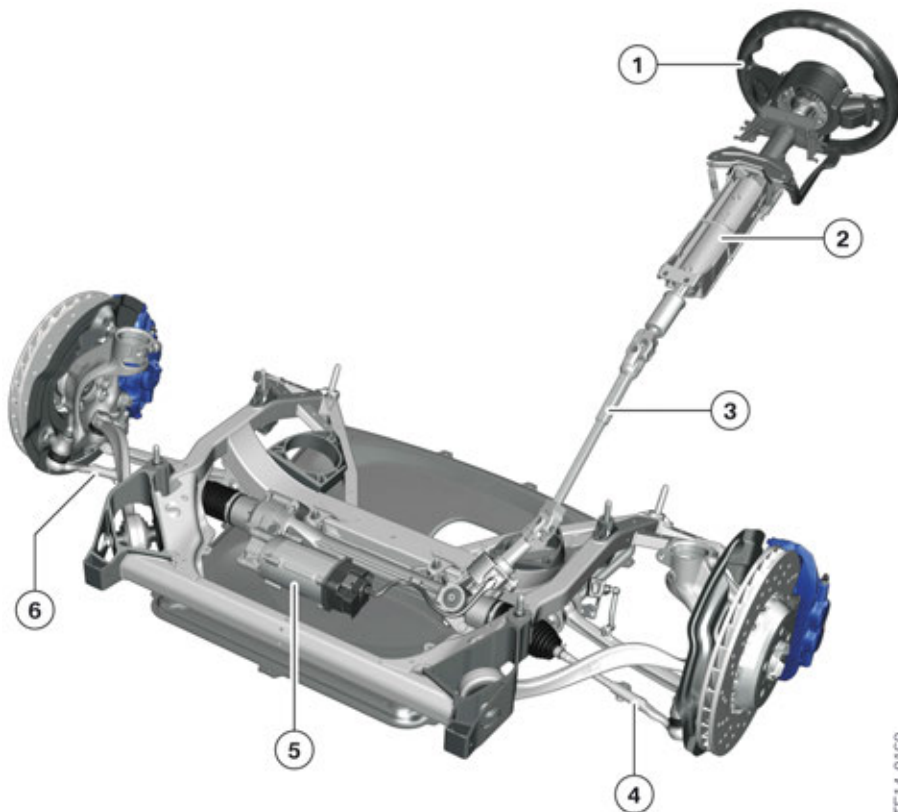

TF14-0169

F80/F82 steering

F80/F82 Complete Vehicle

5. Chassis and Suspension

Index	Explanation
1	M steering wheel
2	Adjustable steering column
3	Steering column
4	M track rod, left
5	M Servotronic (EPS)
6	M track rod, right

The M Servotronic (EPS) is an independent development for the M3/M4 Coupe. All components of the M Servotronic (EPS) have been developed specifically for the M3/M4 Coupe. The development of the steering was able to be coordinated to the typical M properties. Special attention was paid to the typical M features:

- Direct steering sensation
- Driving condition feedback
- Dynamic driving at the vehicle's stability limit

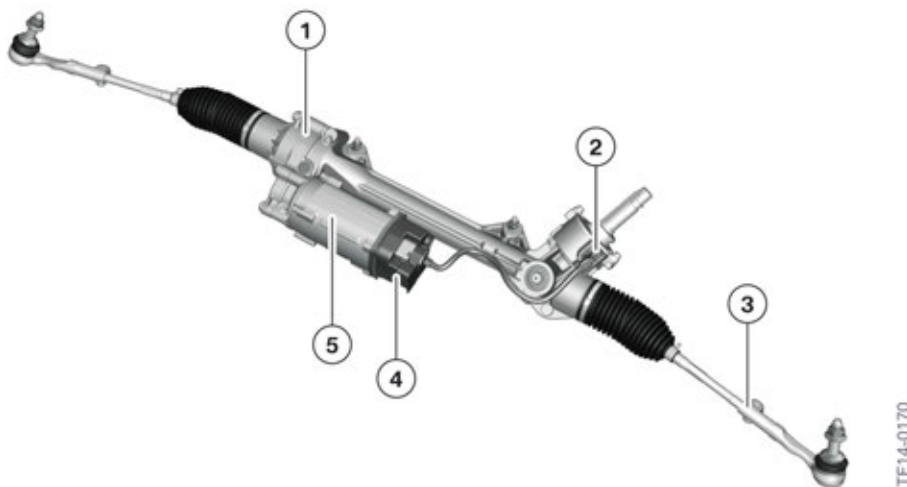

F80/F82 M Servotronic (EPS)

Index	Explanation
1	Reduction gear
2	Steering-torque sensor
3	Track rod
4	Control unit, M Servotronic (EPS)
5	Electric motor with rotor position sensor

The ratio of the M Servotronic (EPS) was also adapted to the M3/M4 Coupe. It should be highlighted that after an eighth of a revolution of the steering wheel the rack ratio increases by 8% (similar to the production vehicle F3x with the optional equipment SA 2VL Variable Sport Steering).

F80/F82 Complete Vehicle

5. Chassis and Suspension

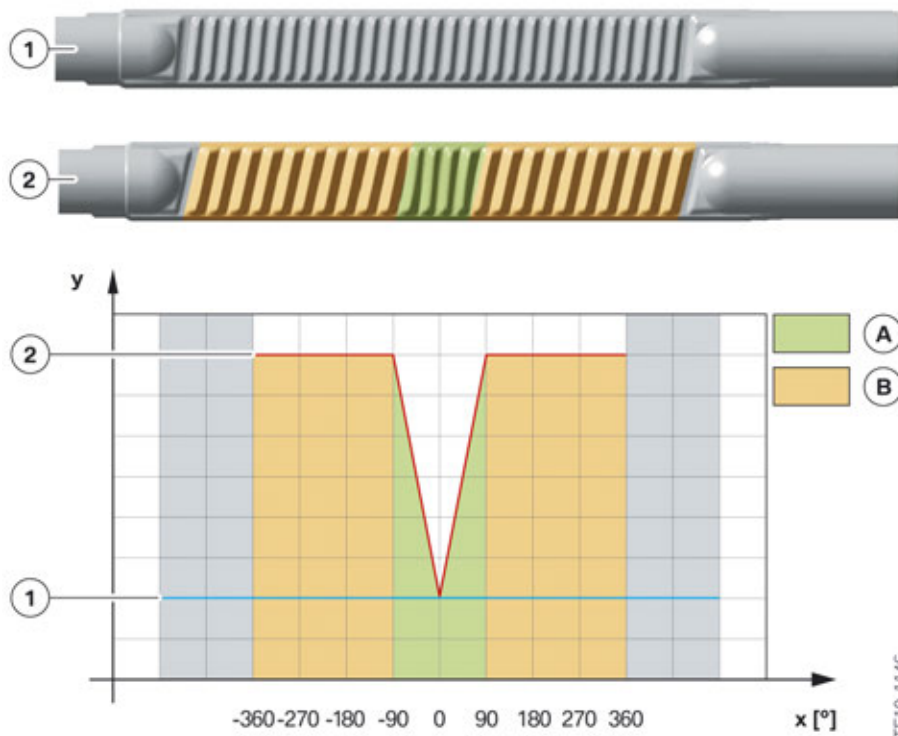

Comparison between steering gear ratio of basic M Servotronic (EPS) steering and Variable Sport Steering for F80/F82

Index	Explanation
1	Rack in basic version of F3x (constant gear geometry)
2	Variable sport steering rack (variable gear geometry)
A	More indirect steering gear ratio (variable sport steering)
B	More direct steering gear ratio (variable sport steering)
X	Steering angle
y	Rack stroke

With the use of the M Servotronic (EPS) in the new M3/M4 Coupe the parking assistance system "Parking Maneuvering Assistant" (SA 5DP) is now also offered.

5.1.2. Servotronic

The Servotronic function known from traditional hydraulic steering systems is also used in the M Servotronic (EPS) and is installed in the M3/M4 Coupe as standard. It is a M Servotronic, which functions according to the same operating principle as in production vehicles. The difference in the M Servotronic is that **three stages** can be selected in comparison to two stages in the production vehicles, and it has a separate button in the driving dynamics button panel in the center console. The button or the configuration in the MDrive menu is used to switch between "Comfort", "Sport" and "Sport+". Here the corresponding characteristic curve is activated and in Sport direction the power steering support is also noticeably withdrawn. The program selection can also be pre-configured in the MDrive menu and selected via the M button on the steering wheel assigned to the MDrive.

F80/F82 Complete Vehicle

5. Chassis and Suspension

5.1.3. Steering angle sensor

The information on the steering angle is not recorded by the Electronic Power Steering (EPS) and not via a separate sensor on the steering wheel, instead its calculated based on the motor position angle of the EPS motor in relation to the steering wheel.

The EPS transmits the position of the rack to the ICM control unit via FlexRay. During this process, the EPS calculates the absolute position of the rack based on the current motor position of the EPS motor and the number of complete revolutions performed by the motor starting from the zero position (straight-ahead driving position).

Taking this position as the starting point, the ICM control unit determines the wheel-specific steering angle among other things using the stored ratio parameters (rack to wheel-specific steering angle) and transmits this via FlexRay. This wheel-specific steering angle is used by the DSC among other things as a reference variable for internal control functions.

In cases where the absolute value is not available from the EPS (loss of Terminal 30, flash process), the absolute value is determined through interaction between the ICM and EPS using an adaptation function in which the steering wheel is turned from end stop to end stop (e.g. straight-ahead position -> left -> right -> straight-ahead position).

F80/F82 Complete Vehicle

5. Chassis and Suspension

5.1.4. System wiring diagram, M Servotronic (EPS)

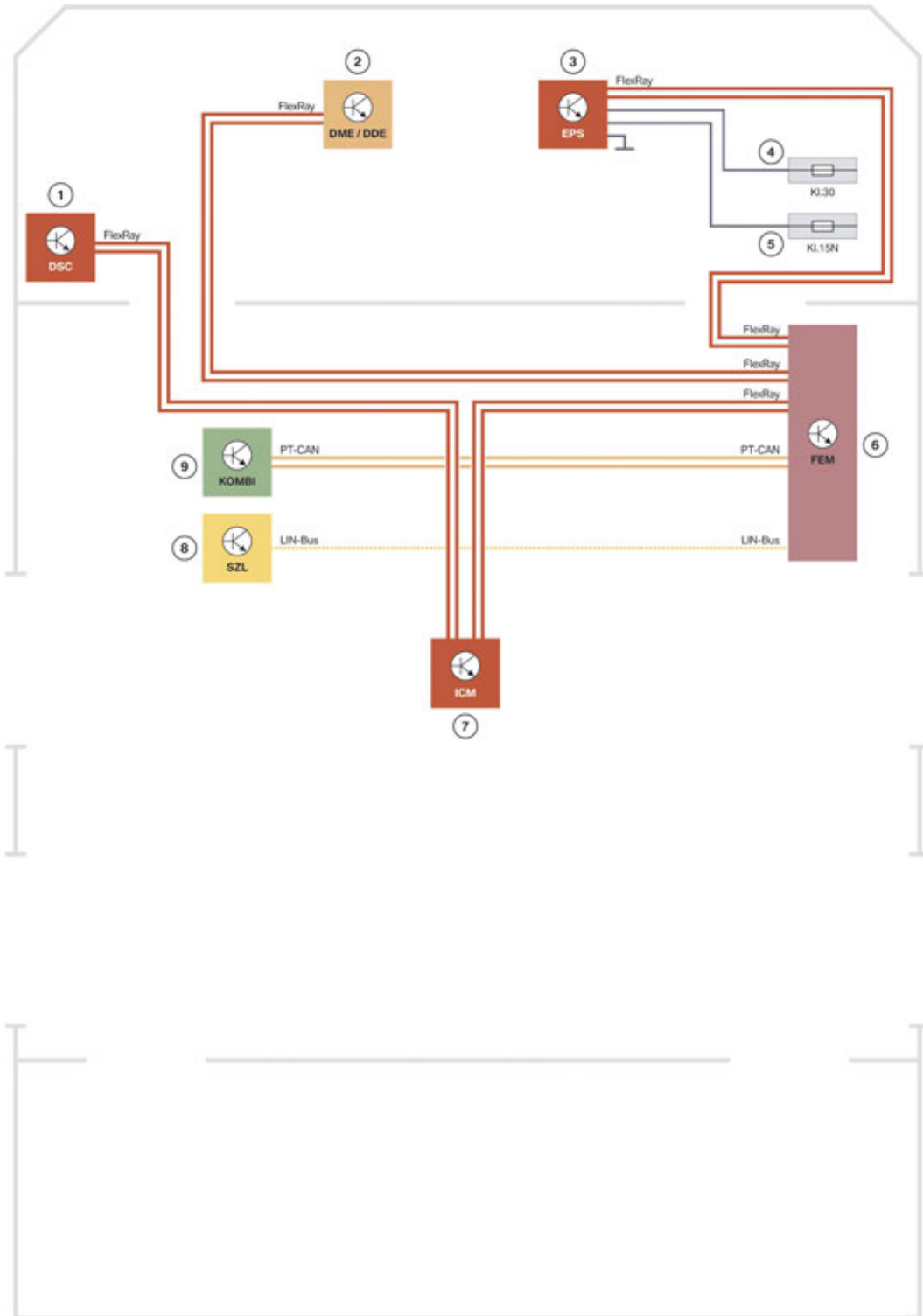

F80/F82 system wiring diagram, EPS

TE11-0041

F80/F82 Complete Vehicle

5. Chassis and Suspension

Index	Explanation
1	Dynamic Stability Control (DSC)
2	Digital Motor Electronics (DME)
3	M Servotronic (EPS)
4	Power distribution box, front
5	Power distribution box, engine compartment
6	Front Electronic Module (FEM)
7	Integrated Chassis Management (ICM)
8	Steering column switch cluster (SZL)
9	Instrument panel (KOMBI)
Terminal 15N	Ignition (after-run)
Terminal 30	Terminal 30

5.2. Rear axle

The M rear axle is based on the five-link rear axle from E9x M3. All components and bearings were redesigned for the increased requirements.

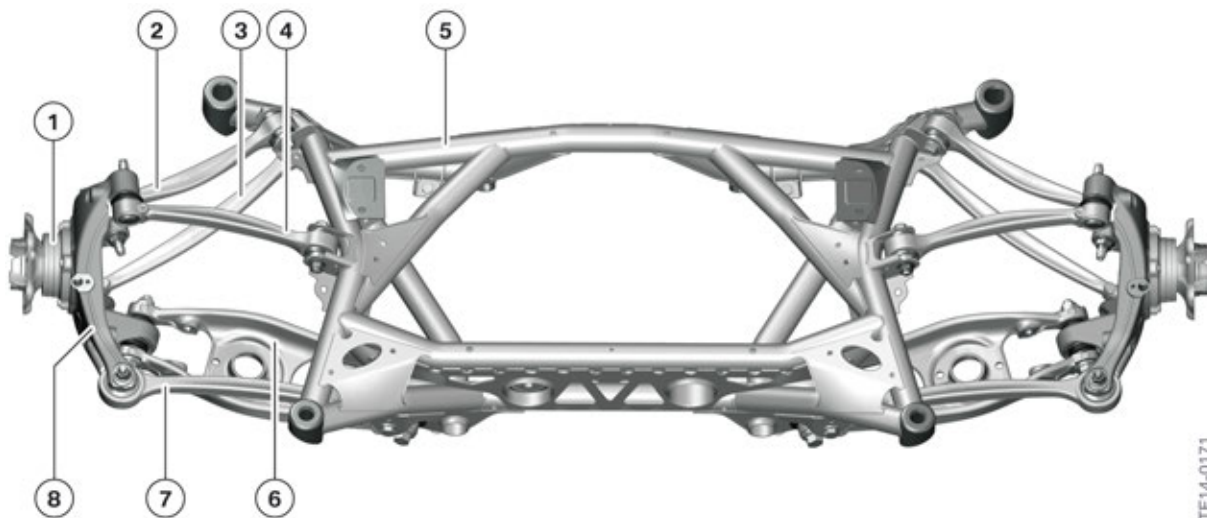

F80/F82 five-link rear axle

Index	Explanation
1	M wheel bearing unit with drive flange
2	M control arm
3	M trailing arm
4	M wishbone

F80/F82 Complete Vehicle

5. Chassis and Suspension

Index	Explanation
5	M rear axle support
6	M camber control arm
7	M track control arm
8	M hub carrier

All trailing arms and also the wheel carrier are manufactured in aluminum forging technology. This design reduces the unsprung masses of the wheel-controlling components in comparison to the E9x M3 by about 3 kg (6.6 lbs).

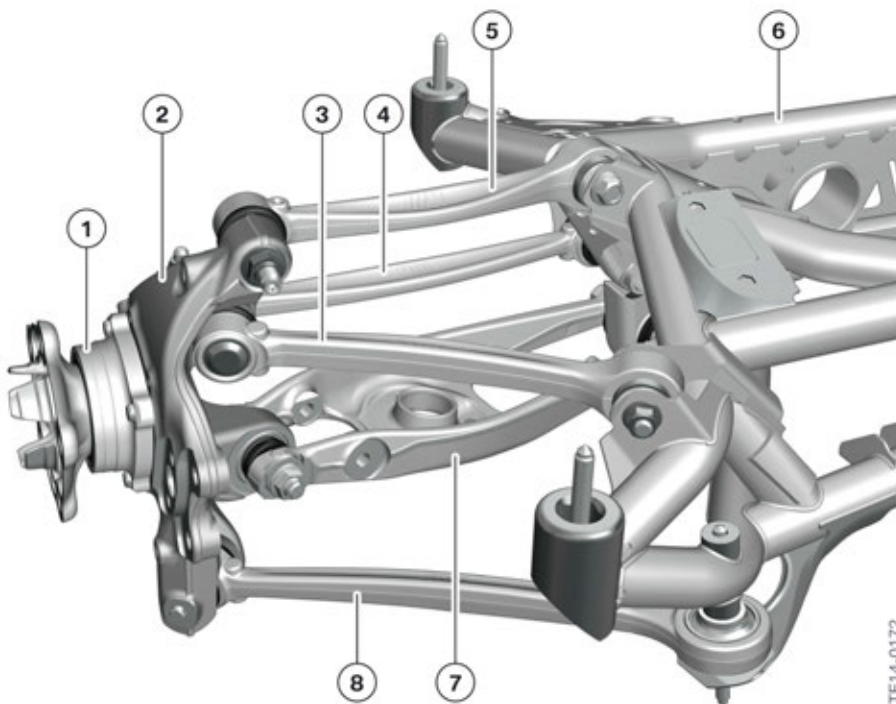

F80/F82 five-link arrangement with wheel carrier

Index	Explanation
1	M wheel bearing unit with drive flange
2	M hub carrier
3	M control arm
4	M track control arm
5	M wishbone
6	M rear axle support
7	M camber control arm
8	M trailing arm

The rear axle support itself is made from steel tubing which is similar to a steel tube grid frame.

F80/F82 Complete Vehicle

5. Chassis and Suspension

This design is characterized by maximum rigidity and minimal weight. The M rear axle support is fixed to the body without a bearing. This fixed connection (bolted) directly to the body ensures an optimized wheel guiding and thus enhanced directional stability. In addition, through the use of diagonal struts a direct transmission of the longitudinal forces applied during braking to the body structure was achieved.

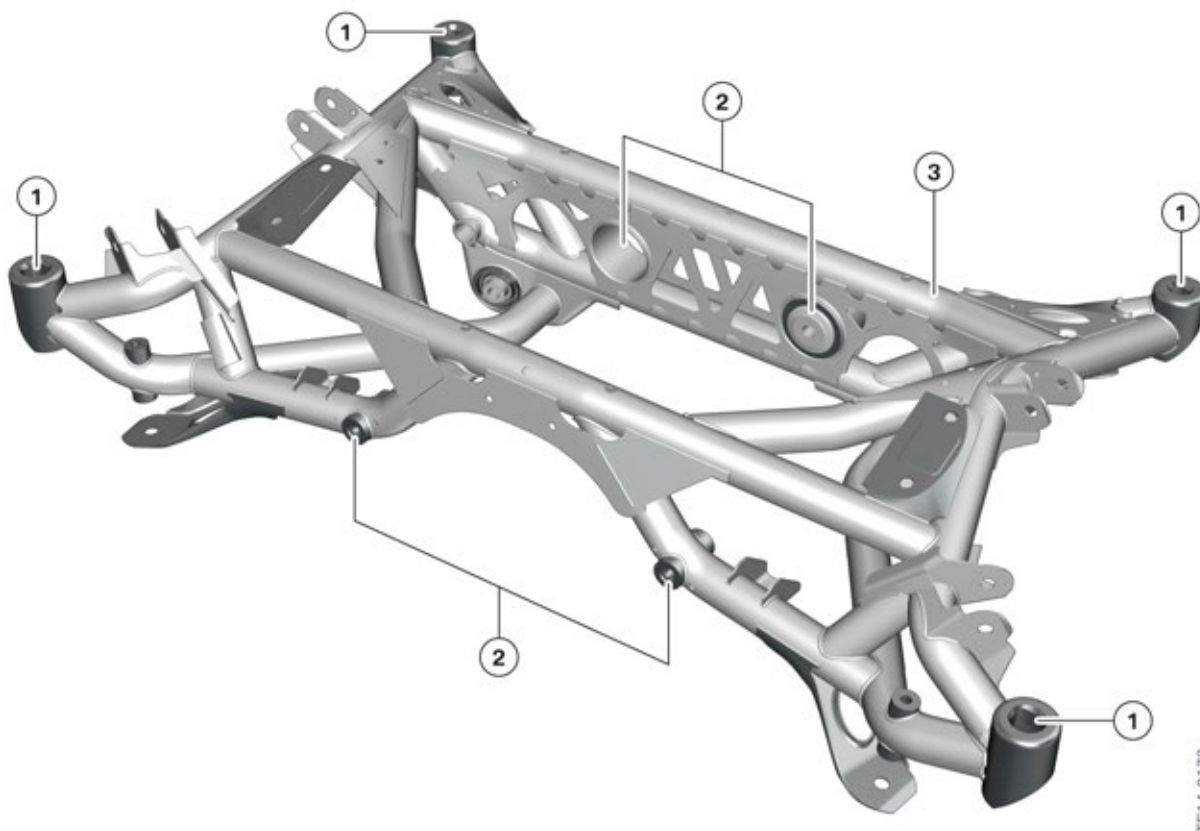

F80/F82 rear axle support

Index	Explanation
1	Attachment point, rear axle at body (fixed (bolted) connection without rubber mount)
2	Attachment point for rear axle differential (GHAG)
3	M rear axle support

Further weight savings compared to the F3x M3 was achieved with the design of the spring strut in aluminum, as well as the tubular design of the anti-roll bar like in the E9x M3.

The design of the rear axle was done in close cooperation with the tires which were also specially developed for the F80/F82.

F80/F82 Complete Vehicle

5. Chassis and Suspension

5.3. Brakes and wheels/tires

5.3.1. Brakes

M Compound brake

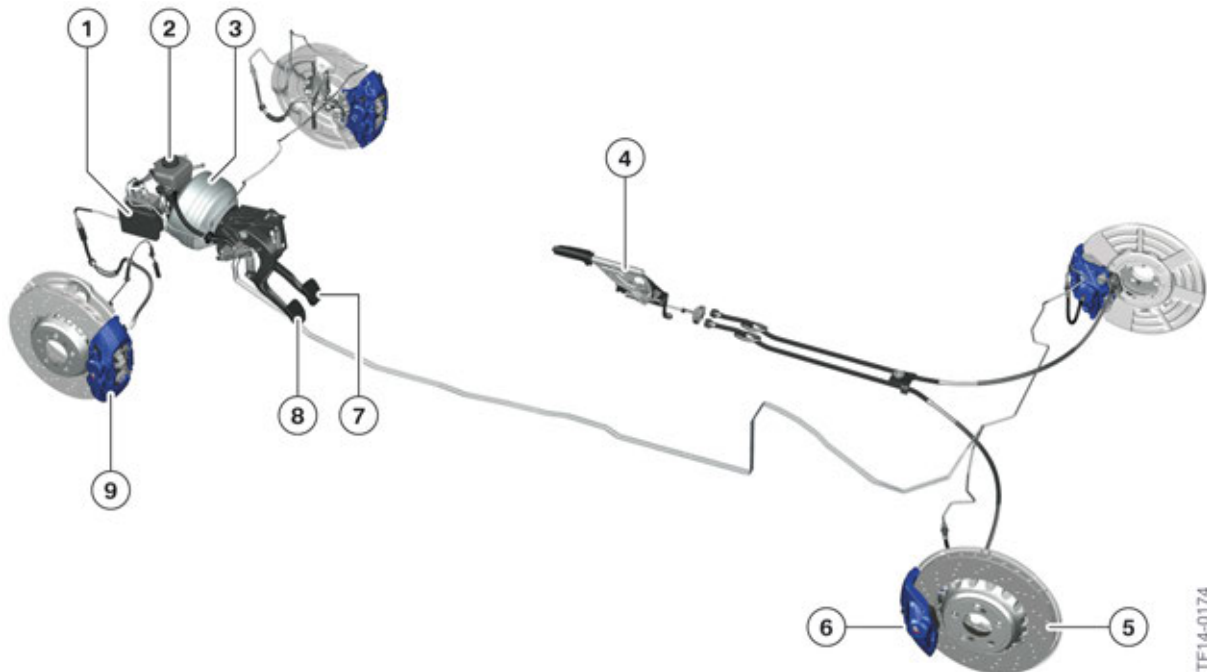

F80/F82 brake system

Index	Explanation
1	Dynamic Stability Control (DSC)
2	Brake fluid expansion tank
3	Brake servo (left-hand drive vehicle)
4	Parking brake lever
5	Rear brake disc
6	Rear double-piston fixed caliper
7	Brake pedal
8	Clutch pedal
9	Front four-piston fixed caliper

F80/F82 Complete Vehicle

5. Chassis and Suspension

Designation	Unit	E9x M3	F10 M5	F80/F82-M3/ M4 Coupe
Front brake		1 piston, floating caliper	6 pistons, fixed caliper	4 pistons, fixed caliper
Brake disc, front	[mm]	360 x 30	400 x 36	380 x 30
Rear brakes		1 piston, floating caliper	1 piston, floating caliper	2 pistons, fixed caliper
Brake disc, rear	[mm]	350 x 24	396 x 24	370 x 24
Parking brake		mechanical	electro- mechanical	mechanical

The front brakes are specific to the F80/F82. Large perforated M compound brake discs combined with a four-piston fixed calipers are used. The diameter of the brake disc is 20 mm larger than that of the E9x M3. All brake calipers will be blue with a color M logo irrespective of the external vehicle color chosen.



F80/F82 front brake

The rear brakes are specific to F80/F82. The diameter of the rear perforated M compound brake discs is 20 mm larger than that of the E9x M3. The rear brake calipers are double-piston fixed type.

F80/F82 Complete Vehicle

5. Chassis and Suspension

M Carbon ceramic brake

The M Carbon ceramic brakes are available as optional equipment from the series launch of the new F80/F82. In addition to the F10 M5, the F12 M6, F13 M6 and the F06 M6.

The M Carbon ceramic brake system is also called C/SiC brake system.

Depending on the situation, this offers a further increase in active safety compared to the M Compound brakes. In a direct comparison it also offers the following:

- Even more direct/spontaneous use of brake force
- Maximum heat resistance even with continuous sporty operation
- Higher fading stability
- Significantly reduced wear
- 7 kg (15.4 lbs) weight reduction of rotating wheel masses
- Increased suitability for winter driving conditions thanks to corrosion resistance.

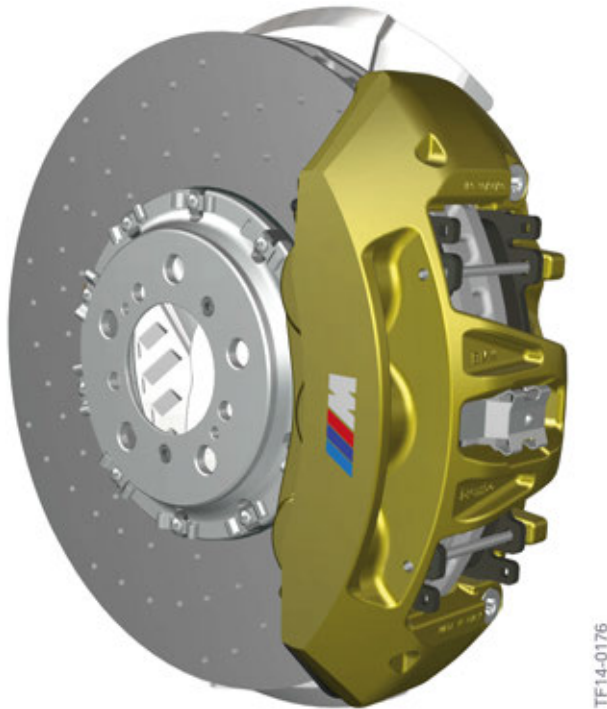

F80/F82 M Carbon ceramic brake, front axle

As a visible distinguishing feature to the M Carbon ceramic brake system uses gold painted brake calipers with a color M logo.

The F80/F82 Carbon ceramic brake system can only be used with the 19" M wheel rim due to the larger brake discs at the front.

The brake discs are manufactured by Brembo SGL Carbon Ceramic Brakes GmbH.

F80/F82 Complete Vehicle

5. Chassis and Suspension

Designation	Unit	F10 M5	F80/F82-M3/ M4 Coupe
Front brake		6 pistons, fixed caliper	6 pistons, fixed caliper
Brake disc, front	[mm]	410 x 38	400 x 38
Rear brakes		1 piston, floating caliper	4 pistons, fixed caliper
Brake disc	[mm]	396 x 26	380 x 28
Parking brake		electro- mechanical	mechanical

Further information on the M Carbon ceramic brake can be found in the " ST1216 M Carbon Ceramic Brakes" training material available in TIS and ICP.



For necessary service work the current information and specifications in the documents in the Integrated Service Technical Application (ISTA) must be observed in each case.

Dynamic Stability Control (DSC)

The MK 100 from Continental is used as a Dynamic Stability Control (DSC) system. The characteristic maps of the DSC are M-specific and adapted to the respective brake system M Compound or M Carbon ceramic brake.

Modification to brake pad wear monitoring

Similar to the E82 M Coupe and the F10 M5, the F80/F82 only has one brake pad wear sensor on the left at the front axle. The second is at the rear axle on the right.

F80/F82 Complete Vehicle

5. Chassis and Suspension

5.3.2. Wheels/tires

Summer equipment



F80/F82 summer wheels

Index	Explanation
A	18" 513M standard wheel
B	19" 437M wheel, optional equipment in two color variants

The following wheel/tire combinations are offered:

Standard equipment

Designation	E9x M3	F10 M5	F80/F82–M3/ M4 Coupe
LM EH2+ wheel rim, standard wheel, front (forged)	8.5 x 18 IS 29	9J x 19 IS 32 mm	9J x 18 IS 29 Styling 513M
LM EH2+ wheel rim, standard wheel, rear (forge)	9.5 x 18 IS 23	10J x 19 IS 34 mm	10J x 18 IS 40 Styling 513M
Standard tires, front (Michelin Pilot Super Sport)	245/40 ZR 18	265/40 ZR 19	255/40 ZR 18
Standard tires, rear (Michelin Pilot Super Sport)	265/40 ZR 18	295/35 ZR 19	275/40 ZR 18

Optional equipment

Designation	F80/F82–M3/M4 Coupe
LM EH2 wheel rim, front (forged) styling 437M	9J x 19 IS 29
LM EH2 wheel rim, rear (forged) styling 437M	10J x 19 IS 40
Tires, front (Michelin Pilot Super Sport)	255/35 ZR 19
Tires, rear (Michelin Pilot Super Sport)	275/35 ZR 19

The components of the above-listed wheel/tire combinations have been developed especially for the F80/F82. This can be recognized by the star on the outer side of the tire, among other things.

F80/F82 Complete Vehicle

5. Chassis and Suspension

Other combinations may have a negative effect on the performance and the drivability of the F80/F82 and lead to forfeiture of the operating licence with forfeiture of the insurance coverage.

5.4. Dynamic handling control systems

The M-specific coordination of the driving dynamics (longitudinal, transverse and vertical) was done on the Nürburgring Nordschleife. The main criteria were handling and the lap times.

5.4.1. Vertical Dynamics Management

For vehicles with a M sports suspension (SA 2VF) the Electronic Damper Control (EDC) is installed. Here four continuously adjustable shock absorbers with coupled rebound/compression stage adjustment produce damping forces according to requirements.

Through the use of forged aluminum dampers, the weight of the M sports suspension in the M3/M4 Coupe was able to be reduced by about 5.5 kg / 12.1 lbs when compared to the adaptive chassis and suspension in the F3x M3. Therefore the M sports suspension also contributes to the consistent lightweight construction concept of the new M3/M4 Coupe.

The EDC function integrated in the M Vertical Dynamics Management control unit (M VDM) controls the adjustable dampers.

The vehicle's drivability can be influenced with regards to driving dynamics via the M sports suspension (EDC) button in the driving dynamics button panel at the center console. The program selection can also be pre-configured in the MDrive menu and selected via the corresponding M button on the steering wheel.

F80/F82 Complete Vehicle

5. Chassis and Suspension

System overview

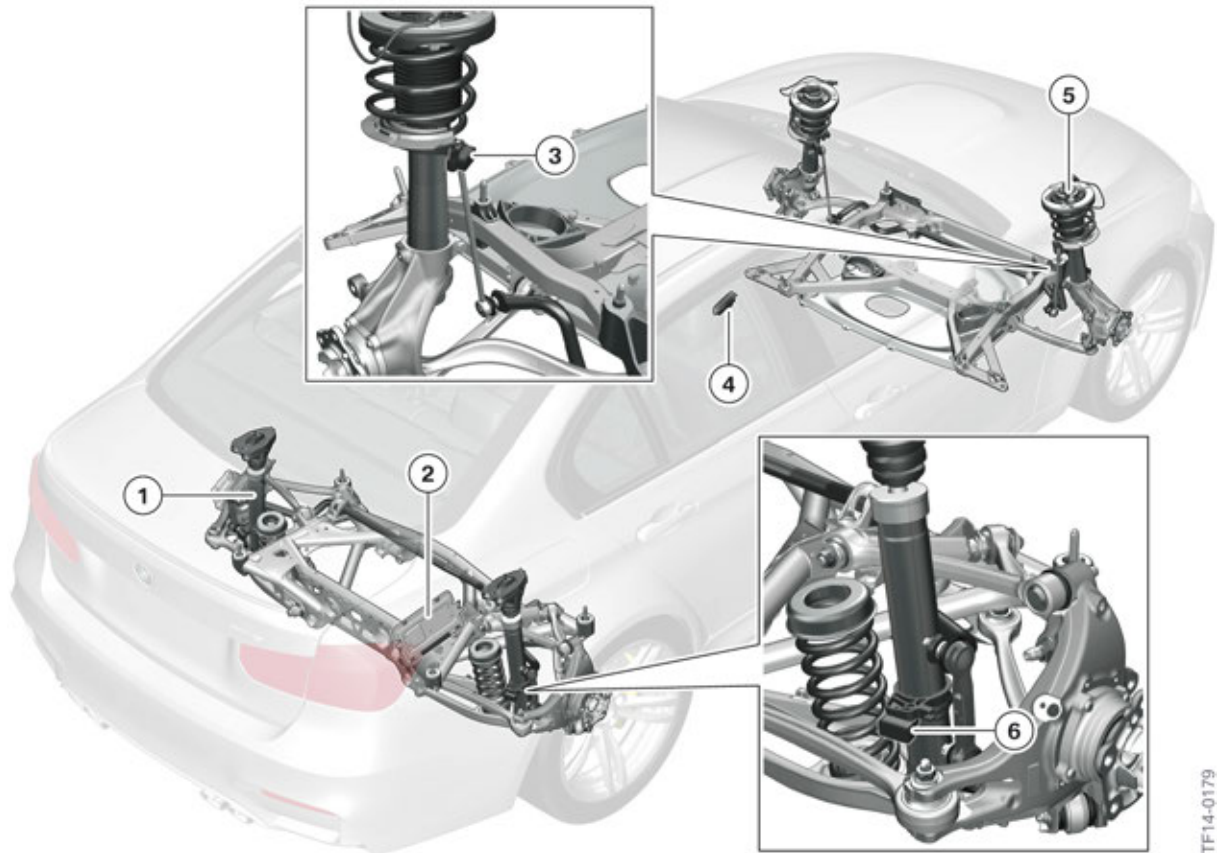

TF14-0179

F80/F82 system overview of EDC

Index	Explanation
1	Electronic adjustable damper, rear
2	VDM control unit
3	Wheel acceleration sensor, front
4	EDC button
5	Electronic adjustable damper, front
6	Wheel acceleration sensor, rear

F80/F82 Complete Vehicle

5. Chassis and Suspension

System wiring diagram

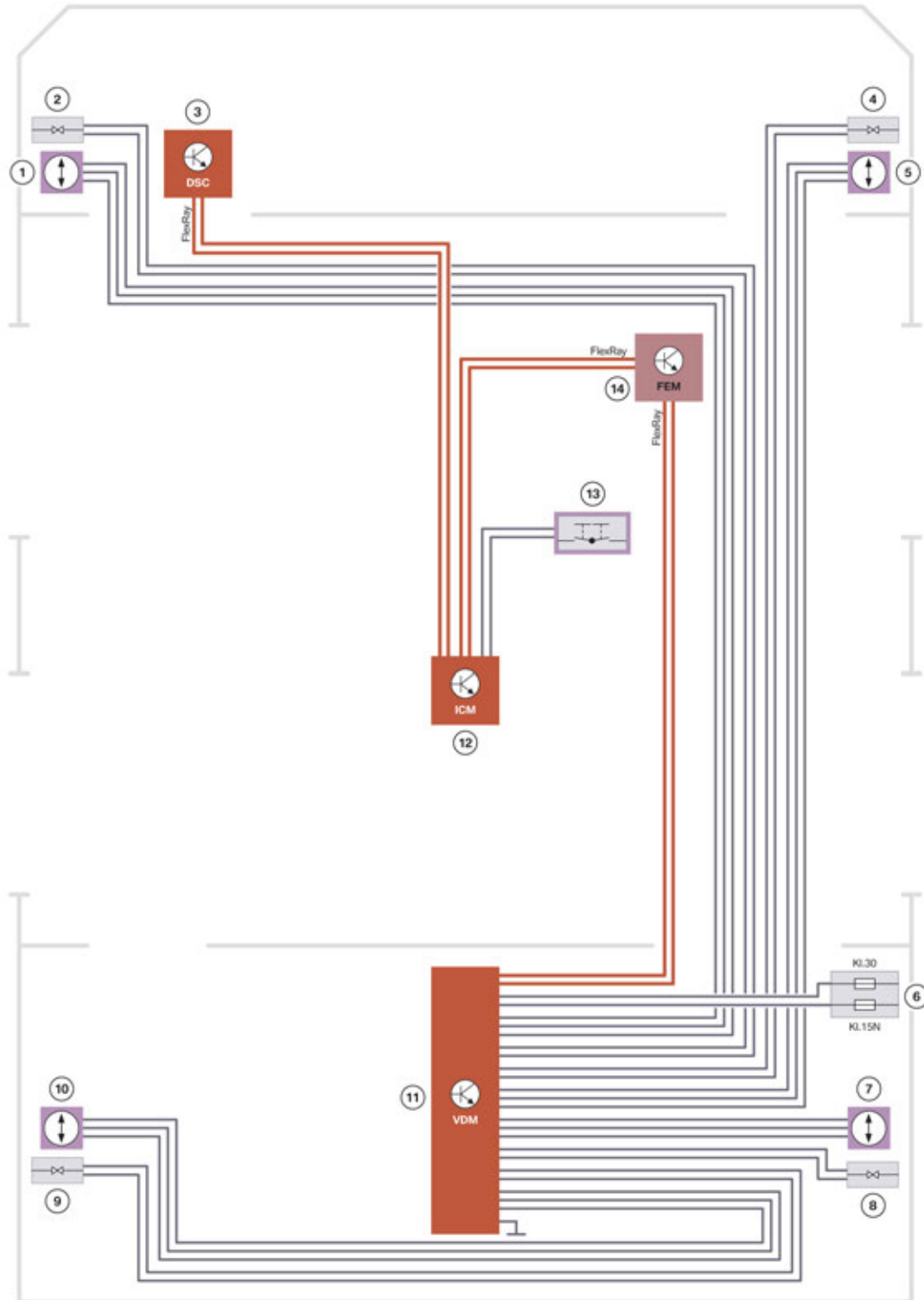

TF14-0454

F80/F82 system wiring diagram of EDC

F80/F82 Complete Vehicle

5. Chassis and Suspension

Index	Explanation
1	Vertical wheel acceleration sensor, front left
2	Electromagnetic adjusting valve, front left
3	Dynamic Stability Control (DSC)
4	Electromagnetic adjusting valve, front right
5	Vertical wheel acceleration sensor, front right
6	Power distribution box, luggage compartment
7	Vertical wheel acceleration sensor, rear right
8	Electromagnetic adjusting valve, rear right
9	Electromagnetic adjusting valve, rear left
10	Vertical wheel acceleration sensor, rear left
11	Vertical Dynamics Management (VDM)
12	Integrated Chassis Management (ICM)
13	EDC button
14	Front Electronic Module (FEM)
Terminal 30	Terminal 30
Terminal 15N	Ignition (after-run)

System function

The Electronic Damper Control (EDC) is a variable, electronically controlled shock absorber adjustment system that controls the vertical dynamics of the vehicle. The front axle damper and rear axle damper can be controlled independent of each other. The EDC adapts the damping forces of the shock absorber more or less instantly to the changing road or driving conditions.

The Electronic Damper Control (EDC) is installed with the optional equipment SA 2VF "M sports suspension".

The EDC consists of:

- four continuously adjustable shock absorbers with coupled rebound/compression stage adjustment
- the VDM control unit
- two wheel acceleration sensors on the front axle to determine the wheel movement
- two wheel acceleration sensors on the rear axle to determine the wheel movement
- a sensor cluster integrated into the ICM control unit which determines the body movements (pitch, vertical, roll).

F80/F82 Complete Vehicle

5. Chassis and Suspension

The sensors in the vehicle permanently measure:

- the body and wheel acceleration
- the current lateral and longitudinal acceleration
- the vehicle speed
- the steering wheel position

Based on this measured data, the VDM control unit calculates the control commands to be sent to the electromagnetic valves in the shock absorbers for each individual wheel according to the road profile and driving situation. This means that the damping forces will always be applied according to the requirements.

This improves ride comfort and also increases driving dynamics.

This improves the vehicle's:

- Suitability for long-distance journeys
- Enhanced body stability and agility
- Improves driving safety by minimizing wheel load fluctuations and reducing the stopping distance.

M sports suspension (EDC) button option

The button obtains its ground from the ICM and sends back a ground signal upon actuation to the ICM. The ICM forwards this information on the FlexRay data bus to the M VDM.

In the F80/F82 Electronic Damper Control there are options "Comfort", "Sport" and "Sport+". All three programs have dynamic control in the F80/F82.

Note:

In the first E92/E90 M3 models the EDC had the three options, "Comfort", "Normal" and "Sport", whereby with the "Sport" option there is no dynamic control, but the dampers are set very hard. This is primarily suited for a cone slalom on an even surface. However, the fastest possible times on normal roads cannot be achieved with the "Sport" option. The E93 M3 was dynamically controlled from standard production in "Sport" mode, as well as in all subsequent models in the F10 M5, F12/F13 M6 and the F06 M6 in "Sport+" mode.

Program description

- "Comfort" emphasizes the comfortable design in the F80/F82 in order to satisfy the comfort requirements of a M3/M4 Coupe customer. The damper hardness is set to comfortable.
- "Sport" supports a dynamic and sporty driving style with increased damper hardness.
- "Sport+" in the F80/F82 means that dynamic control now also takes place here, whereby the damper hardness is increased further in comparison to "Normal". It may therefore also be the best selection for the fastest times on different route profiles on very even surfaces, unlike a route profile similar to a "cone-lined slalom".

F80/F82 Complete Vehicle

5. Chassis and Suspension

5.4.2. Transverse dynamics management

Integrated Chassis Management

The ICM is the transverse dynamics system network. This control unit coordinates the interaction between the M Servotronic (EPS), DSC, M sports suspension, engine control, M DCT and the regulated rear axle differential lock (GHAS).

5.4.3. Longitudinal dynamics management

The LDM is performed by the DSC. The DSC MK 100 from Continental is used in the F80/F82.

M dynamic mode and DSC OFF mode

In M dynamic mode (MDM) the control threshold of the brake interventions is expanded/raised and the engine power reduction by the ASC is applied significantly later. This enables driver-oriented dynamic and sporty drivability.

The "DSC" driving dynamics button or the configuration in the MDrive menu is used to switch between "DSC ON", "MDM" and "DSC OFF". The button obtains its mass from the ICM and sends back a mass signal upon actuation to the ICM. The ICM forwards this information on the FlexRay data bus to the DSC.

F80/F82 Complete Vehicle

6. General Vehicle Electronics

6.1. Voltage supply

6.1.1. Overview

For the first time the voltage supply in a BMW M vehicle, an energy storage device other than the lead-acid battery is used. In the new F80/F82 a li-ion starter battery is installed for the series launch, which supplies the vehicle electrical system with voltage. Depending on the structure and/or the material used for the electrodes, li-ion batteries are subdivided. In this case it is lithium-iron phosphate. The outer appearance of the li-ion starter battery does not differ from a normal starter battery, all components of the li-ion starter battery are located in the same housing.

All other functions and components of the voltage supply are based on the F3x. Further information can be found in the Training Reference Manual ST1311 F30 Complete Vehicle.



F80/F82 li-ion starter battery

6.1.2. Advantages

The following advantages come with the use of a li-ion starter battery, which were decisive for the use of this technology in a high-performance vehicle like the F80/F82:

- **Weight saving:**
Also here in the area of the starter battery the concept of the intelligent lightweight construction in the new F80/F82 was pursued. With the use of the li-ion starter battery the weight of the starter battery was able to be reduced by about 12.5 kg / 27.5 lbs . The li-ion starter battery only weighs 14 kg / 30.8 lbs in comparison to a conventional AGM 90 Ah battery with about 26.5 kg / 58.3 lbs.
- **CO₂ saving:**
A CO₂ saving can be achieved with a higher automatic engine start/stop function (MSA) availability. With a conventional lead-acid battery the regeneration capacity is not as high as with a li-ion battery as a result of the intelligent generator control. The li-ion starter battery can absorb considerably higher currents in a shorter time for charging in comparison to the lead-acid battery. This makes it ideal for use in vehicles with intelligent generator control (IGR).

F80/F82 Complete Vehicle

6. General Vehicle Electronics

- Life cycle:**
 The number of available full cycles for li-ion battery is 14 times higher than for a conventional lead-acid battery. The li-ion battery is therefore the optimal alternative for use of the automatic engine start/stop function (MSA) in conjunction with the intelligent generator control (IGR). The battery life is also about twice as high as the traditional lead-acid battery.
- Maintenance-free:**
 Maintenance-free, as no maintenance is required after topping up with distilled water (not with AGM batteries).
- Ideal voltage level:**
 With the use of lithium iron phosphate cells (LiFePO₄), which have a nominal voltage of 3.3 V per cell, a nominal voltage of the li-ion starter battery of 13.2 V could be achieved.
- Very high intrinsic safety:**
 Lithium iron phosphate cells (LiFePO₄) generally have an even lower hazard potential than other lithium-based batteries.

6.1.3. Comparison of li-ion starter battery/lead starter battery

Designation	Unit	Lead-acid battery/ AGM battery	Li-ion battery
Nominal voltage	[V]	12	13,2
Cell voltage	[V]	2	3,3
Rated capacity	[Ah]	90	69
Number of cells	[Quantity]	6	4
Weight	[kg / lbs]	26,5 / 58.3	14 / 30.8
Possible charging cycles	[Quantity]	about 350	about 5.000
Charging end voltage Ideal/Maximum	[V]	14,2/16	14.0/temperature-dependent
Discharging		No total discharge protection/ battery damage	Total discharge protection at 8 V
Battery sensor system		Intelligent battery sensor (IBS)	Battery supervision circuits (BUE) in battery
Housing	[DIN]	LN5	LN5
Ventilation		Standard DIN housing with ventilation line	Standard DIN housing with extended ventilation line (18.5 mm)
Application range		Every vehicle	Only in the F80/F82

F80/F82 Complete Vehicle

6. General Vehicle Electronics

6.1.4. Structure of the li-ion starter battery

External structure

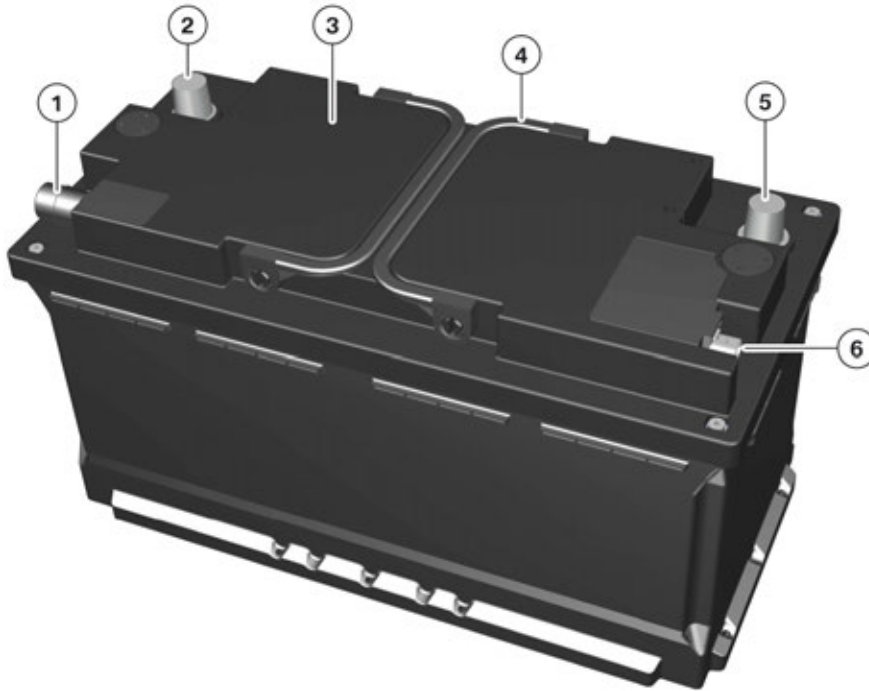

TE14-0181

F80/F82 li-ion battery, external view

Index	Explanation
1	Ventilation connection
2	Positive terminal
3	Battery housing
4	Holder
5	Negative terminal
6	LIN connection

F80/F82 Complete Vehicle

6. General Vehicle Electronics

Inner structure

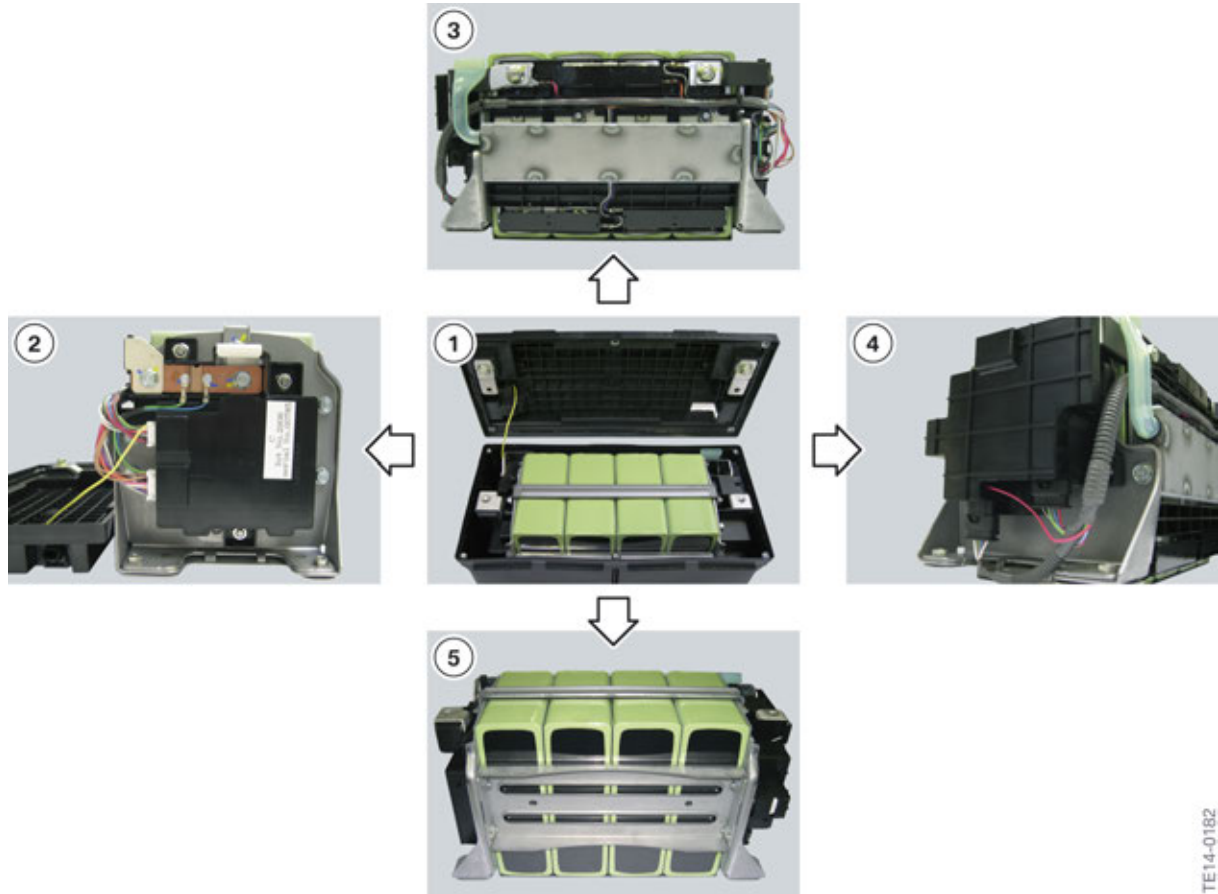

F80/F82 li-ion battery

TE14-0182

Index	Explanation
1	Inner structure
2	Battery supervision circuits (BUE) with precision resistor
3	Metal ventilation chute
4	Electronic disconnect switch (2 relays)
5	Four li-ion battery cells

F80/F82 Complete Vehicle

6. General Vehicle Electronics

6.1.5. Function

In addition to the four cells, there are also electronics and a battery isolating switch (2 relays) in the housing of the battery.

Integrated electronics "Battery supervision circuits"

The integrated electronics, the so-called battery supervision circuits (BUE), are responsible for the:

- Communication via LIN data bus with FEM/DME
- Diagnostics
- Wake-up function via FEM via LIN data bus
- Current monitoring of the individual cells and battery
- Closed-circuit current monitoring
- Voltage monitoring of the individual cells and battery
- Cell voltage adaptation with counter function via passive system (resistance)
- Startability monitoring
- Temperature monitoring with resulting temperature model
- Internal resistance monitoring
- State of charge monitoring
- Battery condition monitoring
- Battery capacity monitoring
- Data memory for battery information
- Activation of the battery isolating switch in the event of a fault.

The battery supervision circuits use the plug connection of the IBS. This is why there is no IBS installed in the F80/F82. All functions of the IBS are assumed in the F80/F82 by the battery supervision circuits.

The battery supervision circuits cannot be replaced separately and are only offered together with the battery.

Battery isolating switch

The battery isolating switch (relay) is present twice, whereby it is a redundant system. This means in the event of failure of one switch (relay) the second battery isolating switch (relay) assumes the task.

The battery isolating switch is activated by the battery supervision circuits and is responsible for protecting the li-ion cells from external and internal influences in the event of a fault.

The following parameters may have effects on the position of the battery isolating switch:

- Voltage
- Current
- Temperature

F80/F82 Complete Vehicle



6. General Vehicle Electronics

The following table illustrates the possible positions of the electronic disconnect switch:

Position	Voltage	Current	Temperature
Battery isolating switch open	<ul style="list-style-type: none"> Over voltage Under voltage 	<ul style="list-style-type: none"> Charge current too high Short circuit current. 	<ul style="list-style-type: none"> Temperature over 80 °C (176 °F).
Battery isolating switch closed	normal	normal	normal

The battery isolating switch cannot be replaced separately and is only offered together with the battery.

6.1.6. Actions in the event of a fault

Cause	Impact and effects	Measure
Overloading	Battery isolating switch opens.	Remove voltage source. Battery isolating switch closes again after voltage drop.
Total discharge below 8 V for over 60 seconds	Battery isolating switch opens.	Connect charger/Jump-start. Battery isolating switch closes again after voltage detection.
Gas emission (cell fault, misuse)	Smoke formation  <hr/> Caution: Risk of burning! <hr/> Caution: Hazardous gases.	Remove people from danger area. Provide fresh air. Replace battery. Replace ventilation hose.
External impacts and effects	Damage to housing, poss. mechanical cell damage or damage to internal components.	Replace battery and dispose of battery properly.
Gas emissions with ignition source over 500 °C	Gas ignites with corresponding concentration and ignition source.  <hr/> Caution: Risk of burning! <hr/> Caution: Hazardous gases.	Remove people from danger area. Provide fresh air. Inform fire brigade. Extinguish using a standard fire extinguisher. Replace battery if necessary. Replace ventilation hose if necessary.

F80/F82 Complete Vehicle

6. General Vehicle Electronics

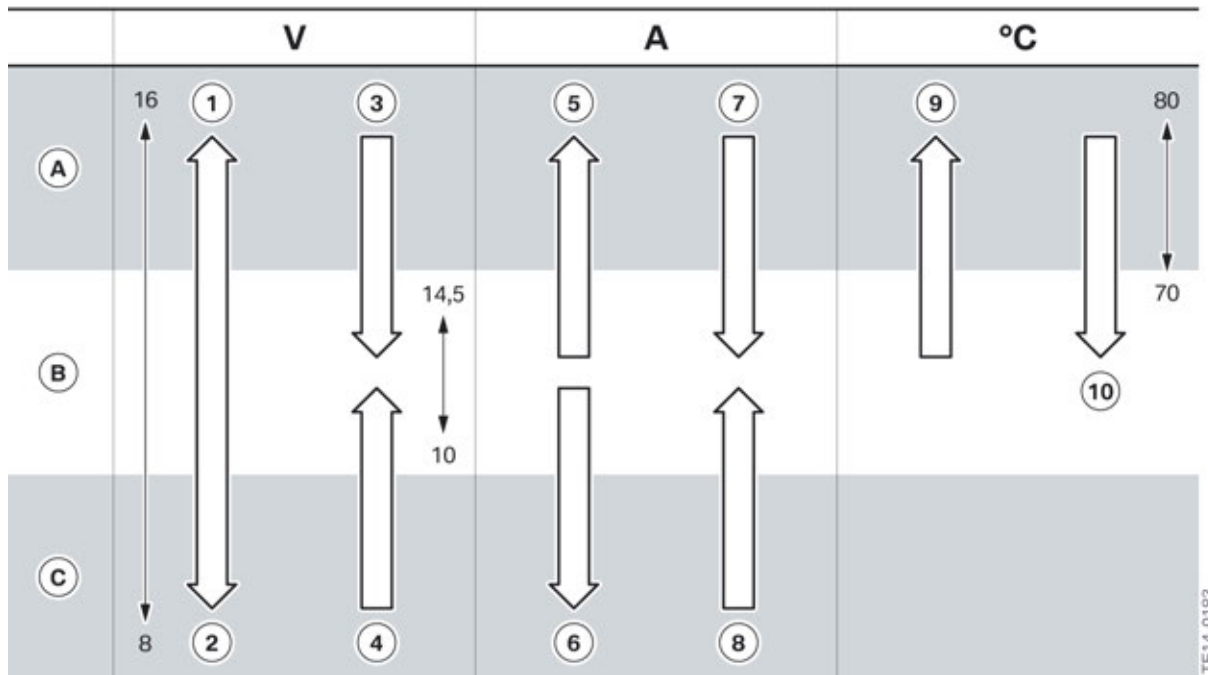

Possible battery isolating switch positions

Index	Explanation
V	Voltage in volts
A	Current in A
°C	Temperature in degree Celsius
A	Battery isolating switch open
B	Battery isolating switch closed
C	Battery isolating switch open
1	Overvoltage-overload protection (cell voltage > 4 V/battery voltage > 16 V)
2	Undervoltage-total discharge protection (cell voltage < 2 V/battery voltage < 8 V after 30 seconds)
3	Overvoltage no longer present (battery voltage < 14.5 V for 2 seconds)
4	Charging voltage applied (battery voltage > 10 V for 2 seconds)
5	Charge current from charger too high
6	Short circuit current
7	Terminal voltage < Module voltage (for > 2 seconds)
8	Charging voltage applied
9	Temperature > 80° Celsius / 176 ° F.
10	Temperature < 70° Celsius / 158 ° F.

F80/F82 Complete Vehicle

6. General Vehicle Electronics



If the voltage falls below 8 V and the battery isolating switch opens, this becomes noticeable by a vehicle electrical system without voltage. Electrical functions are therefore no longer available. In this case the battery should not be replaced.. It is possible to recharge the battery. As soon as the battery supervision circuits detect a voltage over 10 V for longer than 2 seconds, the battery supervision circuits close the battery isolating switch. The vehicle electrical system is supplied with voltage. All electrical functions are now available. The battery is then charged.

The battery only has to be replaced if the battery isolating switch no longer closes or the energy diagnosis specifies a replacement.

Refer to SIB 04 06 14 for more information.

F80/F82 Complete Vehicle

6. General Vehicle Electronics

6.1.7. System wiring diagram

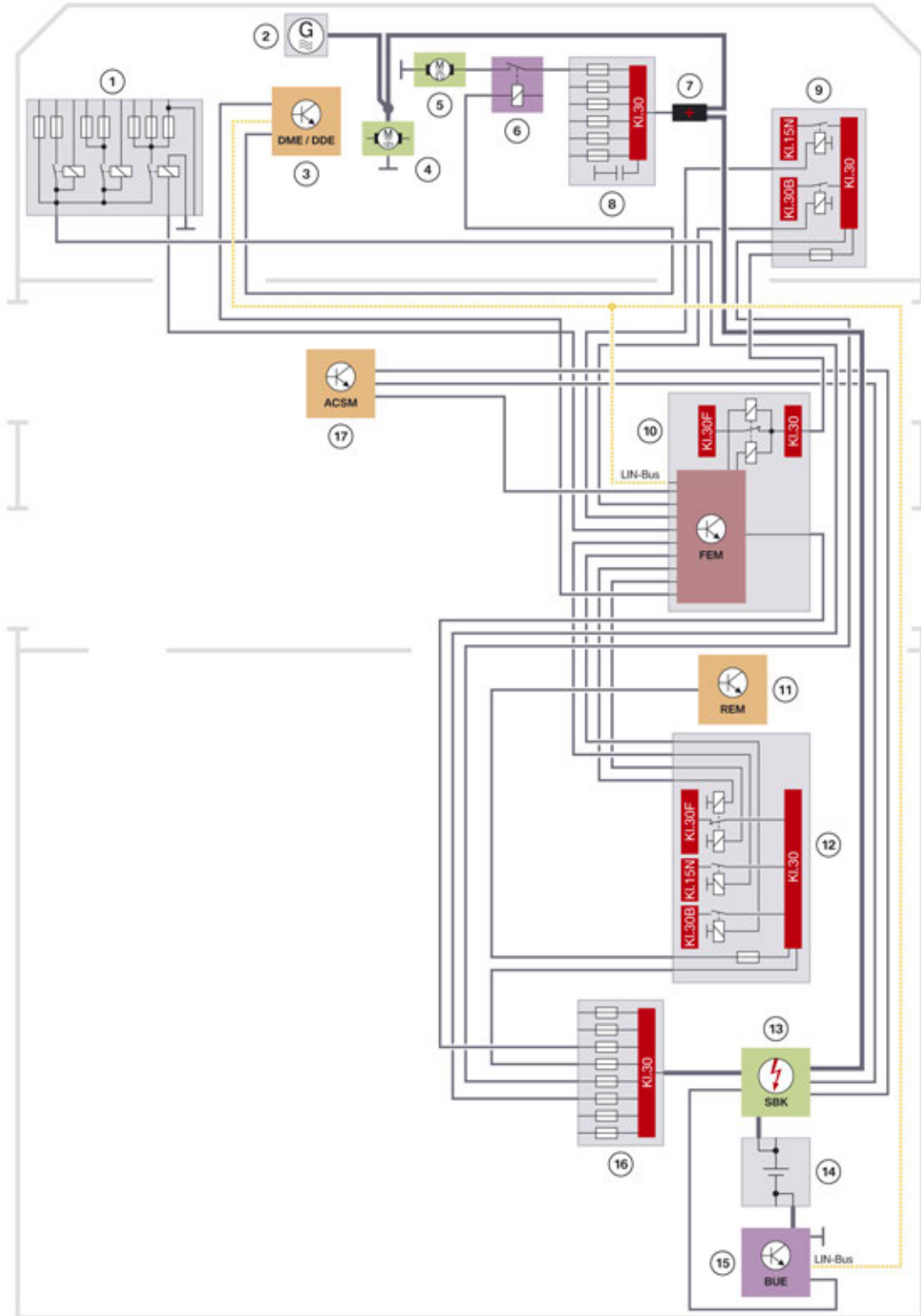

F80/F82 Voltage supply

TE14-0184

F80/F82 Complete Vehicle

6. General Vehicle Electronics

Index	Explanation
1	Power Distribution Module (PDM)
2	Alternator
3	Digital Motor Electronics DME
4	Starter motor
5	Electric fan
6	Relay for electric fan
7	B+ jump start terminal point
8	Power distribution box, front
9	Power distribution box, engine compartment
10	Front Electronic Module (FEM)
11	Rear Electronic Module (REM)
12	Power distribution box, luggage compartment
13	Safety battery terminal (SBK)
14	Li-ion starter battery
15	Battery supervision circuits (BUE)
16	Battery power distribution box
17	Crash Safety Module (ACSM)
Terminal 30	Terminal 30
Terminal 30B	Terminal 30 basic operation
Terminal 15N	Ignition (after-run)
Terminal 30F	Terminal 30, fault-dependent

6.1.8. Li-ion starter battery in Service

Charging

For charging the li-ion starter battery during Service chargers recommended by BMW with corresponding function software for li-ion starter batteries can be used. Software updates are available for the following battery chargers approved by BMW:

- Deutronic 800
- Deutronic 1200
- Deutronic 1600
- ELTEK 750, 900 & 1500

Please observe the operating instructions of the charger manufacturer.

F80/F82 Complete Vehicle

6. General Vehicle Electronics



The maximum charging voltage of the li-ion batteries cannot be exceeded. Therefore, use chargers recommended by BMW with the corresponding function software for li-ion starter batteries.

The charge current at low temperatures must be restricted. The li-ion starter battery is damaged by excessive charge currents at low temperatures. Therefore, use chargers recommended by BMW with the corresponding function software for li-ion starter batteries.

Replacement

In each case the current repair instructions in the Integrated Service Technical Application (ISTA) must be observed.

Disposal

Information on the disposal of the li-ion starter batteries is available from your respective Environmental Officer.

General handling of li-ion starter battery

Instructions on the handling of li-ion starter battery is available in the safety datasheet.



For necessary service work the current information and specifications in the documents in the Integrated Service Technical Application (ISTA) must be observed in each case.

F80/F82 Complete Vehicle

6. General Vehicle Electronics

6.2. Bus overview

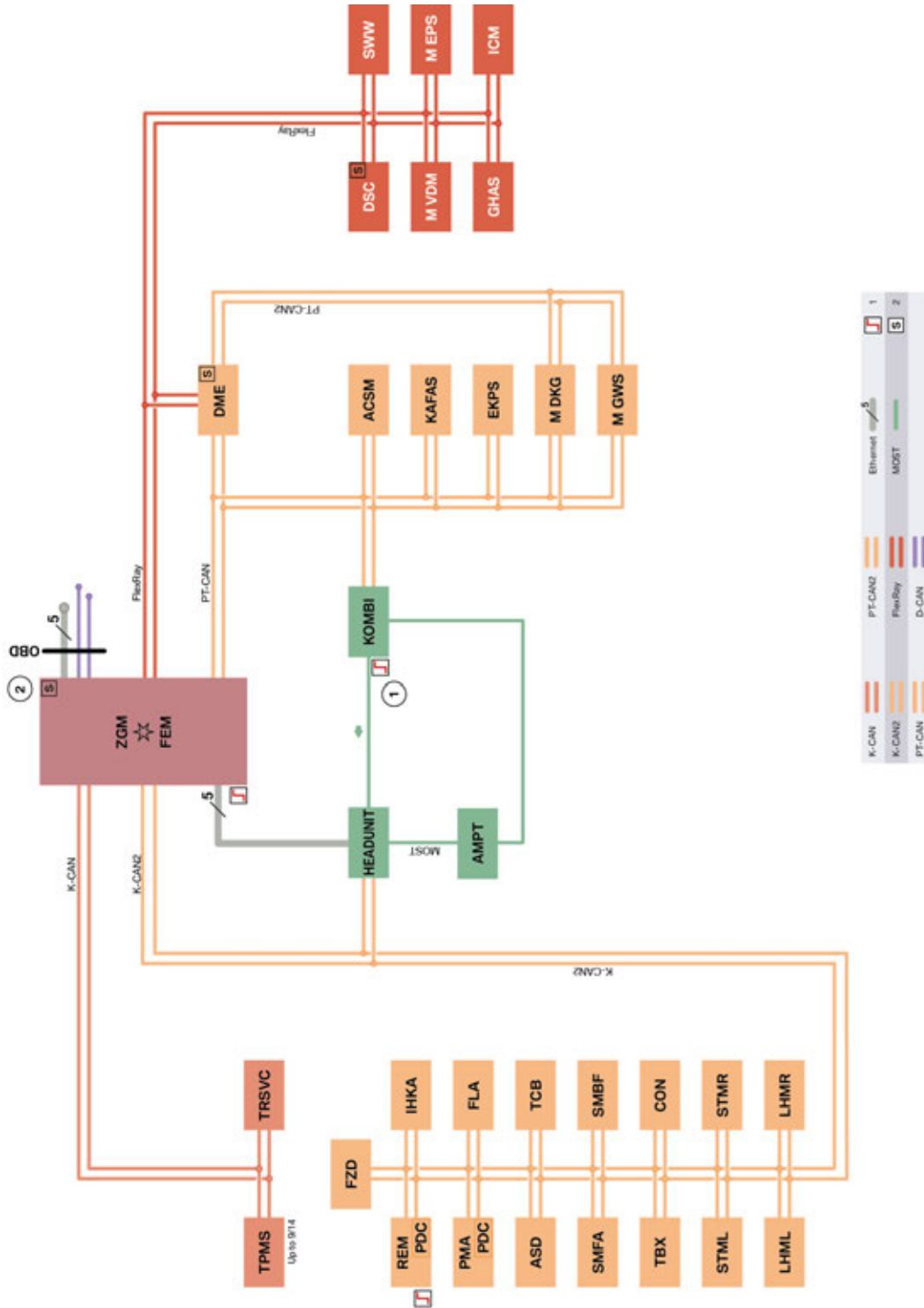

F80/F82 bus overview

F80/F82 Complete Vehicle

6. General Vehicle Electronics

Index	Explanation
1	Control units with wake-up authorization
2	Start-up node control units for starting and synchronizing the FlexRay bus system
ACSM	Advanced Crash Safety Module (ACSM)
ASD	Active Sound Design
AMPT	Top HiFi amplifier
COMBOX	Combox (Combox emergency call, Combox Multimedia)
CON	Controller
D-CAN	Diagnosis-on-Controller Area Network
DME	Digital Motor Electronics
DSC	Dynamic Stability Control
EKPS	Electronic fuel pump control
Ethernet	Cable-based data network technology for local data networks
FEM	Front Electronic Module
FLA	High-beam assistance
FlexRay	Fast, preset and fault-tolerant bus system for use in automotive sector
FZD	Roof function center
GHAS	Regulated differential lock
HEADUNIT	Headunit (Headunit High (HU-H) or Headunit Basic (HU-B))
ICM	Integrated Chassis Management
IHKA	Integrated automatic heating / air conditioning
K-CAN	Body controller area network
K-CAN2	Body controller area network 2
KAFAS	Camera-based driver support systems
KOMBI	Instrument cluster (MOST only with SA 6WA)
M DKG	M Double-clutch Transmission (M DCT)*
M EPS	M Servotronic (EPS) Electronic Power Steering (electromechanical power steering)
M GWS	M gear selector switch
MOST	Media Oriented System Transport
M VDM	M Vertical Dynamics Management
LHML	LED main light module on the left
LHMR	LED main light module on the right
OBD	On-board diagnosis (diagnostic socket)

F80/F82 Complete Vehicle

6. General Vehicle Electronics

Index	Explanation
PDC	Park Distance Control (with SA 5DP, Parking Maneuvering Assistant: integrated in the Parking Maneuvering Assistant control unit, otherwise integrated in the Rear Electronic Module control unit)
PMA	Parking maneuvering assistant
PT-CAN	Powertrain controller area network
PT-CAN 2	Powertrain controller area network 2
REM	Rear Electronic Module
STML	Left-hand Headlight Driver Module
STMR	Right Headlight Driver Module
SMFA	Seat module, driver
SMFB	Seat module, passenger
SWW	Lane change warning
TBX	Touchbox
TCB	Telematic Communication Box
TPMS	Tire pressure monitoring system (up to 3/2014)
TR SVC	Control unit for all-round vision cameras
ZGM	Central gateway module



* The M DKG (M Double-clutch Transmission) is referred to as M DCT in the US market due to a marketing decision.

The following deviations exist in comparison to the standard F3x:

PT-CAN

The S55B30T0 engine exclusively obtains the DME variant MEVD17.2.G. In place of the electronic transmission control (EGS) the M Double-Clutch Transmission Drivelogic (M DKG/M DCT) is used and instead of the gear selector switch (GWS) the M gear selector switch (GWS) with Drivelogic button is used.

FlexRay

The regulated rear axle differential lock (GHAS) is also new.

K-CAN

Active Sound Design (ASD) is new.

MOST

There is no difference to the current F3x vehicle electrical system.

F80/F82 Complete Vehicle

6. General Vehicle Electronics

6.3. On-board information

6.3.1. MDrive menu

The MDrive menu can be found in the Settings menu. There are two individually adjustable M Drive configurations, M Drive1 and M Drive2.

The settings performed there are called up by pressing the corresponding button of the two available M buttons on the multifunction steering wheel.



F80/F82 MDrive button

Index	Explanation
1	M1 Button
2	M2 Button

There are two M buttons on the steering wheel thus enabling two different settings to be saved and called up.

The activation of an MDrive configuration is displayed by an M1 or M2 symbol in the instrument cluster. The corresponding symbol flashes if for example ABS or DSC adjust upon activation of request. A renewed activation is only possible if the control is completed.

F80/F82 Complete Vehicle

6. General Vehicle Electronics

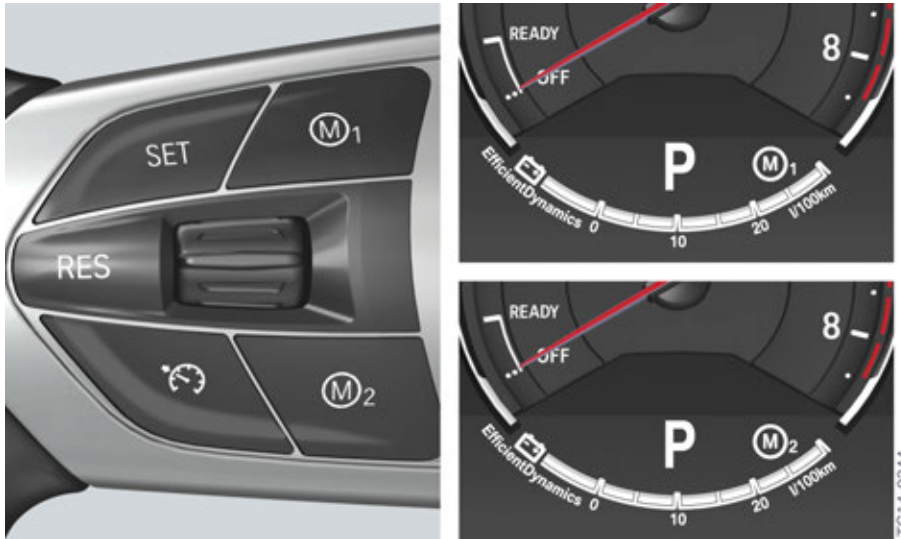

F80/F82 MDrive combination display

During the journey a requested configuration can be temporarily changed at any time until "Ignition OFF". The corresponding driving dynamics button must be operated. The M1 or M2 symbol in the instrument cluster goes out.

An efficient/comfortable configuration is set by default in the factory for the M1 button and a sporty configuration for the M2 button. This setting can be adapted in the MDrive menu to the customer's needs and also reset again to the factory setting. Each M button is individually configurable and the overall configuration is also assigned to the vehicle remote control being used.

If the DSC selection "MDM" or "DSC OFF" is chosen, a repeated, i.e. second operation, of the corresponding M button is required for activation of the configuration for approval reasons.



F80/F82 MDrive menu, DSC confirmation



New approval requirements require an additional confirmation, if the MDrive configuration includes "DSC MDM" or "DSC OFF".

F80/F82 Complete Vehicle

6. General Vehicle Electronics

The following functions and configurations can be selected and set:

Dynamic Stability Control (DSC)

- ON
- MDM
- OFF

Engine dynamics control incl. ASD (Active Sound Design)

- Sport +
- Sport
- Efficient

Electronic Damper Control

- Sport +
- Sport
- Comfort

M Servotronic (EPS)

- Sport +
- Sport
- Comfort

Head-Up Display

- M view
- Unchanged

Drivelogic

- Drivelogic program "S" switch position (bar) 1-3
- Drivelogic program "D" switch position (bar) 1-3

Configuration quick save

A modified M setting or a new M setting using the drive dynamic buttons can be assigned to one of the two M buttons on the steering wheel M1 or M2. The corresponding M button on the steering wheel must be pressed and held for two seconds. The current configuration is set and overwrites any previously saved settings. This allows quick saving without accessing the M Drive menu.

F80/F82 Complete Vehicle

6. General Vehicle Electronics



If the driver is not aware that holding down the M button overwrites the current configuration/setting, this may lead to an unjustified customer complaint.

Active configuration

The individual driving stability controls can be set by the driver (while driving) using the assigned buttons. Then one of the two M buttons on the steering wheel can be pressed and held for 2 seconds to save the current configuration.

6.3.2. M instrument cluster

The M instrument cluster is based on the instrument cluster high version from the F3x. The respective scales of the instrument cluster are market- and vehicle-specific.

The following M-specific changes exist in comparison to the F3x:

Round instruments:

- Speed and engine speed display correspond to the drive concept (200 mph in 20 mph increments and 8,000 rpm).
- Typical M red needle, lighting of the dial in white (also during the day without driving light), M inscription.



F80/F82 instrument cluster

F80/F82 Complete Vehicle

6. General Vehicle Electronics

M-specific displays:

- MDM M dynamic mode symbol in place of the DTC
- M1 = M Drive1
- M2 = M Drive2
- Display of gear
- Display of Drivelogic (bar symbol such as a button)
- Display of system status: engine dynamics, damper control and Servotronic

In the instrument cluster the current configuration of the engine dynamics, damper control and Servotronic systems is shown in the bottom part of the rev counter field. This function can be activated under Settings in the Configuration menu display.

The confirmation of the MDrive settings for DSC, engine dynamics, transmission, EDC and Servotronic is also done centrally in the instrument cluster.

For setting/adjustment work in the engine dynamics, EDC and Servotronic systems the response of the button activation is also done as a list in the instrument cluster.

6.3.3. Head-Up Display

The optional color head-up display, depending on the national-market version, can switch to the M-specific display.

The following information/parameters can be shown:

- Shift point indicator by Shift-light function
- Engine speed over rev counter range
- Transmission shift level
- Vehicle speed
- Speed limit information (optional equipment)
- Warnings same as F3x



F80/F82 Head-Up Display

The M-specific display for corresponding configuration in the MDrive menu is activated via the M button on the steering wheel or by selecting it from the Head-Up configuration menu.

F80/F82 Complete Vehicle

6. General Vehicle Electronics

6.3.4. Active Sound Design

The Active Sound Design (ASD) is described in a separate Technical Reference Manual ST1204 Active Sound Design.

6.3.5. M Lap Timer app

This free app is an add-on for ambitious driving on the race track and enables precise analysis of the personal driving style.

The smartphone with the installed BMW M Lap Timer app is connected to the vehicle via a USB cable or the appropriate snap-in adapter.

The BMW M Lap Timer app not only records acceleration, braking points, lap times and high forces. The data is prepared in the form of graphics, the journey is played back with the real values as a virtual test drive.

In addition, the journeys of different drivers can be analyzed and compared.



F80/F82 M Lap Timer app

F80/F82 Complete Vehicle

7. Brief Overview of Equipment

7.1. F80/F82 standard equipment

- M TwinPower turbo engine and M engine dynamics button
- M instrument cluster
- MDrive menu
- M dynamic mode (MDM) with symbol button
- M Servotronic (EPS)
- M bucket seats for driver and front passenger with integrated head restraints and M moulding in the shoulder region illuminates the front, center console including armrest, armrests of doors in leather
- M interior trim finishers
- M leather steering wheel with two M multifunction buttons
- M side gill, M door sill cover strip, M driver footrest
- M3/M4 Coupe Aerodynamic package: Front and rear bumpers, front fender with extensions and gills, exterior mirror, side sill, adapted wheel arches at rear and front
- M3/M4 Coupe inscription at the rear-wheel drive, front grill and in the gills
- M exhaust tailpipe, right and left, double, round, chromium-plated
- M BMW light-alloy wheels, double spoke, 513M, 18" currently with Michelin Pilot Super Sport mixed tires
- Combined allover heat/sun protection glazing
- M4 Coupe-specific trunk lid
- M3-specific rear spoiler

7.1.1. Paint colors

- Alpine White
- Mineral White metallic
- Silverstone metallic
- Mineral grey metallic
- Black sapphire metallic
- Yas Marina blue metallic
- Sakhir orange metallic
- Austin yellow metallic

F80/F82 Complete Vehicle

7. Brief Overview of Equipment

7.1.2. Leather colors

- Silverstone grey
- Sakhir Orange
- Sonoma Beige
- Black
- BMW Individual leather trims

7.1.3. Interior trims

- Aluminium Blade
- Blue Shadow
- Carbon
- Fine-line Anthracite wood trim
- BMW Individual interior trims



Bayerische Motorenwerke Aktiengesellschaft
Qualifizierung und Training
Röntgenstraße 7
85716 Unterschleißheim, Germany