

Reference Manual



S63TU ENGINE



Technical Training

The information contained in this manual is not to be resold, bartered, copied or transferred without the express written consent of BMW of North America, LLC ("BMW NA").

Technical training.
Product information.

S63TU Engine

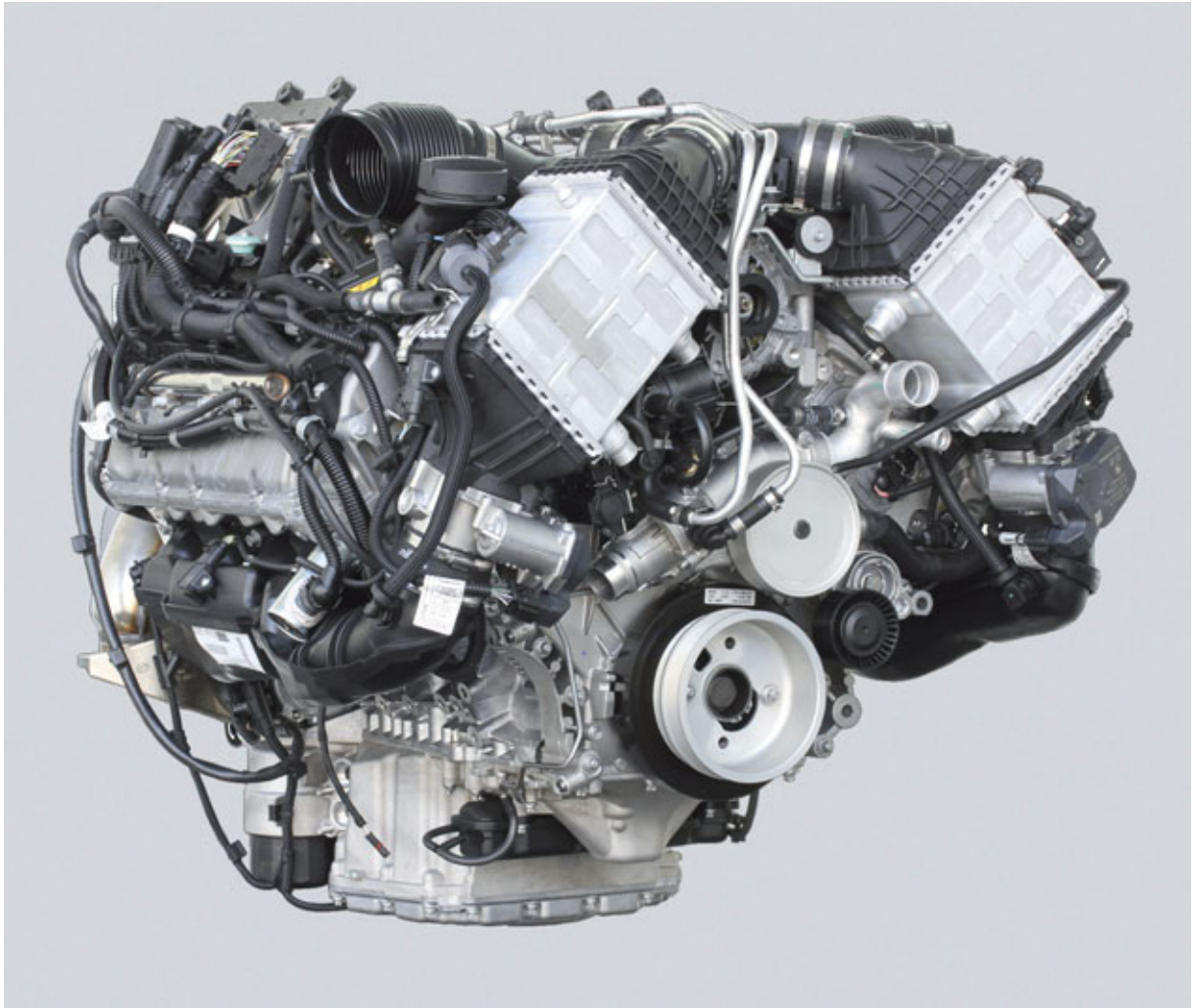

BMW Service

Edited for the U.S. market by:

**BMW Group University
Technical Training**

ST1202

6/1/2012

General information

Symbols used

The following symbol is used in this document to facilitate better comprehension or to draw attention to very important information:



Contains important safety information and information that needs to be observed strictly in order to guarantee the smooth operation of the system.

Information status and national-market versions

BMW Group vehicles meet the requirements of the highest safety and quality standards. Changes in requirements for environmental protection, customer benefits and design render necessary continuous development of systems and components. Consequently, there may be discrepancies between the contents of this document and the vehicles available in the training course.

This document basically relates to the European version of left-hand drive vehicles. Some operating elements or components are arranged differently in right-hand drive vehicles than shown in the graphics in this document. Further differences may arise as the result of the equipment specification in specific markets or countries.

Additional sources of information

Further information on the individual topics can be found in the following:

- Owner's Handbook
- Integrated Service Technical Application.

Contact: conceptinfo@bmw.de

©2011 BMW AG, Munich, Germany

Reprints of this publication or its parts require the written approval of BMW AG, Munich

The information contained in this document forms an integral part of the technical training of the BMW Group and is intended for the trainer and participants in the seminar. Refer to the latest relevant information systems of the BMW Group for any changes/additions to the technical data.

Information status: **September 2011**
VH-23/International Technical Training

S63TU Engine

Contents

1.	Introduction	1
1.1.	Models.....	1
1.2.	Technical data.....	1
1.2.1.	Full load diagram	3
1.3.	New features/Changes/Special Features.....	5
1.4.	Engine identification.....	6
1.4.1.	Engine designation.....	6
1.4.2.	Engine identification.....	6
2.	Engine Components	8
2.1.	Engine housing.....	8
2.1.1.	Crankcase.....	9
2.1.2.	Cylinder head gasket.....	9
2.1.3.	Cylinder head.....	9
2.1.4.	Cylinder head cover.....	11
2.1.5.	Oil pan.....	19
2.2.	Crankshaft drive.....	21
2.2.1.	Crankshaft with bearings.....	21
2.2.2.	Connecting rod with bearing.....	22
2.2.3.	Piston with piston rings.....	23
2.3.	Camshaft drive.....	24
2.4.	Valvetrain.....	25
2.4.1.	Design.....	25
2.4.2.	Valvetronic.....	29
2.5.	Belt drive.....	32
3.	Oil Supply	34
3.1.	Overview.....	34
3.1.1.	S63TU hydraulic circuit diagram.....	35
3.2.	Oil pump and pressure control.....	36
3.2.1.	Oil pump.....	37
3.3.	Oil filtering and cooling.....	38
3.3.1.	Oil cooling.....	38
3.3.2.	Oil filtering.....	38
3.4.	Oil monitoring.....	39
3.4.1.	Oil level.....	39
3.5.	Oil spray nozzles.....	39
3.5.1.	Piston crown cooling.....	39
3.5.2.	Chain drive.....	40
3.5.3.	Camshaft.....	42
3.5.4.	Valvetronic servomotor.....	43

S63TU Engine

Contents

4. Cooling System	44
4.1. System overview	44
4.1.1. Engine cooling circuit	45
4.1.2. Charge air cooler and DME cooling circuit	50
4.2. Heat management	53
4.2.1. Coolant pump	53
4.2.2. Map thermostat	53
5. Air Intake/Exhaust Emission System	54
5.1. Overview	54
5.2. Air intake system	56
5.2.1. Intake silencer	57
5.2.2. Hot film air mass meter	57
5.2.3. Intake manifold	57
5.3. Exhaust turbocharger	58
5.3.1. Function	60
5.4. Exhaust emission system	60
5.4.1. Exhaust manifold	60
5.4.2. Catalytic converter	62
6. Vacuum System	64
7. Fuel Preparation	65
7.1. Overview	65
7.2. Fuel pump control	66
7.3. High-pressure pump	66
7.4. Injectors	67
8. Fuel Supply	68
9. Engine Management System	69
9.1. Overview	69
9.2. Engine control unit	74
9.2.1. Overall function	76

S63TU Engine

1. Introduction

The S63 top (S63TU) engine is installed in the new BMW M5 and M6. It is a further development of the S63 engine from the BMW X5 M and BMW X6 M. The S63 top (S63TU) engine in the BMW M5/M6 is the successor to the extremely successful S85 engine. With this "downsizing" this now becomes a part of the BMW drive strategy of EfficientDynamics for M vehicles. The further development of the S63 top (S63TU) engine to the previous S63 engine is the latest fuel-mixture generation technology Turbo-Valvetronic Direct Injection (TVDI). There are strong similarities here to the N20 and N55 engines. The aim in the development of the S63 top (S63TU) engine was not to achieve a power greater than that of the S63 engine, but to increase the response and rev characteristics, while at the same time reducing the fuel consumption.

In this documentation the differences to the S63 engine are described.

1.1. Models

Model designation	Engine designation	Series introduction
BMW M5/M6	S63B44T0	F12 M6 Convertible June 2012 F10 M5 Sedan and F13 M6 Coupe August 2012

1.2. Technical data

	Unit	S85B5000	S63B4400	S63B44T0
Series		E60	E70/E71	F10/F12/F13
Model designation		BMW M5	BMW X5M/X6M	BMW M5/M6
Design		V10	V8	V8
Displacement	[cm ³]	4999	4395	4395
Firing order		1-6-5-10-2-7-3-8-4-9	1-5-4-8-6-3-7-2	
Bore / Stroke	[mm]	92/75.2	89/88.3	89/88.3
Power output at engine speed	HP [rpm]	500 7750	555 6000	560 6000 - 7000
Cutoff speed	[rpm]	8250	6800	7200
Power output per liter	HP	100	125	127
Torque at engine speed	[Nm/lb-ft] [rpm]	520/383 6100	680/500 1500 - 5650	680/500 1500 - 5750
Compression ratio	[ε]	12.0 to 1	9.3 to 1	10.0 to 1
Valves per cylinder		4	4	4
Fuel	[RON]	95 - 98	95 - 98	95 - 98
CO ₂ emissions	[g/km]	344	325	232
Digital Engine Electronics (DME)		MSS65	MSD85.1	MEVD17.2.8

S63TU Engine

1. Introduction

	Unit	S85B5000	S63B4400	S63B44T0
Exhaust emissions legislation		ULEV II	LEV II	LEV II
Maximum speed	km/h mph	250 155*	250 155*	250 155*
Acceleration 0–60 mph	[s]	4.5	4.5	4.1**
Vehicle curb weight DIN	kg lbs	1,870 4,114	2,305 5,071	1,870 4,114

* Electronically limited

** F13 M6 – 4.1s, F13 M6 – 4.3s and F10 M5 – 4.2s

S63TU Engine

1. Introduction

1.2.1. Full load diagram

BMW F10 M5/E60 M5

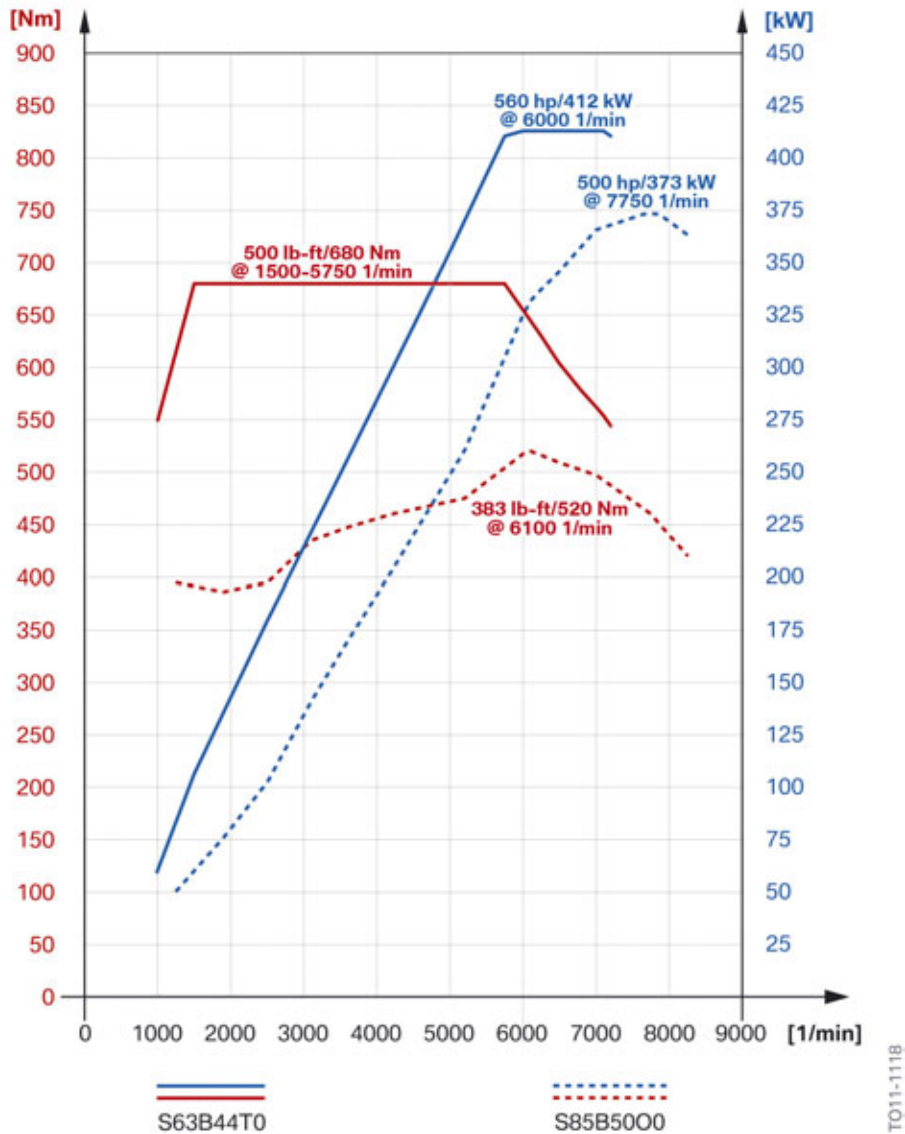

Full load diagram comparing **S63B44T0** engine with **S85B5000** engine

S63TU Engine

1. Introduction

BMW M5/BMW X5 M

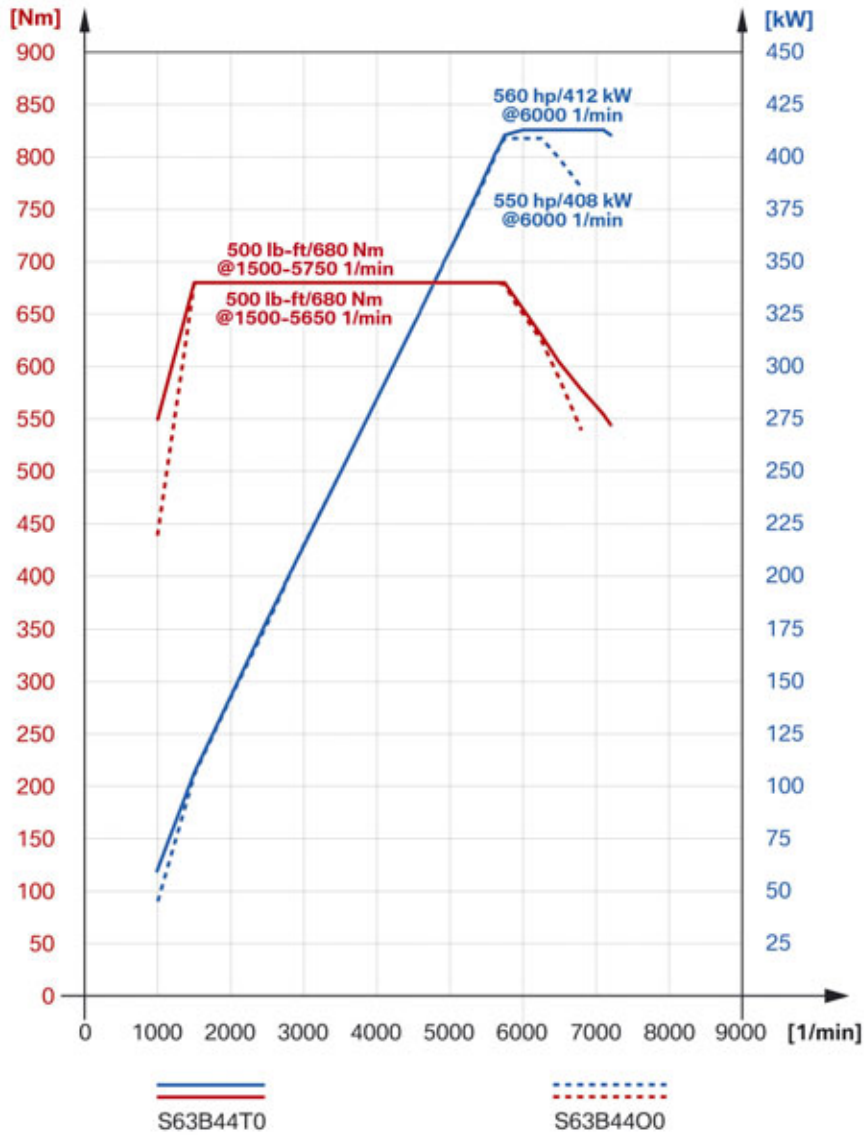

Full load diagram comparing **S63B44T0** engine with **S63B44O0** engine

TO11-1119

S63TU Engine

1. Introduction

1.3. New features/Changes/Special Features

System	Comment
Engine mechanics	<ul style="list-style-type: none">• New cylinder head due to use of the Turbo-Valvetronic direct injection (TVDI) procedure• 3rd generation Valvetronic• New Valvetrain• New variable camshaft timing control (VANOS)• New cylinder head cover with adapted crankcase ventilation• New pistons• New connecting rods with even pitch• New crankshaft• Optimized belt drive for higher speed
Oil supply	<ul style="list-style-type: none">• Oil pump with intake and compression stage (G rotor and pendulum slide cell pump)• New oil spray nozzles.
Cooling	<ul style="list-style-type: none">• Modified coolant pump for increased flow rate• Electric coolant pumps for exhaust turbocharger, charge air cooling and DME (Digital Engine Electronics)
Air intake and exhaust emission systems	<ul style="list-style-type: none">• optimized air intake system• TwinScroll exhaust turbocharger with multi-bank exhaust manifold• Hot film air mass meter 7.
Vacuum system	<ul style="list-style-type: none">• Two-stage vacuum pump with new arrangement of the screw connection• Vacuum reservoir for the wastegate valves below the oil pan.
Fuel preparation	<ul style="list-style-type: none">• High-pressure injection (like N55 engine)• Solenoid valve injectors• Bosch high-pressure pump.
Engine electrical system	<ul style="list-style-type: none">• Two engine control units, mounted to top of engine and cooled by coolant.

S63TU Engine

1. Introduction

1.4. Engine identification

1.4.1. Engine designation

The engine designation S63B44T0 is used to ensure proper identification of the engine.

Explanation

Index	Explanation
S	BMW M GmbH development
6	V8 engine
3	Engine with exhaust turbocharger, Valvetronic and direct fuel injection (TVDI)
B	Gas engine, longitudinally installed
44	4.4 liters displacement
T	Top performance class
0	New development

In the engine designation **S63B44T0** the **T** stands for “**Top performance class**” thus some material may refer to this engine as the **S63 top** and it also may be referred to as **S63TU** (in marketing terms).

This document contains the short form of the engine designation **S63 top (S63TU)**, which only indicates the engine type.

1.4.2. Engine identification

The engines have an identification mark on the crankcase to ensure proper identification and classification. The first six positions of the engine identification correspond to the engine designation.

The engine number can be found on the engine above the engine identification. This consecutive number, in conjunction with the engine identification, allows proper identification of each individual engine.

S63TU Engine

1. Introduction

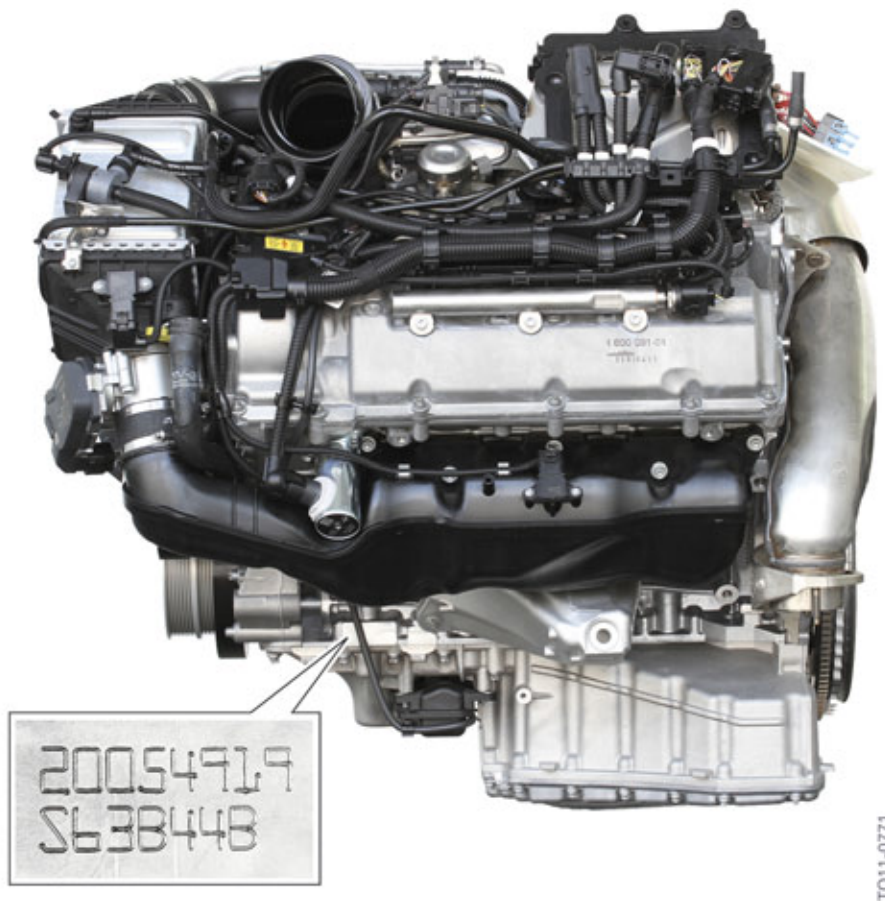

S63 top (S63TU) engine identification and engine number

Index	Explanation
20054919	Individual consecutive engine number
S	BMW M GmbH development
6	V8 engine
3	Engine with exhaust turbocharger, Valvetronic and direct fuel injection (TVDI)
B	Gas engine, longitudinally installed
44	4.4 liters displacement
B	Type test concerns, standard

S63TU Engine

2. Engine Components

2.1. Engine housing

The engine housing consists of the engine block, cylinder heads, cylinder head covers, oil pan and the gaskets.

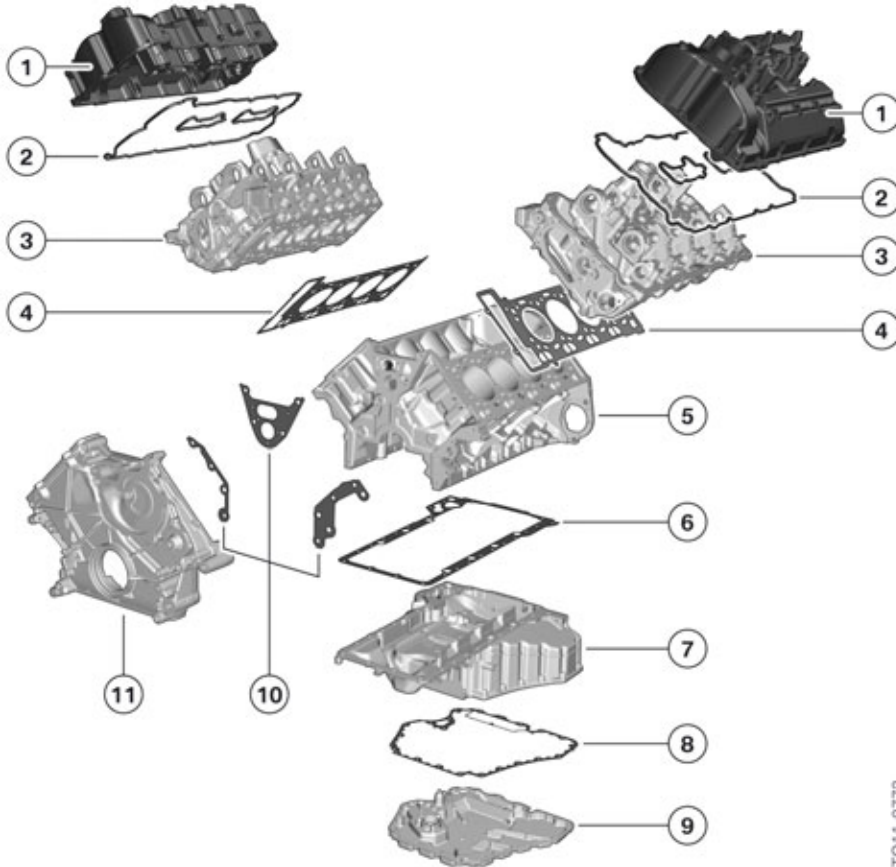

TO11-077Z

S63 top (S63TU) engine, structure of engine housing

Index	Explanation
1	Cylinder head cover
2	Cylinder head cover gasket
3	Cylinder head
4	Cylinder head gasket
5	Crankcase
6	Gasket for upper part of crankcase
7	Upper part of oil pan
8	Gasket for lower part of oil pan
9	Lower part of oil pan
10	Gasket for chain case
11	Chain case cover

S63TU Engine

2. Engine Components

2.1.1. Crankcase

The crankcase is manufactured from die-cast aluminium GL-AISi917Cu4MG, similar to the S63 engine. The cylinder walls are made from Alusil. The crankcase was optimized for the specific M requirements.

2.1.2. Cylinder head gasket

A three-layer spring steel gasket is used for the cylinder head gasket. There is a stopper plate (2) in the area of the cylinder bores in order to achieve sufficient contact pressure for sealing. The contact surfaces for the cylinder head and the engine block are layered and have a partial fluorocarbon coating with anti-stick coating.

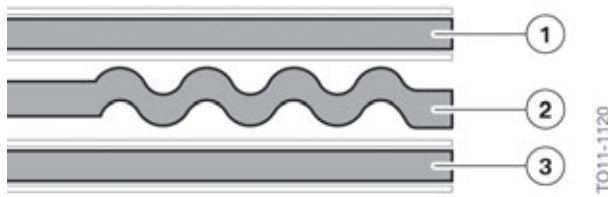

Cylinder head gasket

Index	Explanation
1	Top spring steel layer with anti-stick coating
2	Stopper plate
3	Bottom spring steel layer with anti-stick coating

2.1.3. Cylinder head

The cylinder head of the S63 top (S63TU) engine is a new development with integrated air ducts for the crankcase ventilation.

3rd generation Valvetronic is also used in the S63 top (S63TU) engine, similar to the N55 engine. The Valvetronic servomotor is connected on the outside of the cylinder head.



The combination of exhaust turbocharger, Valvetronic and direct fuel injection is known as **Turbo Valvetronic Direct Injection (TVDI)**.

S63TU Engine

2. Engine Components

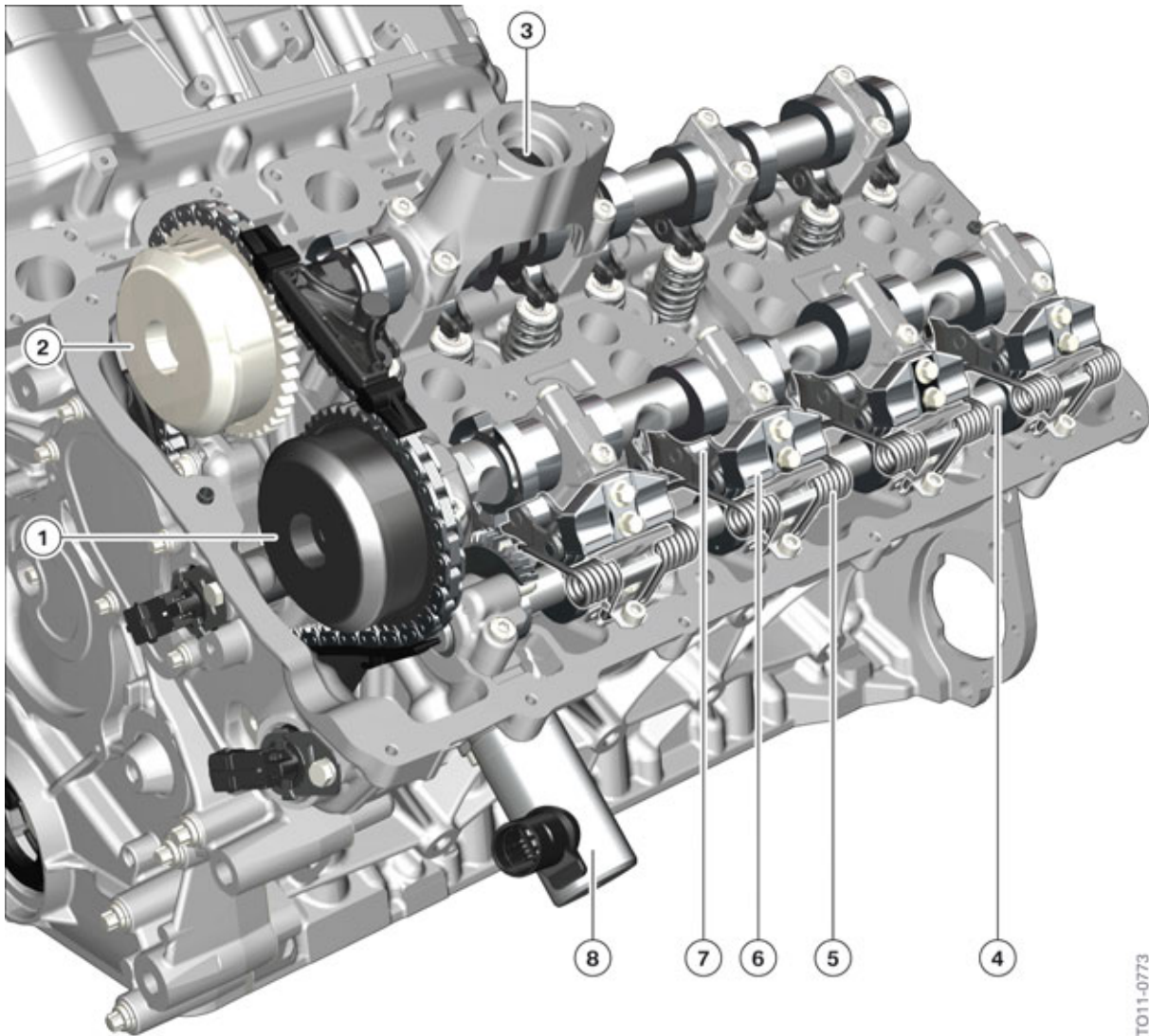

Cylinder head

TO11-0773

Index	Explanation
1	VANOS, intake side
2	VANOS, exhaust side
3	Roller tappet, high-pressure pump
4	Eccentric shaft
5	Spring
6	Guide block
7	Intermediate lever
8	Valvetronic servomotor

S63TU Engine

2. Engine Components

2.1.4. Cylinder head cover

Design

The cylinder head cover is a new design with integrated crankcase ventilation and line routing. The operating principle of the crankcase ventilation is from the N63 engine. A separate line from the crankcase ventilation system to the air intake system is not used on the S63 top (S63TU) engine. Separate bore holes for the individual intake ports are integrated in the cylinder head. Every bank has its own crankcase ventilation ducts.

The camshaft sensors are positioned on the front of the cylinder head cover.

To separate the oil in the blow-by gasses, a labyrinth oil separator is used. A pre-separator (5) and a impact plate with small air vents (4) are in the flow direction. The oil drops are separated at these barriers and return to the cylinder head via the return line (7+8). An impact surface (3) with an upstream filter ensures further separation of oil particles. The oil return (8) is equipped with a non-return valve in order to prevent direct intake of blow-by gasses without separation. If the oil level increases in this pipe, the non-return valve opens the oil drops into the cylinder head. Finally the cleaned blow-by gasses are re-fed into the intake system depending on the operating condition of the engine via the non-return valve (1) or via the volume control valve (10).

S63TU Engine

2. Engine Components

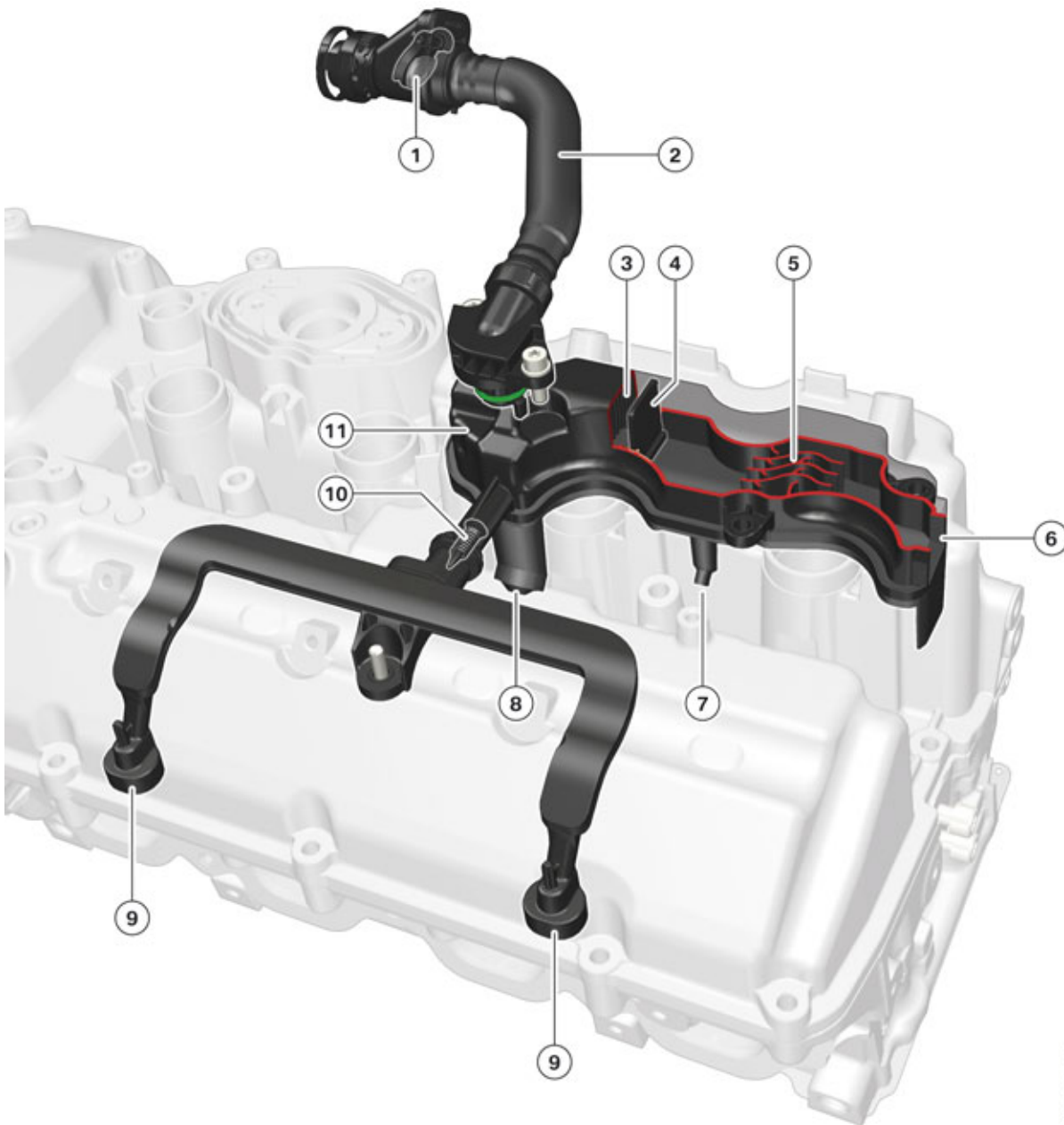

TO11-1129

Cylinder head cover with crankcase ventilation

Index	Explanation
1	Non-return valve for the clean air pipe with leak hole
2	Line to clean air pipe
3	Impact surface with upstream filter
4	Fine impact plate with small air vents
5	Pre-separator
6	Intake for blow-by gases

S63TU Engine

2. Engine Components

Index	Explanation
7	Oil return
8	Oil return with non-return valve
9	Connecting line via blow-by-gas channel for the intake port
10	Volume control valve for the air intake system with throttle function
11	Oil separator

Crankcase ventilation in naturally aspirated engine operation

In the naturally aspirated engine operation there is a vacuum in the air intake system (2). The volume control valve (15) is opened and the cleaned blow-by gases make their way to the intake ports via bore holes in the cylinder head and into the air intake system. As there is a risk that oil may be drawn in by the crankcase ventilation in the case of an increase of vacuum, the volume control valve (15) has a throttle function which limits the blow-by gas flow along with the pressure level in the crankcase.

The vacuum in the crankcase ventilation keeps the non-return valve (12) closed. Additional fresh air flows into the oil separator via an overlying leak hole (13). This does not allow the vacuum in the crankcase to go above a maximum of 100 mbar.

S63TU Engine

2. Engine Components

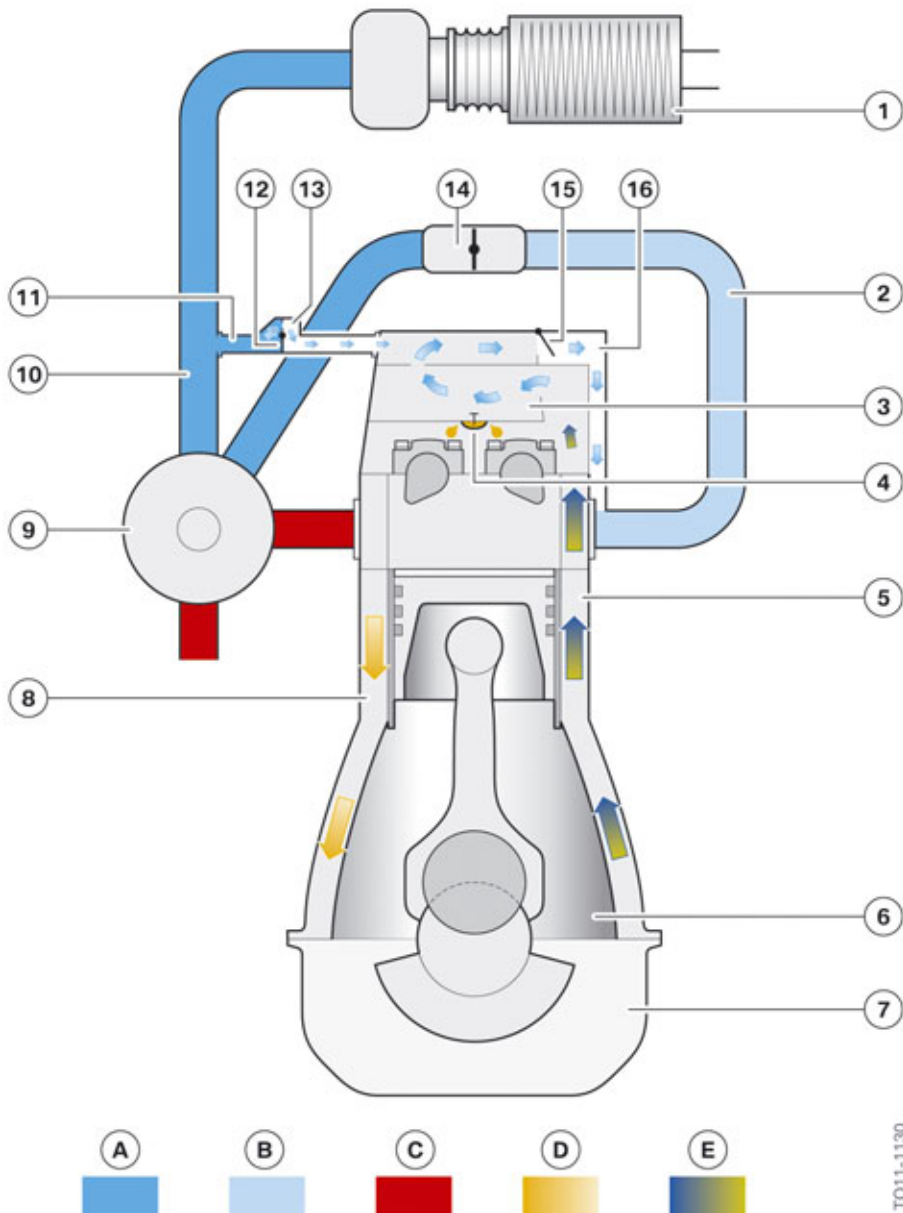

Crankcase ventilation in the naturally aspirated engine operation

Index	Explanation
A	High pressure
B	Vacuum
C	Exhaust gas
D	Oil
E	Blow-by gases
1	Air filter
2	Intake manifold

S63TU Engine

2. Engine Components

Index	Explanation
3	Oil separator
4	Oil discharge
5	Ventilation duct
6	Crank chamber
7	Oil pan
8	Oil return duct
9	Exhaust turbocharger
10	Clean air pipe
11	Line to clean air pipe
12	Non-return valve for the clean air pipe
13	Leak hole
14	Throttle valve
15	Volume control valve for the air intake system with throttle function
16	Channel in the cylinder head

S63TU Engine

2. Engine Components

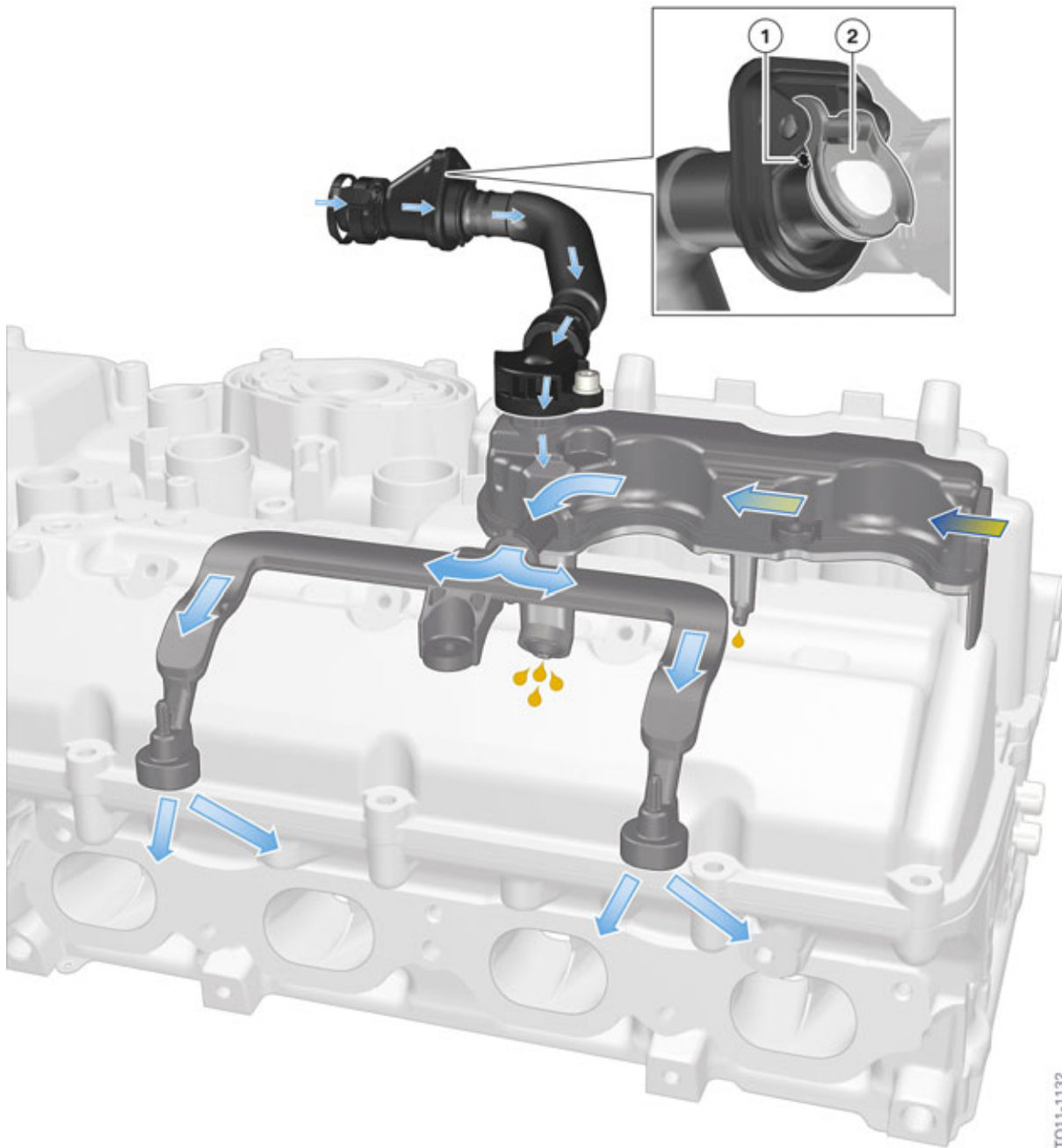

TO11-1132

Ventilation in the naturally aspirated engine operation

Index	Explanation
1	Leak hole
2	Non-return valve

S63TU Engine

2. Engine Components

Index	Explanation
A	High pressure
B	Vacuum
C	Exhaust gas
D	Oil
E	Blow-by gases
1	Air filter
2	Intake manifold
3	Oil separator
4	Oil discharge
5	Ventilation duct
6	Crank chamber
7	Oil pan
8	Oil return duct
9	Exhaust turbocharger
10	Clean air pipe
11	Line to clean air pipe
12	Non-return valve for the clean air pipe
13	Leak hole in the housing of the non-return valve
14	Throttle valve
15	Volume control valve for the air intake system with throttle function
16	Channel in the cylinder head

S63TU Engine

2. Engine Components

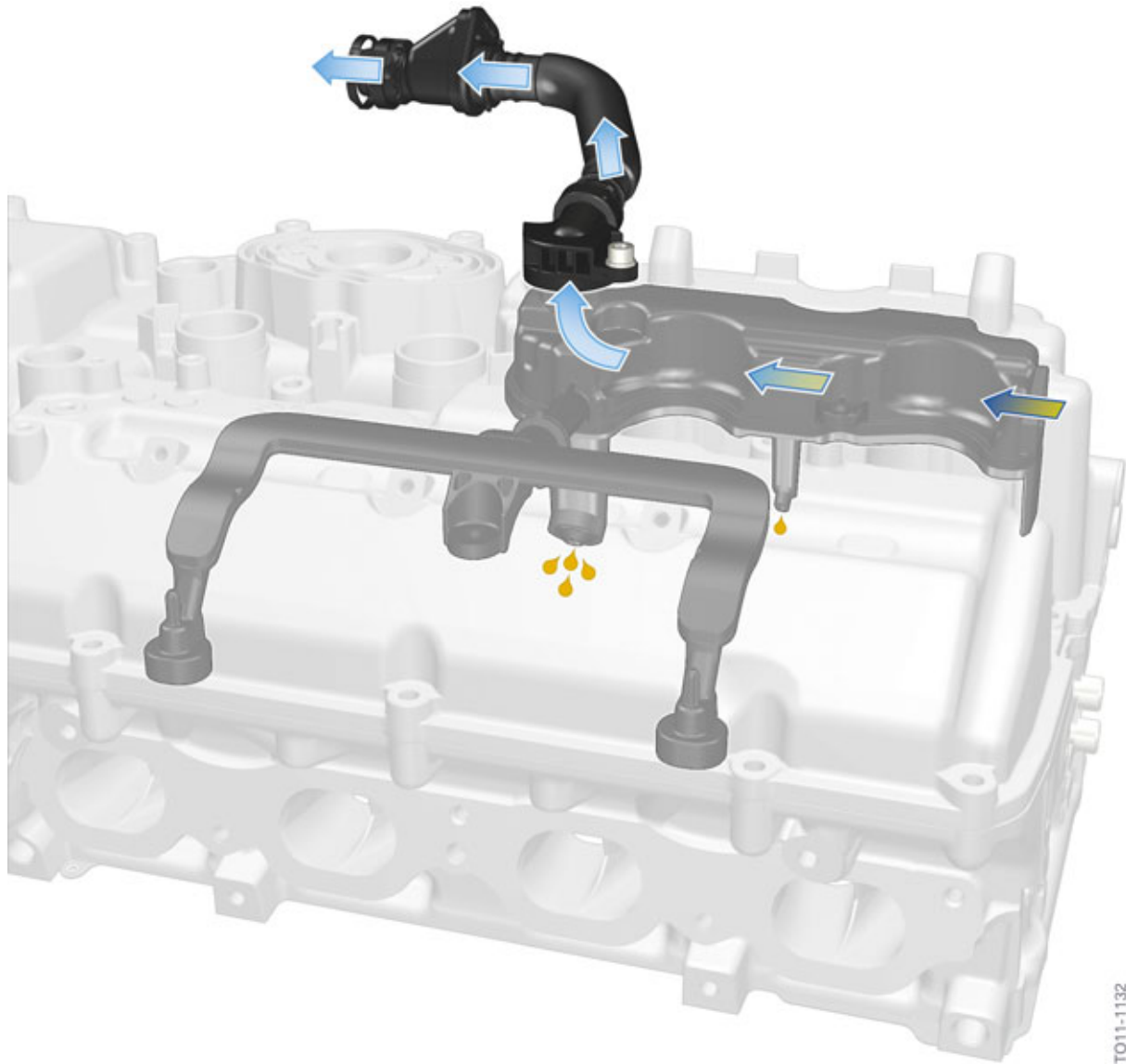

Crankcase ventilation in boost mode

2.1.5. Oil pan

The oil pan is made from aluminium. Like the S63 engine, it is made up of two parts. The oil filter is integrated in the upper oil pan section.

The oil pump is bolted to the upper oil pan section and driven by a chain by the crankshaft. To avoid engine oil foaming, the drive chain and the shaft sprocket are separated from the oil by the oil pan. The oil deflector is integrated in the upper oil pan section. The oil drain plug is not used in the oil filter cover.

S63TU Engine

2. Engine Components

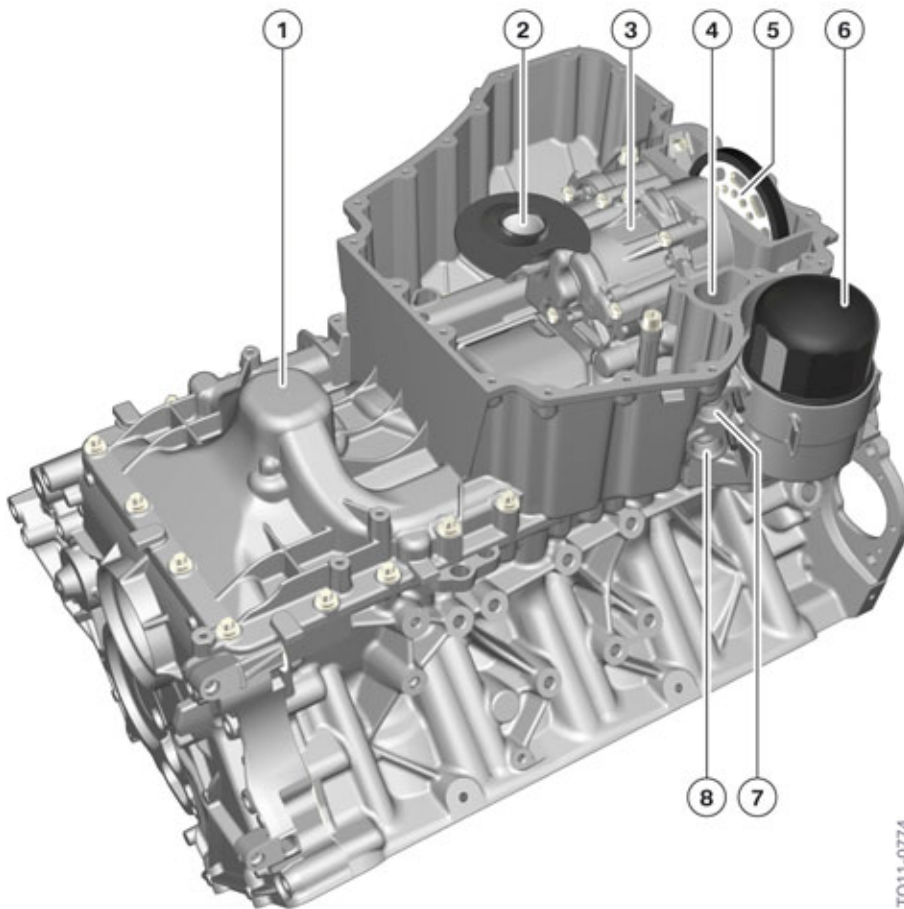

Upper oil pan section with oil pump

Index	Explanation
1	Oil return pipe
2	Intake pipe for the pressure pump
3	G rotor and pendulum slide cell pump
4	Thermostat
5	Chain drive of the crankshaft
6	Oil filter cover without oil drain plug
7	Connection from oil cooler
8	Connection to oil cooler

S63TU Engine

2. Engine Components

2.2. Crankshaft drive

2.2.1. Crankshaft with bearings

Crankshaft

The crankshaft of the S63 top (S63TU) engine has a stroke of 88.3 mm and is forged steel (C38) with a hardened surface layer and 6 balance weights.

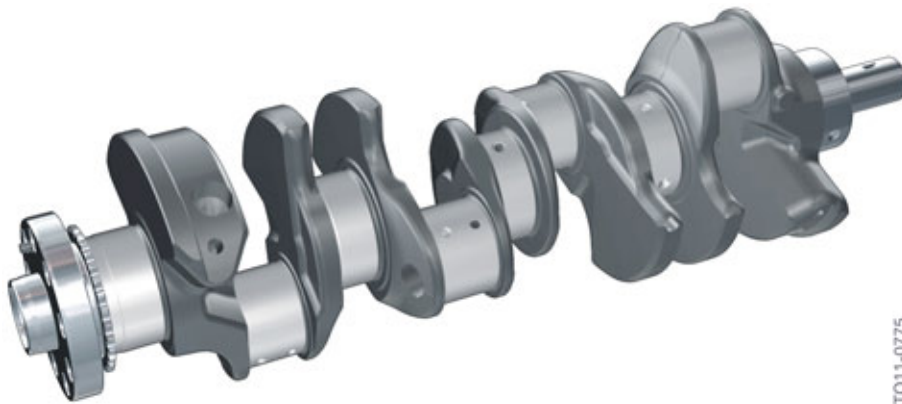

TO11-0775

S63 top (S63TU) crankshaft

Crankshaft bearings

The crankshaft is supported by five bearings. The two-material thrust bearing is located in the middle at the third bearing position. Lead-free three-material bearings are used.

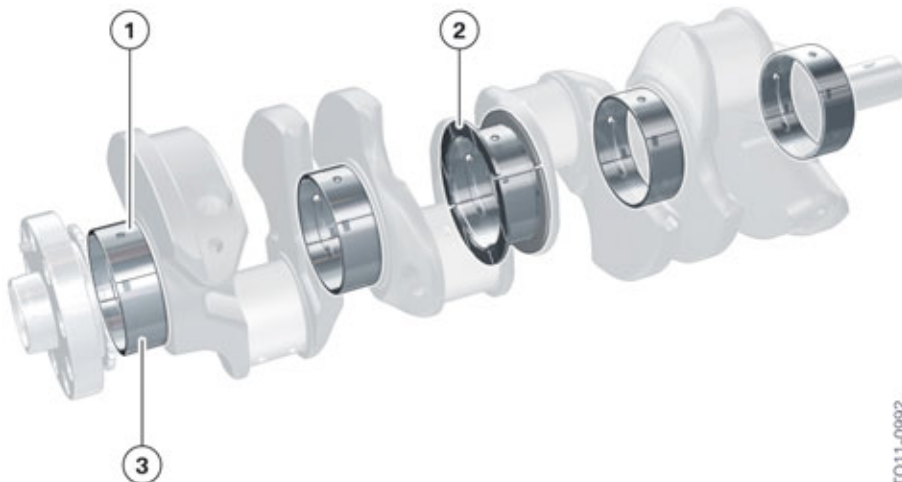

TO11-0992

S63 top (S63TU) crankshaft bearings

S63TU Engine

2. Engine Components

Index	Explanation
1	Upper bearing shell with groove and oil hole
2	Thrust bearing with groove and oil hole
3	Lower bearing shell without groove



The identification markings for the bearings are stamped on the crankcase and on the crankshaft. Refer to the repair instructions if the crankshaft is to be fitted with new bearings.

2.2.2. Connecting rod with bearing

Connecting rod

The connecting rod of the S63 top (S63TU) engine has been redesigned. It is a cracked and forged connecting rod with a trapezoidal design. In the small end of the connecting rod with a formed hole is used like in the N20 and N55 engine. The force is evenly distributed over a larger area and the load on the edges of the rod bushings is reduced considerably.

S63TU Engine

2. Engine Components



TO11-0776

Connecting rod

Bearings

Lead-free connecting rod bearing shells are used. A bearing pair with the colors red/blue are used as standard. The blue bearing is on the rod side, the red bearing on the cap side.

2.2.3. Piston with piston rings

Mahle cast pistons are used. The piston crown shape is adapted accordingly to the combustion processes, the valve reliefs in the piston crown and the use of the injectors with multiple nozzles.

S63TU Engine

2. Engine Components



TO11-0777

Cast piston

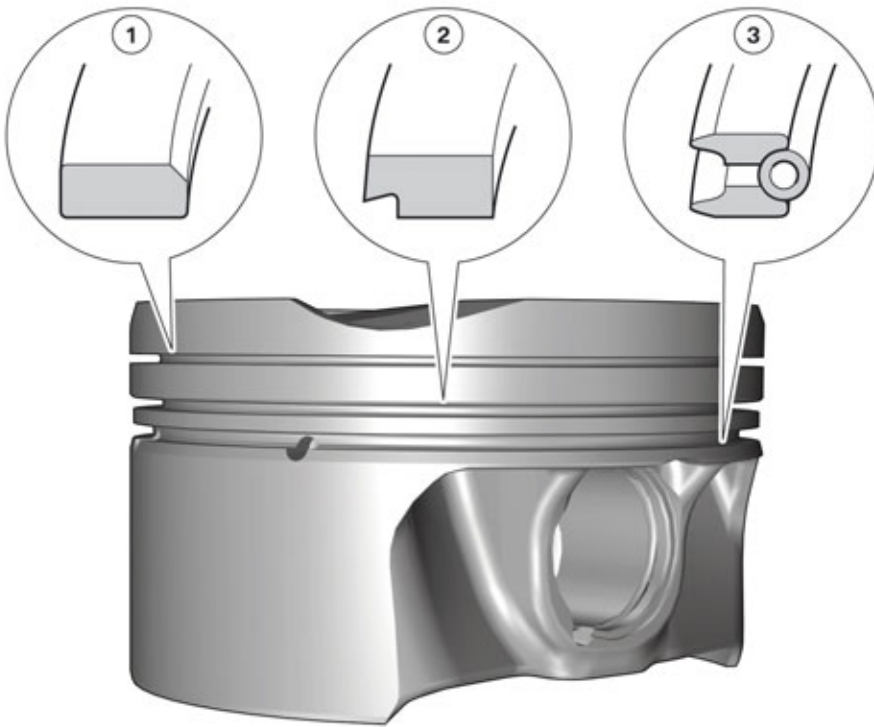

TO11-0778

Piston rings

Index	Explanation
1	Plain rectangular compression ring with ball-shaped (B-ring)
2	Taper faced piston ring (NM-ring)
3	Oil scraper ring with spiral expander (DSF-ring)

2.3. Camshaft drive

The camshaft drive has been redesigned. The drive chain uses a toothed roller-type chain.

S63TU Engine

2. Engine Components

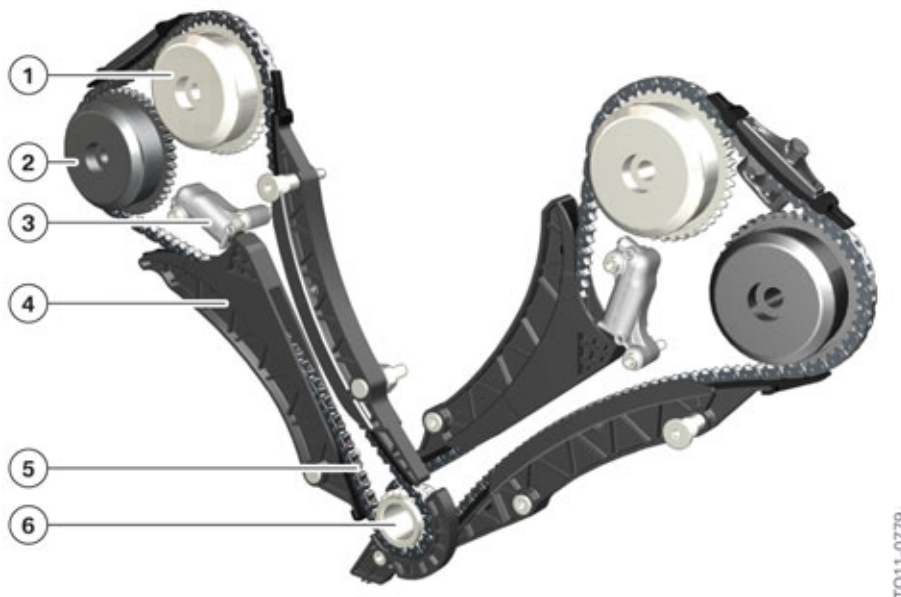

Camshaft drive

Index	Explanation
1	VANOS, exhaust side
2	VANOS, intake side
3	Chain tensioner
4	Tensioning rail
5	Tooth-type chain
6	Crankshaft gear

2.4. Valvetrain

2.4.1. Design

In the S63 top (S63TU) engine the fully variable valve lift control (VVT) is now used in addition to double VANOS. The valvetrain itself comprises of already known components. A roller-type chain is used per bank for the drive of the camshafts. The chain tensioner and slide rails are common parts for both banks. The oil spray nozzles are integrated in the chain tensioner. For servicing the cams or any part of the valvetrain, the S63 top (S63TU) engine is not pinned at TDC of the cylinder, but at 150° before firing TDC of cylinder #1. For locking the engine in this position a special tool is positioned on the torsional vibration damper, which is used as a reference for the alignment pin for the crankcase.

S63TU Engine

2. Engine Components

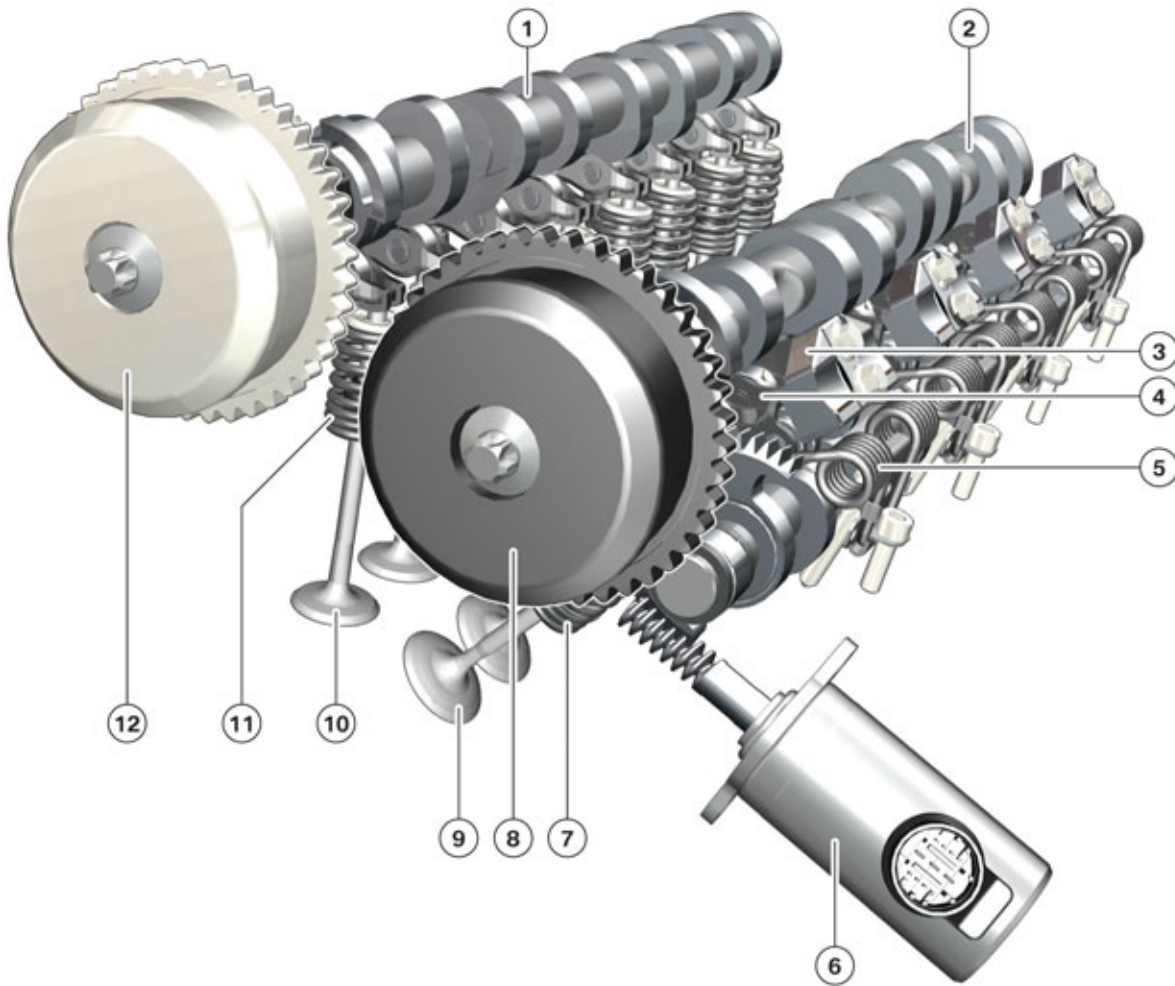

TO11-0780

Valvetrain

Index	Explanation
1	Exhaust camshaft
2	Intake camshaft
3	Guide plate
4	Intermediate lever
5	Spring
6	Valvetronic servomotor
7	Valve spring, intake valve
8	VANOS, intake side
9	Intake valve
10	Exhaust valve
11	Valve spring, exhaust valve
12	VANOS, exhaust side

S63TU Engine

2. Engine Components

Camshafts

The S63 top (S63TU) engine has the same lightweight camshafts as in the S63 engine. All components are fixed to the shaft by the inner high-pressure metal forming.

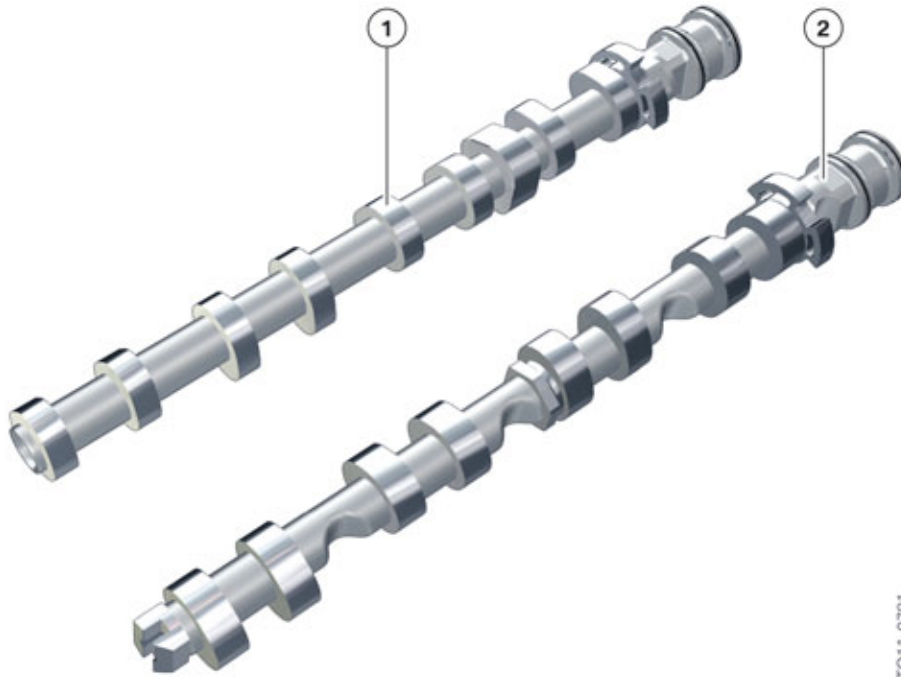

TO11-0781

S63 top (S63TU) camshafts

Index	Explanation
1	Exhaust camshaft
2	Intake camshaft

S63TU Engine

2. Engine Components

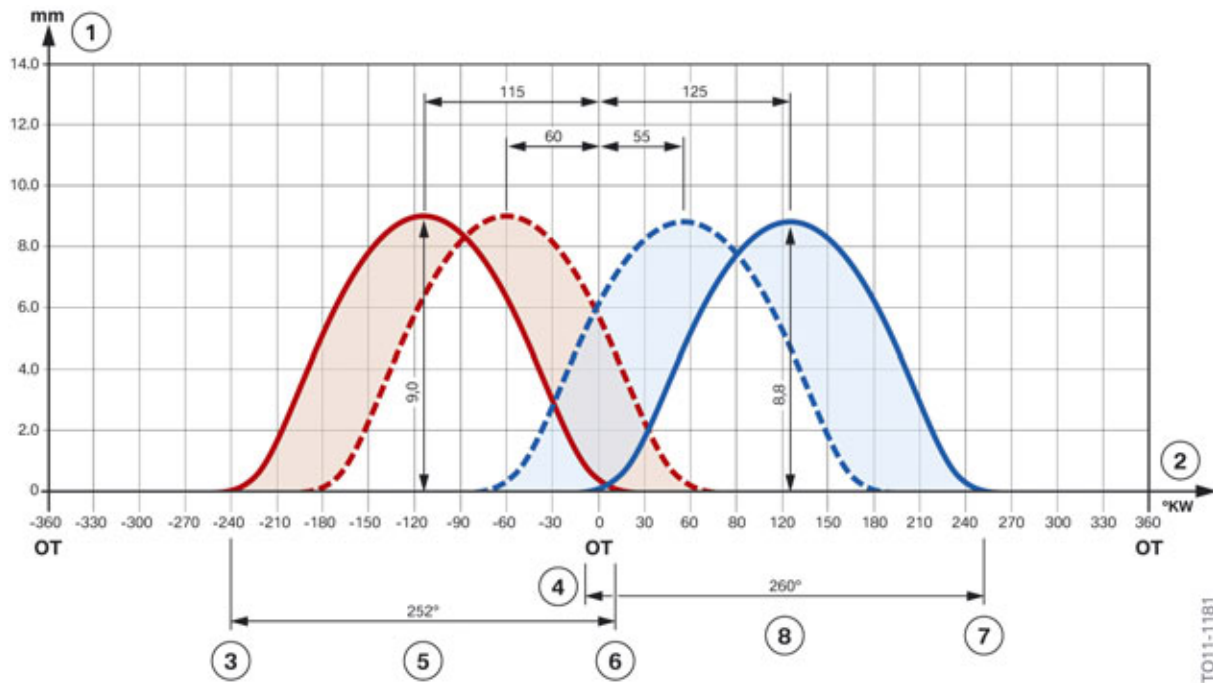

S63 top (S63TU) cam lift and duration

Index	Explanation
1	Valve lift [mm]
2	Crankshaft degrees [°KW]
3	Exhaust valve open
4	Intake valve open
5	Opening period of exhaust valve
6	Exhaust valve closes
7	Intake valve closes
8	Opening period of intake valve

Technical data of valvetrain

		S85B5000	S63B4400	S63B44T0
Intake valve diameter / stem diameter	[mm]	35/5	33.2/6	33.2/6
Exhaust valve diameter / stem diameter	[mm]	30.5/5	29/6	29/6
Maximum valve lift, intake/exhaust valve	[mm]	11.7/11.5	8.8/9.0	8.8/9.0
VANOS adjustment range, intake	[crankshaft degrees]	66	50	70
VANOS adjustment range, exhaust	[crankshaft degrees]	37	50	55

S63TU Engine

2. Engine Components

Spread, intake camshaft	[crankshaft degrees]	79–145	70–120	55–125
Spread, exhaust camshaft	[crankshaft degrees]	91–128	73.5–123.5	60–115
Opening period, intake camshaft	[crankshaft degrees]	268	231	260
Opening period, exhaust camshaft	[crankshaft degrees]	260	252	252

Intake and exhaust valves

The inlet and exhaust valves both have a stem diameter of 6 mm. The exhaust valves are hollow and filled with sodium. This results in improved and quicker heat dissipation.

2.4.2. Valvetronic



The Valvetronic is fully variable valve lift control and variable camshaft control (double VANOS), which makes the closing time of the intake valves adjustable.

Valve lift control is performed on the intake side, while camshaft control is performed on both the intake and exhaust sides.

Throttle-free load control is only possible if:

- the lift of the intake valve
- and camshaft adjustment of the intake and exhaust camshafts are variably controllable.

Result:

The opening and closing times and the opening period and the lift of the intake valve are adjustable.

VANOS

The VANOS (variable camshaft timing control) components of taken from the N55 engine. The differences between the S63 and S63TU engine are:

- The adjustment range of the variable camshaft timing control (VANOS) was increased from 50° to 70° through the use of four instead of five flanks.
- The weight was reduced from 1050 g to 650 g (2.31 lbs to 1.43 lbs) through the use of aluminium instead of steel.

S63TU Engine

2. Engine Components

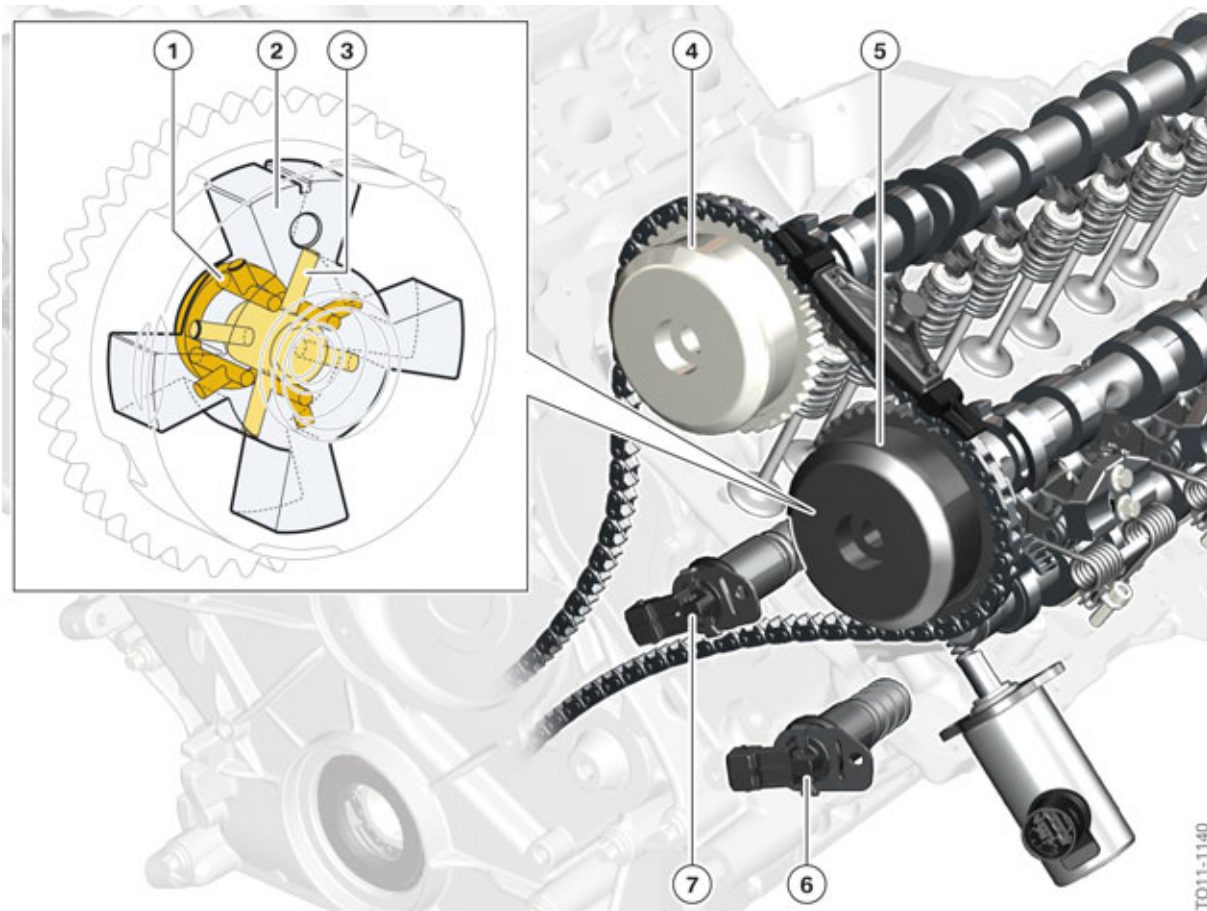

TO11-1140

Variable camshaft timing control (VANOS) with oil supply

Index	Explanation
1	Oil duct for timing advance
2	Rotor
3	Oil duct for timing retard
4	VANOS, exhaust side
5	VANOS, intake side
6	VANOS solenoid valve, intake side
7	VANOS solenoid valve, exhaust side

Valve lift control

The Valvetronic servomotor is attached at the intake side to the cylinder head. The eccentric shaft sensor is integrated in the Valvetronic servomotor.

The system uses Valvetronic III, which is already used in the N55 engine.

S63TU Engine

2. Engine Components

The roller cam followers on the intake side are made from sheet metal and subdivided into five classes, Class "1" to Class "5". The intermediate levers are also made from sheet metal and subdivided into six classes, Class "00" to Class "05".

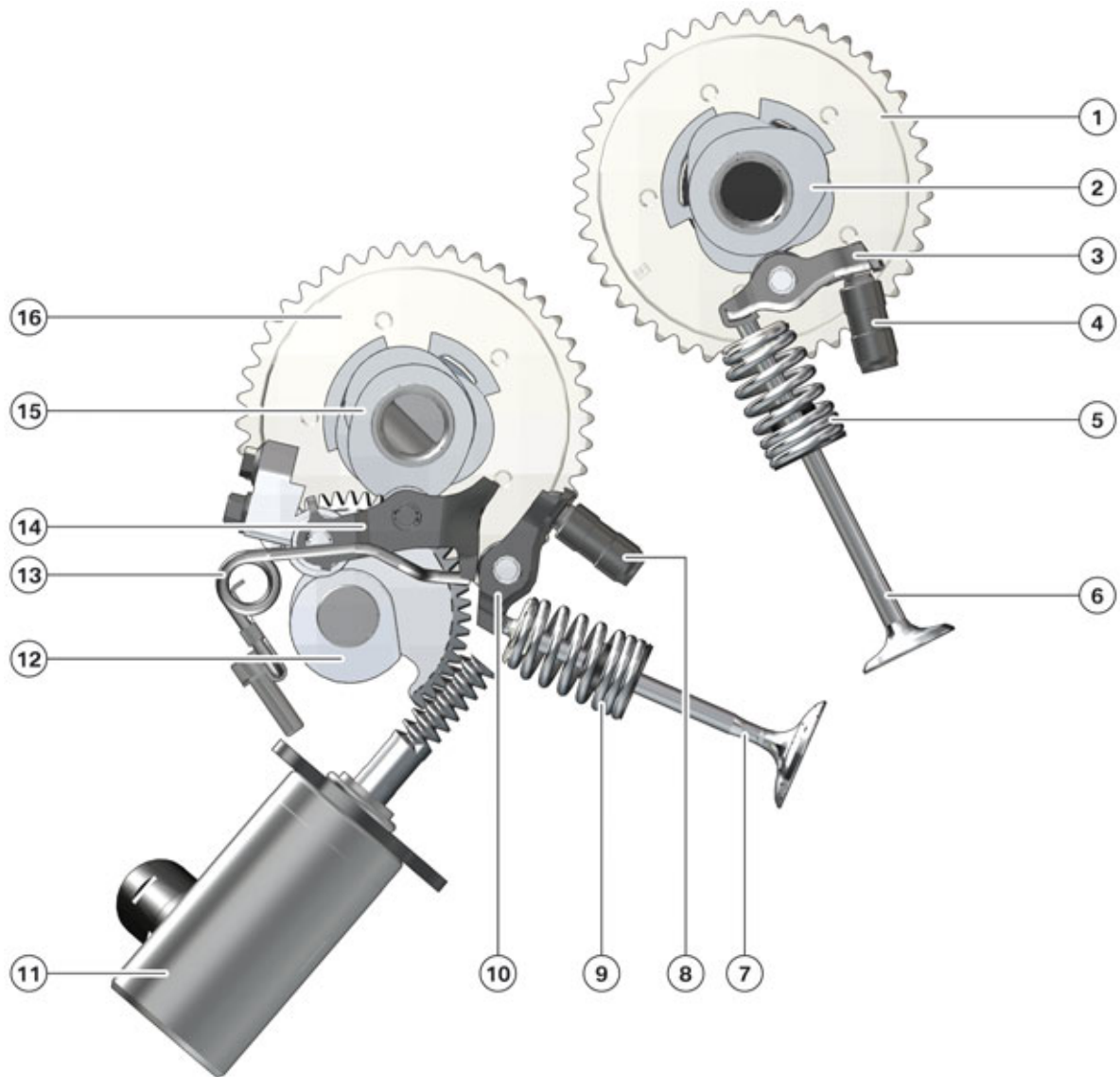

T011-1141

Valve lift control

Index	Explanation
1	VANOS, exhaust side
2	Exhaust camshaft
3	Roller cam follower
4	Hydraulic valve clearance compensation HVCC
5	Valve spring on exhaust side
6	Exhaust valve

S63TU Engine

2. Engine Components

Index	Explanation
7	Intake valve
8	Hydraulic valve clearance compensation HVCC
9	Valve spring on intake side
10	Roller cam follower
11	Valvetronic servomotor
12	Eccentric shaft
13	Spring
14	Intermediate lever
15	Intake camshaft
16	VANOS, intake side

2.5. Belt drive

The belt drive does not have any major changes, only the drive belt and the belt pulley on the crankshaft have a smaller diameter due to the higher engine speed.

The belt drive includes a main belt drive with an alternator, coolant pump and power steering pump. The main belt drive uses a mechanical tensioning pulley.

The secondary belt drive includes the air conditioning compressor and is equipped with an elastic belt. The crankshaft pulley tensioning system from the S63 engine is used for replacing the elastic belt.

S63TU Engine

2. Engine Components

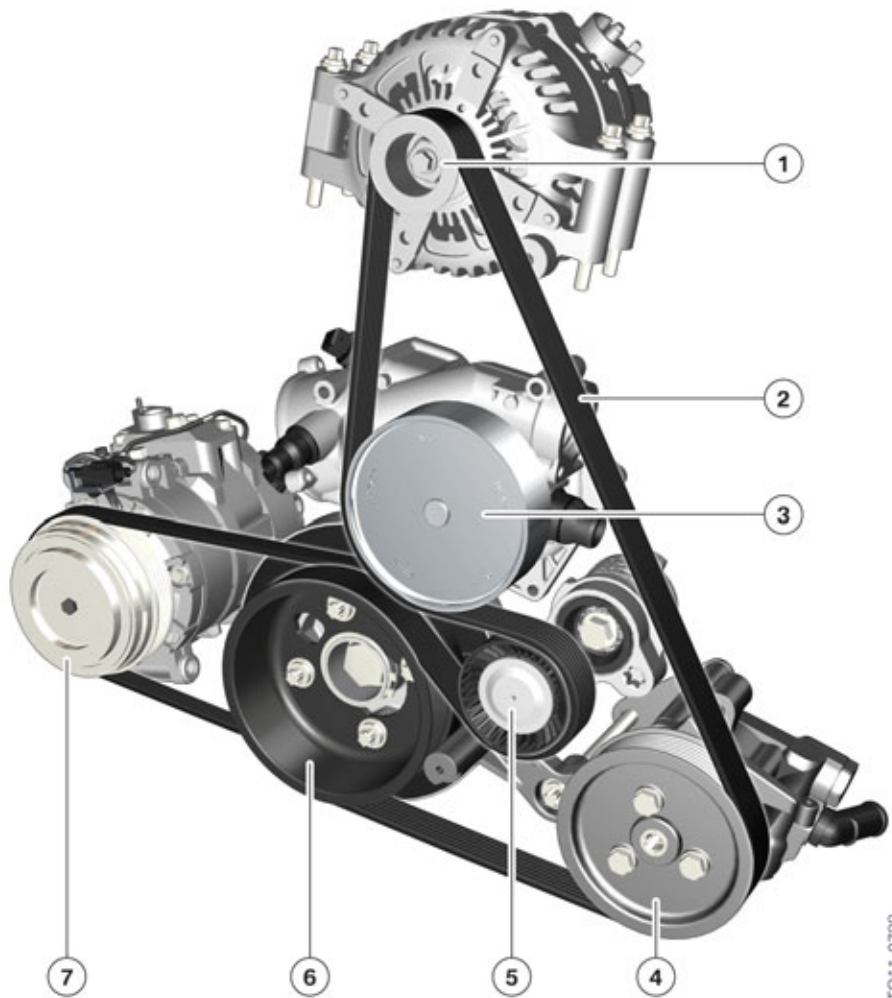

S63 top (S63TU) belt drive

Index	Explanation
1	Belt pulley, alternator
2	Belt
3	Coolant pump belt pulley
4	Belt pulley, power steering pump
5	Belt tensioner
6	Belt pulley, crankshaft
7	Belt pulley, A/C compressor

S63TU Engine

3. Oil Supply

Extremely high deceleration values can occur while braking with the M5/M6 . This can push the engine oil to the front area of the oil pan.

In this case, the pendulum slide cell pump can no longer guarantee the oil supply of the engine due to no oil available at the inlet side of the pump.

For this reason an oil pump with an intake and pressure stage (G-rotor and pendulum slide cell pump) are used for the S63 top (S63TU) engine.

The special features of the oil supply in the S63 top (S63TU) engine are:

- Two-stage oil pump
- Tensioning rail for the oil pump drive
- Additional intake pipe.

3.1. Overview

The following graphic provides an overview of the oil supply and shows the hydraulic oil circuit diagram and the actual layout of the oil ducts in the engine.

S63TU Engine

3. Oil Supply

3.1.1. S63TU hydraulic circuit diagram

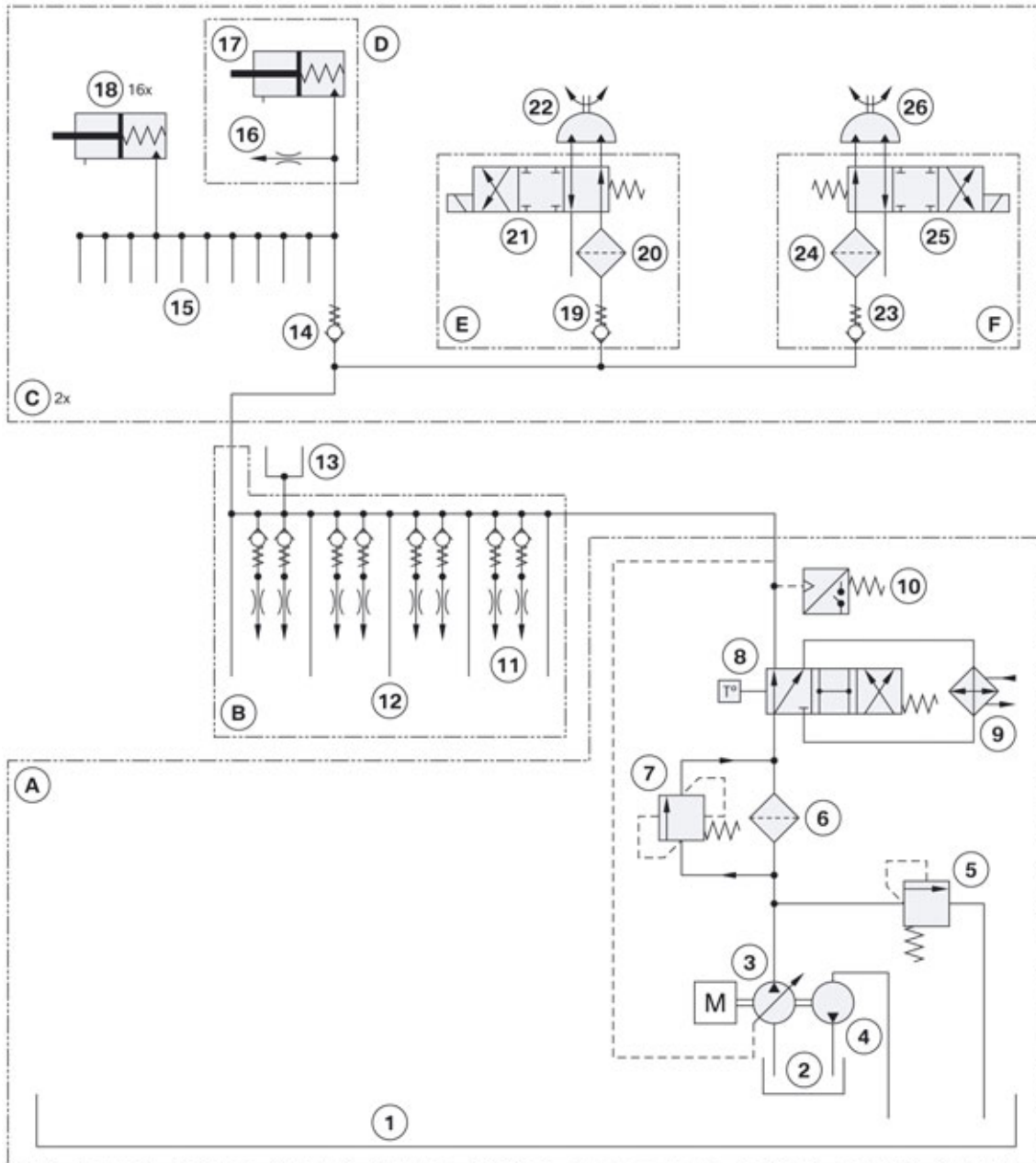

S63 top (S63TU) hydraulic circuit diagram

TO11-0033

Index	Explanation
A	Oil pan
B	Crankcase
C	Cylinder head 2 x
D	Chain tensioner

S63TU Engine

3. Oil Supply

Index	Explanation
E	VANOS, intake side
F	VANOS, exhaust side
1	Oil pan
2	Oil pan in the oil pump area
3	Volume-flow-controlled pendulum slide cell pump
4	G-rotor oil pump
5	Pressure-limiting valve
6	Oil filter
7	Filter bypass valve
8	Thermostat
9	Oil cooler (oil-air heat exchanger)
10	Oil pressure switch
11	Oil spray nozzles for piston crown cooling
12	Lubrication point on crankshaft main bearing
13	Lubrication points on exhaust turbocharger
14	Non-return valve, cylinder head
15	Lubrication points on camshaft bearing
16	Oil spray nozzle for timing chain
17	Chain tensioner
18	Hydraulic valve clearance compensating elements (16 x)
19	Non-return valve
20	Strainer
21	Solenoid valve
22	Swivel motor
23	Non-return valve
24	Strainer
25	Solenoid valve
26	Swivel motor

3.2. Oil pump and pressure control

The S63 top (S63TU) engine has an volume-flow-controlled oil pump with intake and pressure stage in the one housing. The oil pump is fixed to the upper oil pan section.

A rotor style pump is used as an intake stage, which transfers the engine oil from the front area of the oil pan to the rear area of the oil pan by an additional intake pipe.

S63TU Engine

3. Oil Supply

To supply the engine with oil pressure the known volume-flow-controlled pendulum slide cell pump is used. The intake pipe is positioned deep in the rear area of the oil pan to guarantee a definite oil supply.

Information on the operating principle of a volume-flow-controlled oil pump can be found in the ST501 New Engine Technology "N63 Engine training material" available on ICP and TIS.

3.2.1. Oil pump

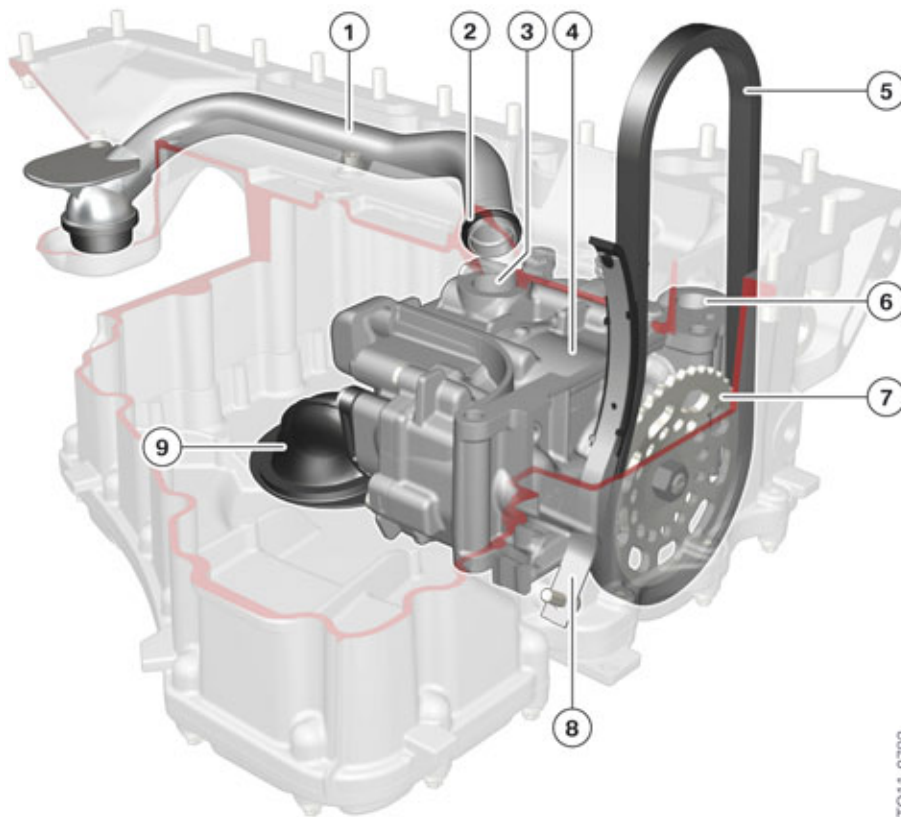

TO11-0782

Oil pump with counterbalance shafts

Index	Explanation
1	Return line
2	O-ring gasket
3	Inlet to rotor pump
4	Pendulum slide cell pump
5	Drive chain for oil pump
6	Oil pump outlet
7	Oil pump sprocket
8	Chain tensioner
9	Intake pipe for pressure pump

S63TU Engine

3. Oil Supply

3.3. Oil filtering and cooling

The S63 top (S63TU) engine uses a full-flow oil filter familiar to the N63 engine. It is bolted into the oil pan from below. The oil filter drain plug is not used. A filter bypass valve is integrated in the oil filter housing.

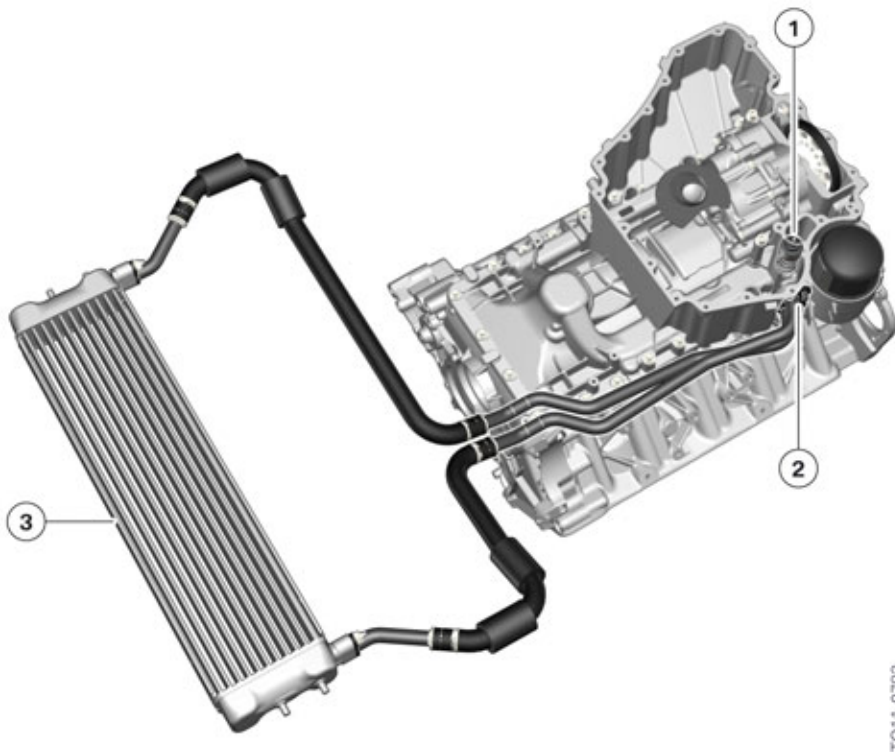

TO11-0783

Oil filter module

Index	Explanation
1	Thermostat
2	Connection for oil cooler
3	Oil cooler

3.3.1. Oil cooling

The S63 top (S63TU) engine has an oil-air heat exchanger for cooling the engine oil which is attached below the cooling module in the front bumper. To allow quick heating of the engine oil, a thermostat is integrated in the oil pan. The thermostat opens from an engine oil temperature of 100 °C and allows the oil to flow through the cooler.

3.3.2. Oil filtering

The S63 top (S63TU) engine has a filter bypass valve which can open a bypass around the filter if the engine oil is cold and thick. This occurs if the pressure difference between before and after the filter exceeds approx. 2.5 bar. The permissible pressure difference has been increased from 2.0 to 2.5 bar

S63TU Engine

3. Oil Supply

in order to protect the lead-free crankshaft and connecting rod bearings. This ensures that the filter is bypassed much less frequently and any dirt particles are filtered out. The filter bypass valve is integrated in the oil filter housing.

3.4. Oil monitoring

3.4.1. Oil level

For monitoring the oil level the known oil condition sensor (QLT) is used. There is no evaluation of the oil condition.

3.5. Oil spray nozzles

In the S63 top (S63TU) engine some components which cannot be reached directly by an oil duct are lubricated and/or cooled by oil spray nozzles.

3.5.1. Piston crown cooling

The oil spray nozzles for piston crown cooling, as used in the S63 top (S63TU) engine. They incorporate a non-return valve to allow them to open and close only from a specific oil pressure. Each cylinder has its own oil spray nozzle, which obtains the correct installation position through its design. In addition to the piston crown cooling, these are also responsible for the lubrication of the piston wrist pins.

S63TU Engine

3. Oil Supply

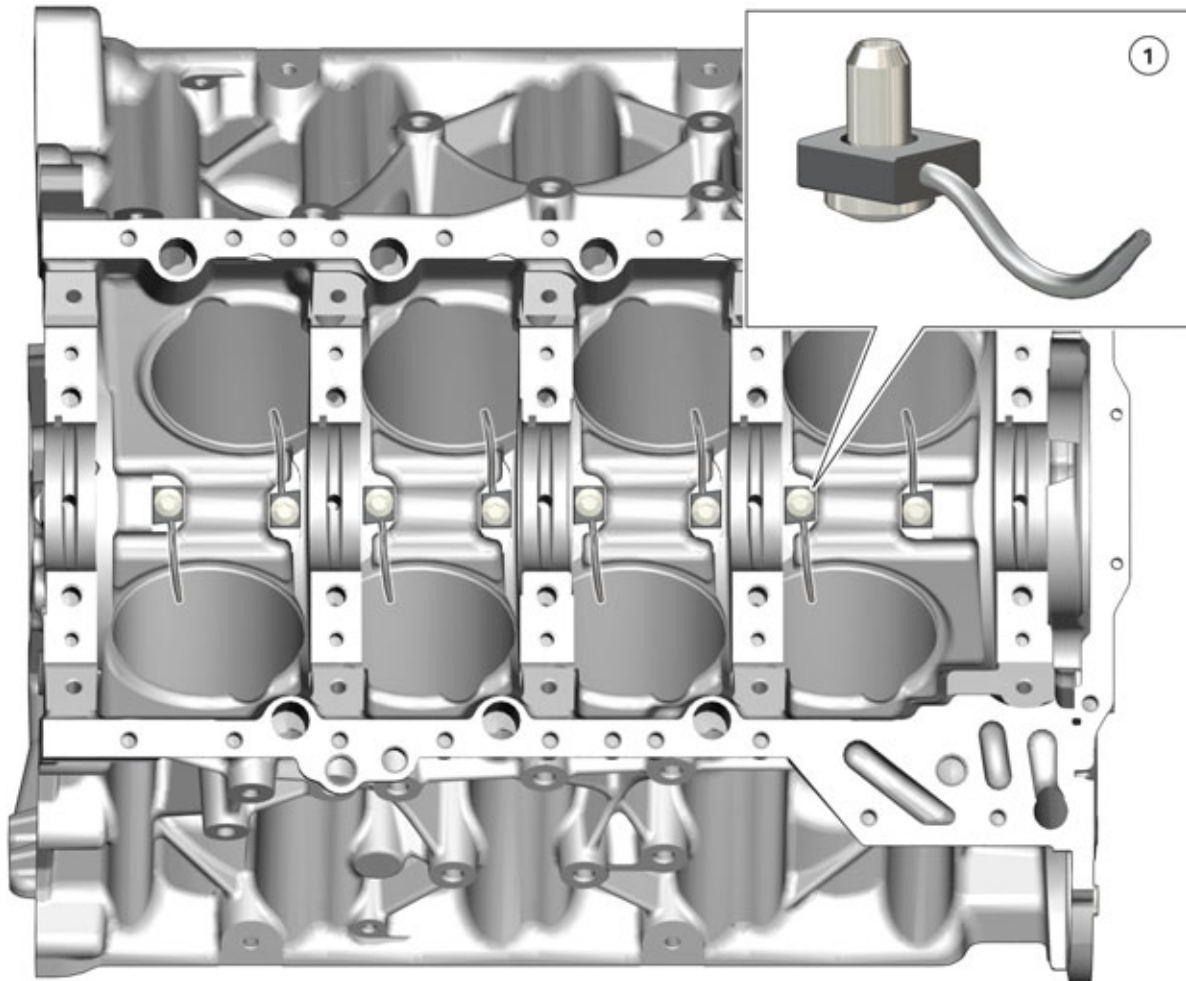

TO11-0785

Oil spray nozzles for the piston crown cooling

Index	Explanation
1	Oil spray nozzle
Opening pressure	2.25 bar – 2.65 bar
Closing pressure	2.0 bar

3.5.2. Chain drive

The chain drive in the S63 top (S63TU) engine is divided into an upper section, the camshaft drive, and a lower section, the oil pump drive.

Camshaft drive

The oil spray nozzles for the lubrication of the timing chains are integrated in the chain tensioner of the specific banks. They spray the oil directly onto the timing chain. The timing chain of the camshaft drive is designed as a toothed roller-type chain.

S63TU Engine

3. Oil Supply

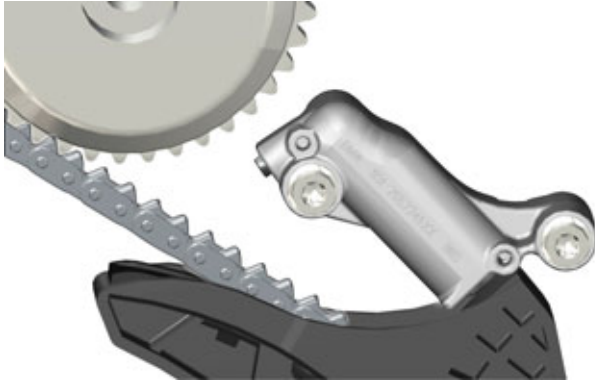

Chain tensioner with oil spray nozzle for the timing chain

Oil pump drive

The oil pump is driven via a roller-type chain by the crankshaft. The roller-type chain is tensioned by a tensioning rail. The secondary drive is lubricated via the oil pan.

S63TU Engine

3. Oil Supply

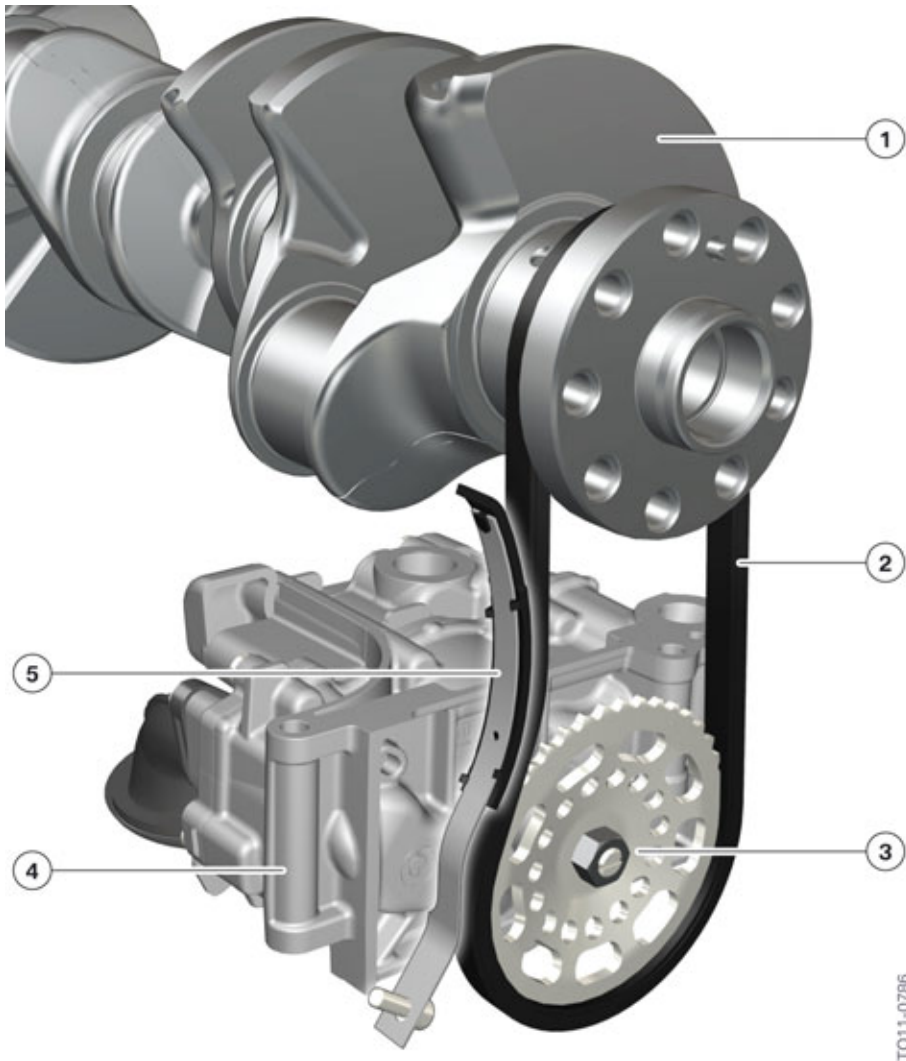

S63 top (S63TU) oil pump drive

Index	Explanation
1	Crankshaft
2	Drive chain for oil pump
3	Gear, oil pump
4	Oil pump
5	Chain tensioner

3.5.3. Camshaft

The oil supply of the chain tensioner, the hydraulic valve clearance compensating elements and the camshaft mounts in the cylinder head is done by a rising pipe from the engine block in the cylinder head. A non-return valve in the cylinder head prevents the oil from draining from the cylinder head.

S63TU Engine

3. Oil Supply

3.5.4. Valvetronic servomotor

The worm gear for adjusting the eccentric shaft is lubricated using the oil spray from the camshaft.

S63TU Engine

4. Cooling System

The cooling system in the S63 top (S63TU) engine is similar to the S63 engine. The engine and charge air cooling both have separate cooling circuits. The DME has now been integrated into the cooling circuit of the charge air cooling the cooling .

4.1. System overview

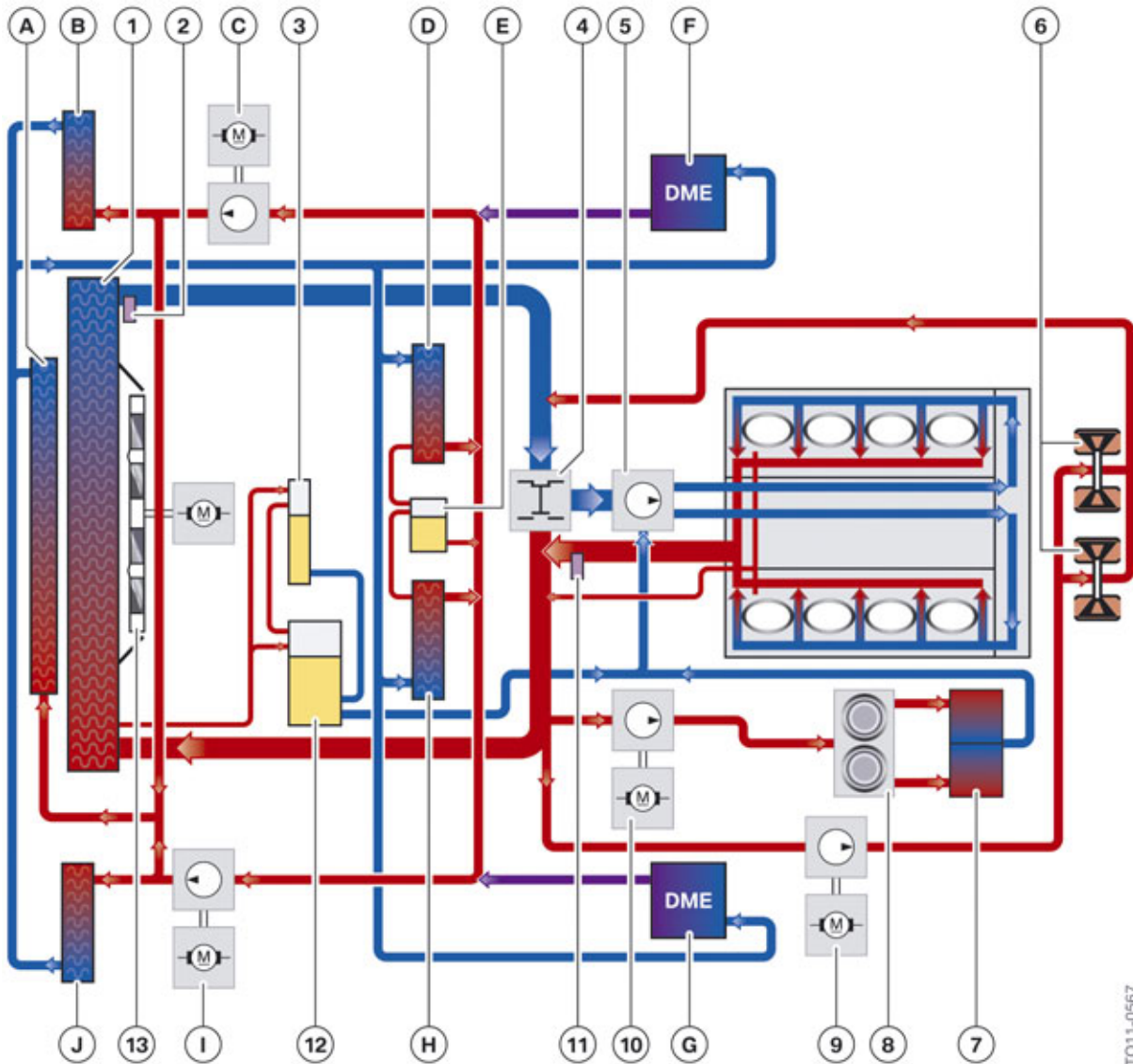

TO11-0567

S63 top (S63TU) complete engine, cooling system

S63TU Engine

4. Cooling System

Index	Explanation
A	Radiator for the charge air cooling
B	Additional radiator for the charge air cooling
C	Electric coolant pump, bank 1
D	Charge air cooler, bank 1
E	Expansion tank, charge air cooling
F	Digital Engine Electronics, bank 1
G	Digital Engine Electronics, bank 2
H	Charge air cooler, bank 2
I	Electric coolant pump, bank 2
J	Additional radiator for the charge air cooling
1	Radiator
2	Heater coil
3	Expansion tank
4	Map thermostat
5	Electric coolant pump
6	Exhaust turbocharger
7	Heat exchanger
8	Coolant valve
9	Electric coolant pump, exhaust turbocharger
10	Electric coolant pump, heating for passenger compartment
11	Coolant temperature sensor
12	Expansion tank
13	Electric fan

4.1.1. Engine cooling circuit

The engine cooling is done by a conventional coolant pump. In the S63 top (S63TU) engine, a higher coolant flow rate is achieved by the modified impeller geometry of the coolant pump. The cylinder head cooling has also been optimized. The cooling module only comes in one variant.

The electric fan has a nominal power of 850 W.

The following graphics show the installation locations and layout of the components.

S63TU Engine

4. Cooling System

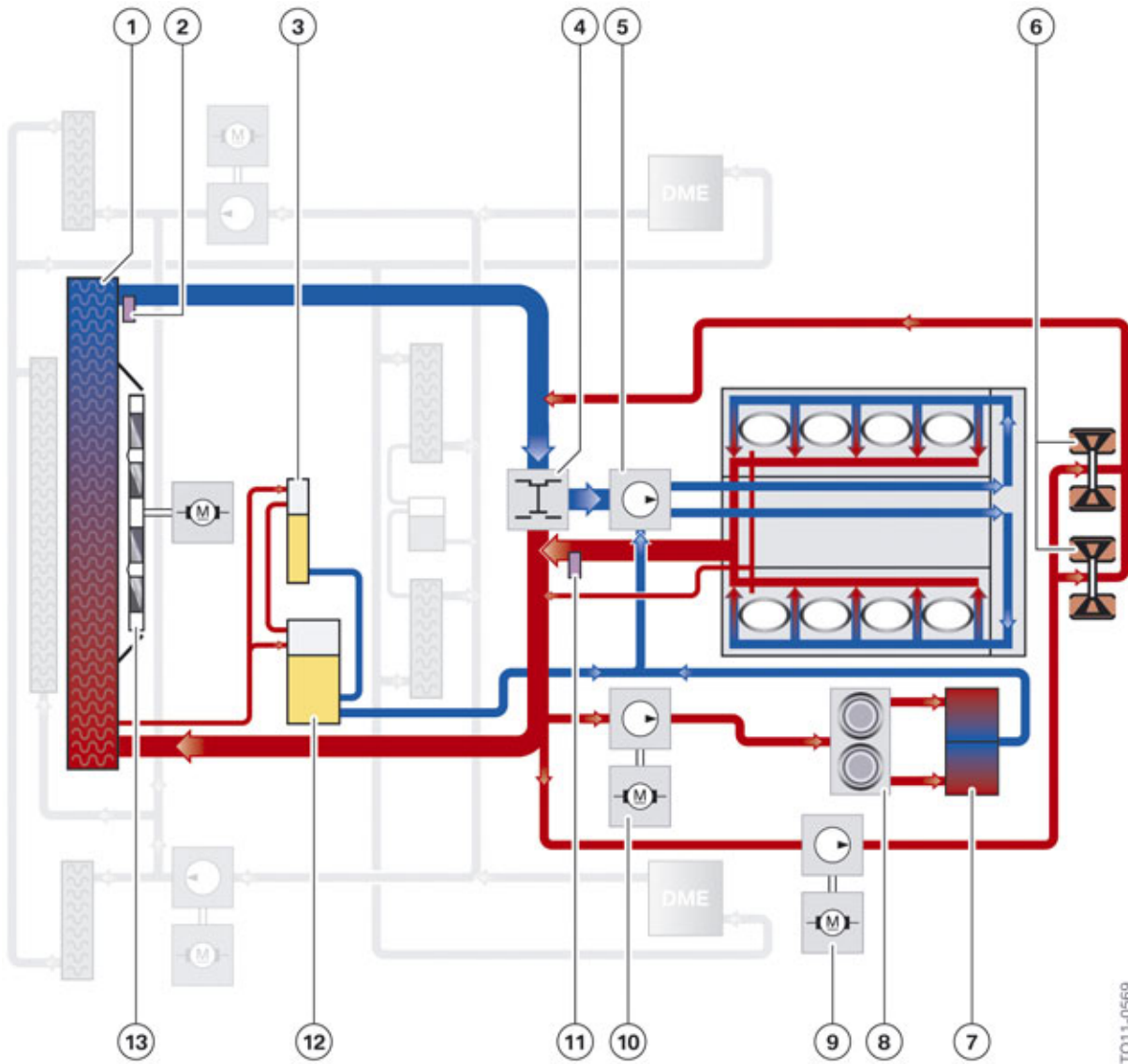

TO11-0569

Cooling system for engine

Index	Explanation
1	Radiator
2	Heater coil
3	Expansion tank
4	Map thermostat
5	Electric coolant pump
6	Exhaust turbocharger
7	Heat exchanger
8	Coolant valve
9	Electric coolant pump, exhaust turbocharger

S63TU Engine

4. Cooling System

Index	Explanation
10	Electric coolant pump, heating for passenger compartment
11	Coolant temperature sensor
12	Expansion tank
13	Electric fan

Components of the cooling circuit for engine without exhaust turbocharger

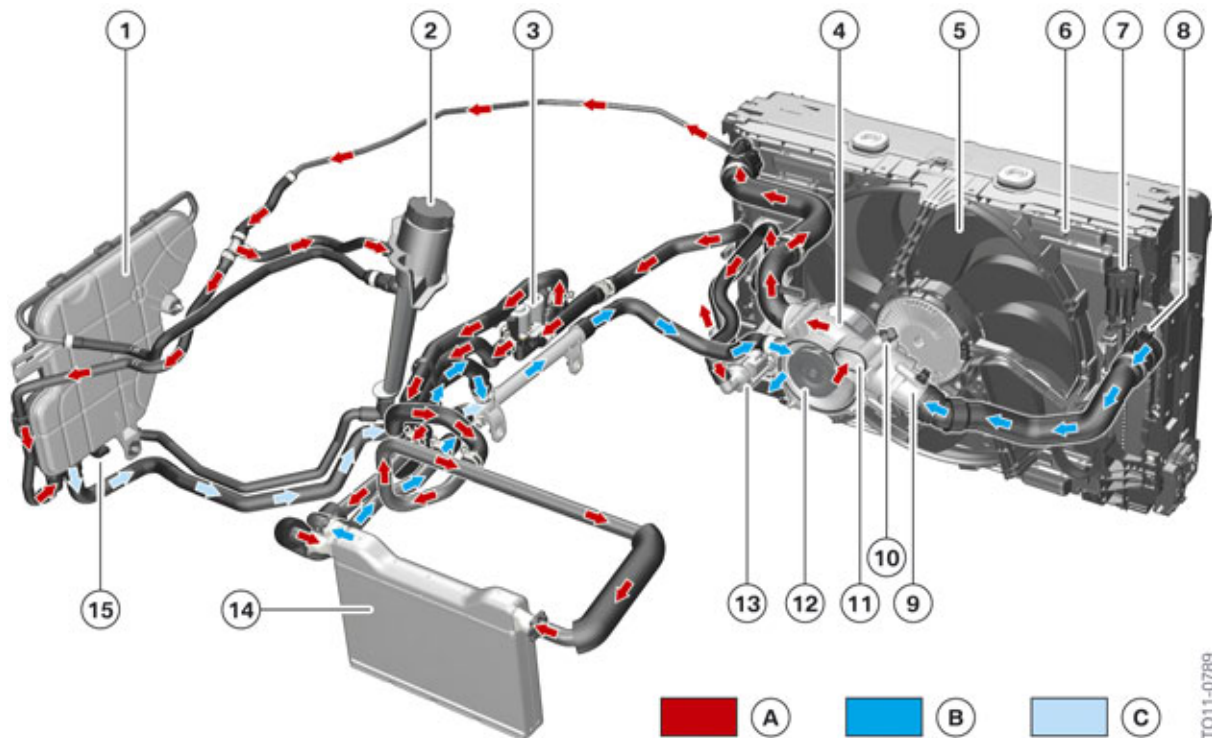

S63 top (S63TU) engine, components for cooling system of engine without exhaust turbocharger

Index	Explanation
1	Expansion tank
2	Coolant filler pipe
3	Coolant valve
4	Coolant pump
5	Electric fan
6	Radiator
7	Plug connection for electric fan
8	Coolant temperature sensor at radiator outlet
9	Map thermostat
10	Coolant temperature sensor at engine outlet

S63TU Engine

4. Cooling System

Index	Explanation
11	Inlet for hot coolant from engine in coolant pump
12	Inlet for cold coolant in the engine
13	Electric auxiliary coolant pump for passenger compartment heating
14	Heat exchanger
15	Coolant level sensor

Components of exhaust turbocharger cooling circuit

The conventional coolant pump is driven by a belt and cannot be used for cooling the exhaust turbocharger after the engine has shut down. For this reason there is an electric coolant pump, which works at a power of 20 W. This is done by a separate cooling circuit. This circuit can also be activated during engine operation, the electric coolant pump can be switched on taking into account the following factors:

- Coolant temperature at engine outlet
- Engine oil temperature
- Injected fuel quantity.

The heat input into the engine is calculated using these values. The after-run of the electric coolant pump can last up to 30 minutes. To improve the cooling effect, the electric fan is activated and can run for up to a max. of 11 minutes.

S63TU Engine

4. Cooling System

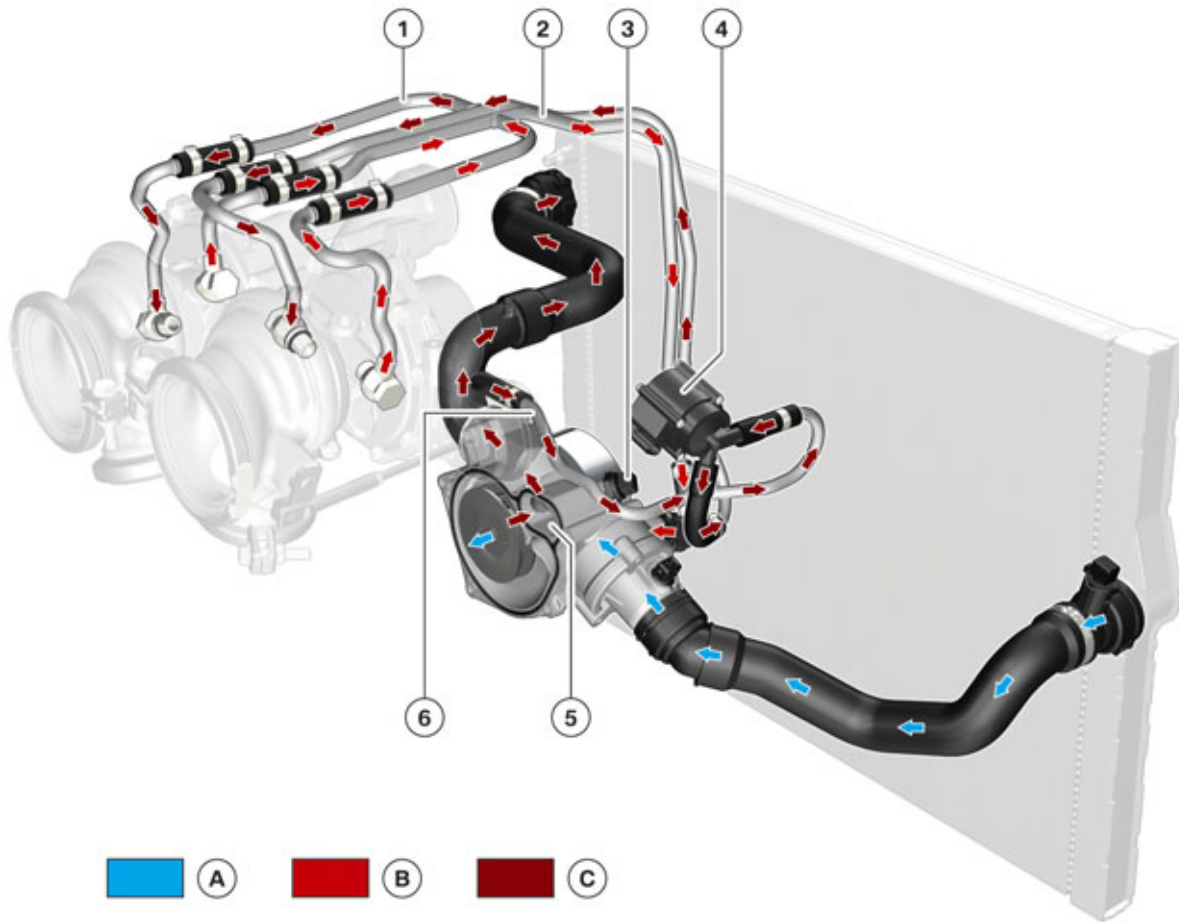

Cooling circuit of the exhaust turbocharger with electrical auxiliary water pump

Index	Explanation
A	Cooled coolant
B	Return of hot coolant from exhaust turbocharger
C	Hot coolant from engine
1	Supply line to the exhaust turbochargers from the electric coolant pump
2	Return line from exhaust turbochargers to conventional coolant pump
3	Electric coolant pump
4	Coolant temperature sensor at engine outlet
5	Return of hot coolant from engine to radiator
6	Intake pipe of electric coolant pump

TO11-1176

S63TU Engine

4. Cooling System

4.1.2. Charge air cooler and DME cooling circuit

To guarantee sufficient cooling of the charge air, the coolant-air heat exchangers have increased in size for the S63TU engine in comparison to the S63 engine. These are supplied with coolant by an independent cooling system with two (50 W) electric coolant pumps. The cooling circuit for the charge air cooling is combined with the Digital Engine Electronics (DME) and contain a radiator and two auxiliary coolers in the front bumper on the left and right sides.

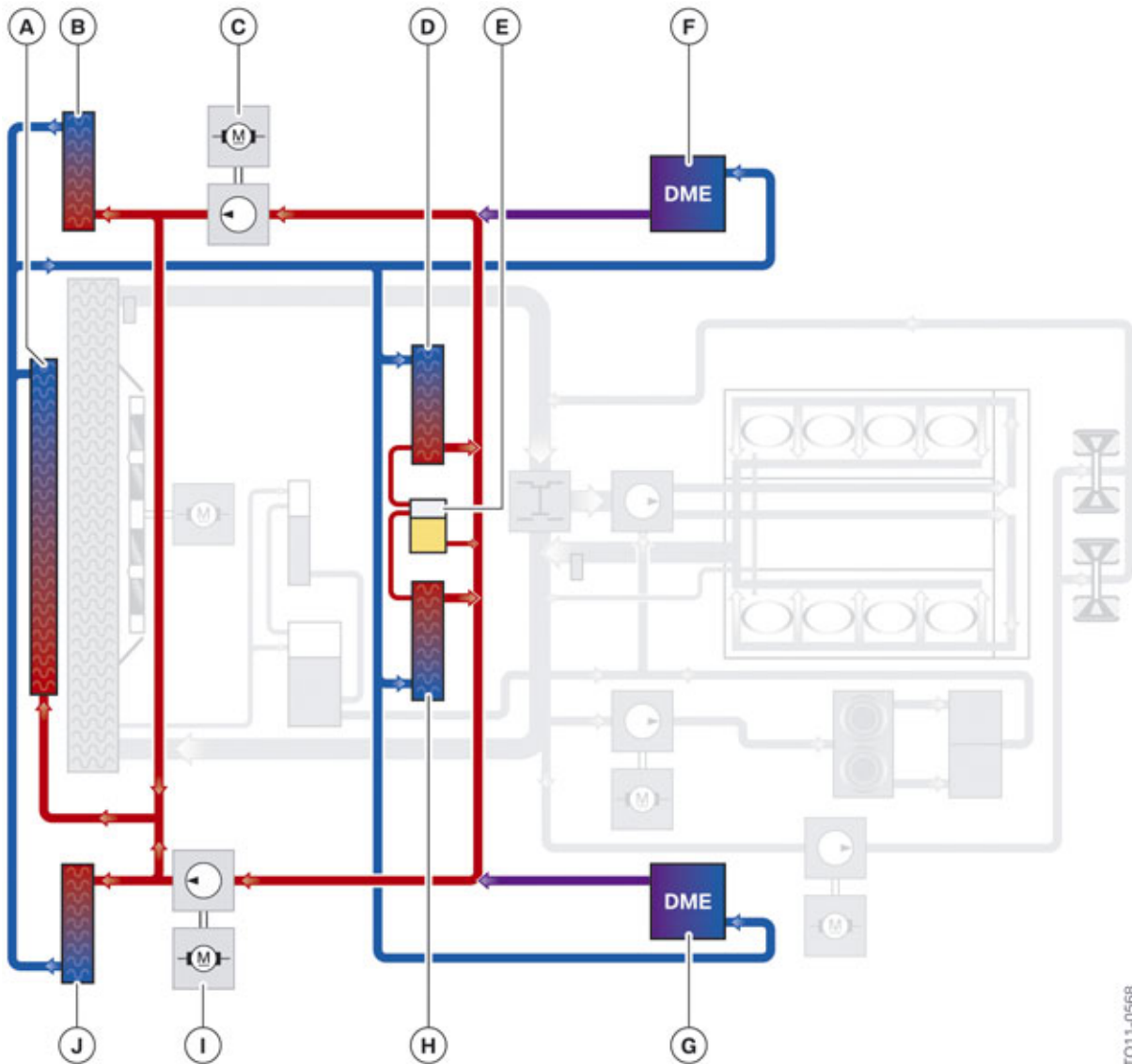

TO11-0568

Charge air/DME cooling

S63TU Engine

4. Cooling System

Index	Explanation
A	Radiator for the charge air cooling
B	Additional radiator for the charge air cooling
C	Electric coolant pump, bank 1
D	Charge air cooler, bank 1
E	Expansion tank for the charge air cooling
F	DME, bank 1
G	DME, bank 2
H	Charge air cooler, bank 2
I	Electric coolant pump, bank 2
J	Additional radiator for the charge air cooling

Components

Both 50 W pumps have a self-diagnosis and dry-run protection. If the pump speed increases by 15 rpms over a pre determined period, the auxiliary water pumps are switched off and an fault code is stored in the DME. The expansion tank does not have a coolant level switch and does not automatically detect when the fluid level is too low. In the case of a lack of fluid in the cooling circuit of the charge air cooler and DME, a warning light in the instrument panel signals either too high an intake air temperature with a parallel reduction in power or insufficient DME cooling. A Check Control message also appears.

S63TU Engine

4. Cooling System

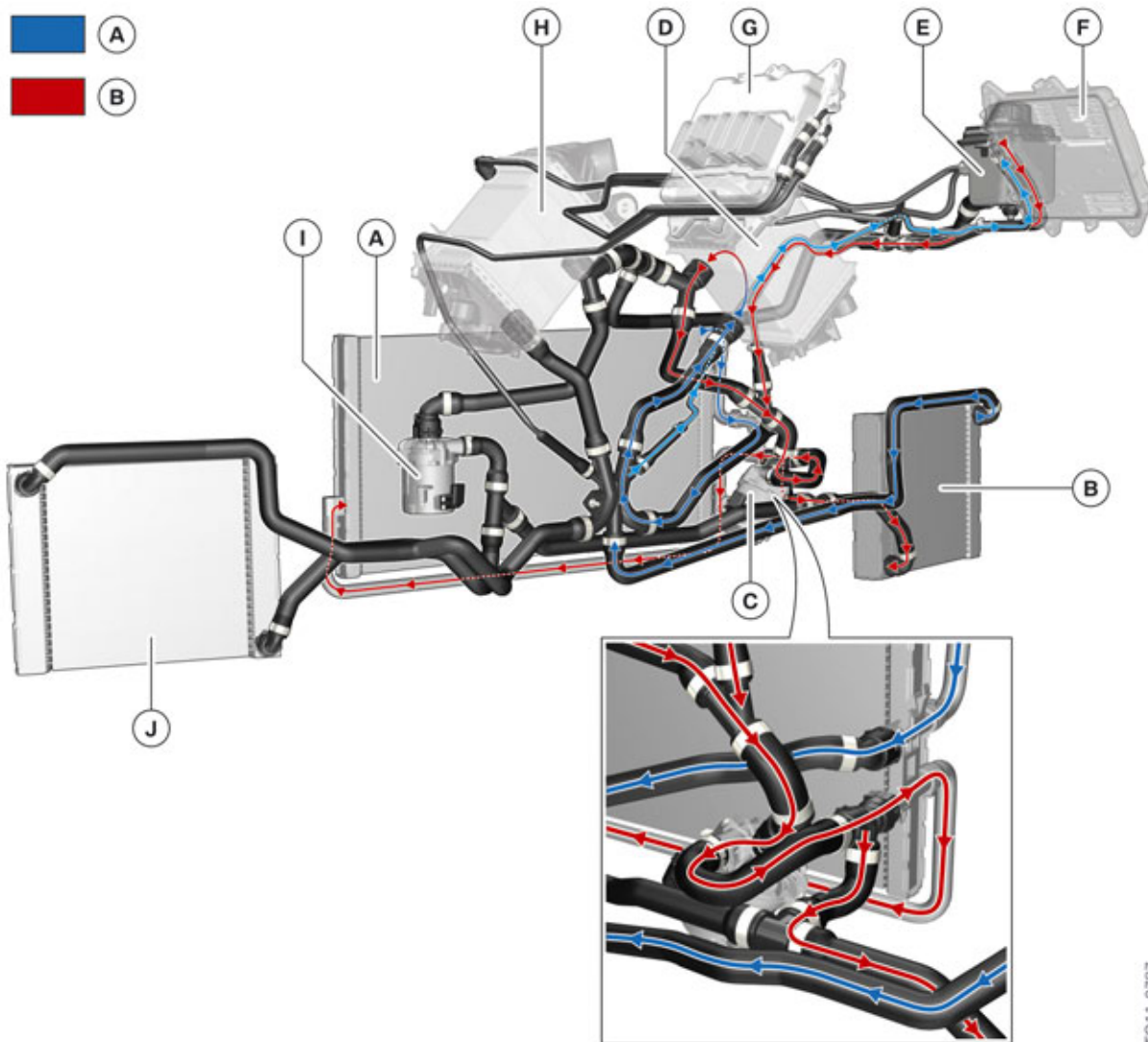

TO11-0787

Cooling circuit for charge air with DME

Index	Explanation
A	Radiator for the charge air cooling
B	Auxiliary cooler for the charge air cooling (right side)
C	Electric coolant pump, bank 1
D	Charge air cooler, bank 1
E	Expansion tank for the charge air cooling
F	DME, bank 1
G	DME, bank 2
H	Charge air cooler, bank 2
I	Electric coolant pump, bank 2
J	Auxiliary cooler for the charge air cooling (left side)

S63TU Engine

4. Cooling System

4.2. Heat management

The S63 top (S63TU) engine has the same heat management function in the Digital Engine Electronics (DME) as in the N55 engine. This includes independent control of the electric cooling components of electric fan, map thermostat and coolant pumps.

4.2.1. Coolant pump

The S63 top (S63TU) engine has a total of four electric coolant pumps in addition to the mechanical pumps. One for the passenger compartment heating, another for the cooling of the exhaust turbocharger and two additional electric coolant pumps for cooling the charge air cooler and DME.



If the coolant pump is removed and then to be reused, it is important to ensure that it is set down still filled with coolant. Drying out may cause the bearings to stick. The reason for this is that the coolant pump may not run, which in turn may result in damage to the engine.

Before installing, turn the pump impeller manually to ensure that it moves freely.

4.2.2. Map thermostat

The S63 top (S63TU) engine is fitted with a map thermostat which has the following technical data in non-electrically controlled mode:

- Opening start at 105 °C
- Complete opening at 120 °C.

In addition, an electric heater in the map thermostat can be used to make the thermostat open at a lower coolant temperature.

S63TU Engine

5. Air Intake/Exhaust Emission System

The air intake and exhaust emission systems are in principle comparable with those in the S63 engine. The list below shows the most important changes to the air intake and exhaust emission systems:

- Flow-optimized air intake system
- Hot film air mass meter 7
- Adaptation of the air intake system with regard to the Valvetronic servomotor
- Enlarged air-coolant heat exchanger for increasing the cooling power and reducing the pressure losses
- Optimized exhaust manifold.

5.1. Overview

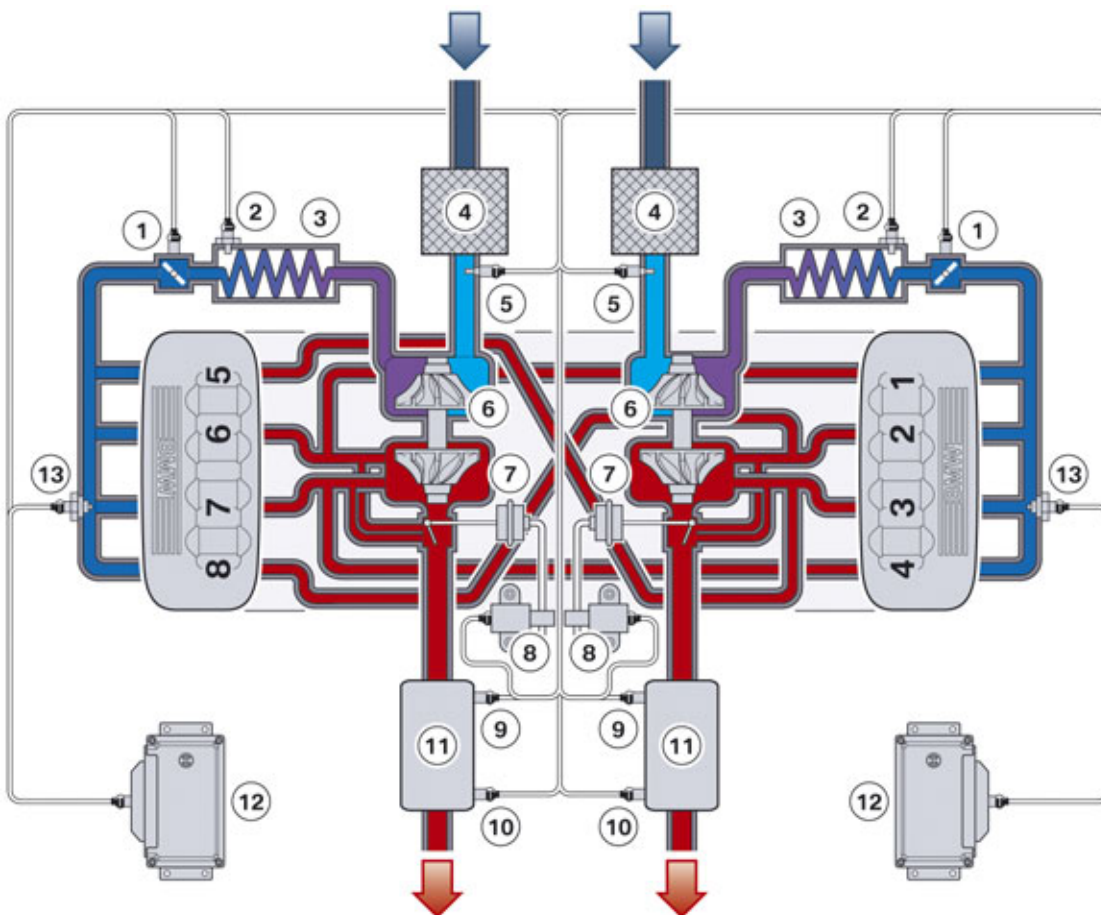

Intake air and exhaust emission system

TO11-0570

S63TU Engine

5. Air Intake/Exhaust Emission System

Index	Explanation
1	Throttle valve
2	Charge-air temperature sensor and pressure sensor
3	Charge air cooler
4	Intake silencer
5	Hot-film air mass meter
6	Exhaust turbocharger
7	Wastegate valve
8	Electropneumatic pressure converter
9	Oxygen sensor before catalytic converter (control sensor)
10	Oxygen sensor after catalytic converter (monitoring sensor)
11	Catalytic converter
12	Digital Engine Electronics (DME)
13	Intake manifold pressure sensor

S63TU Engine

5. Air Intake/Exhaust Emission System

5.2. Air intake system

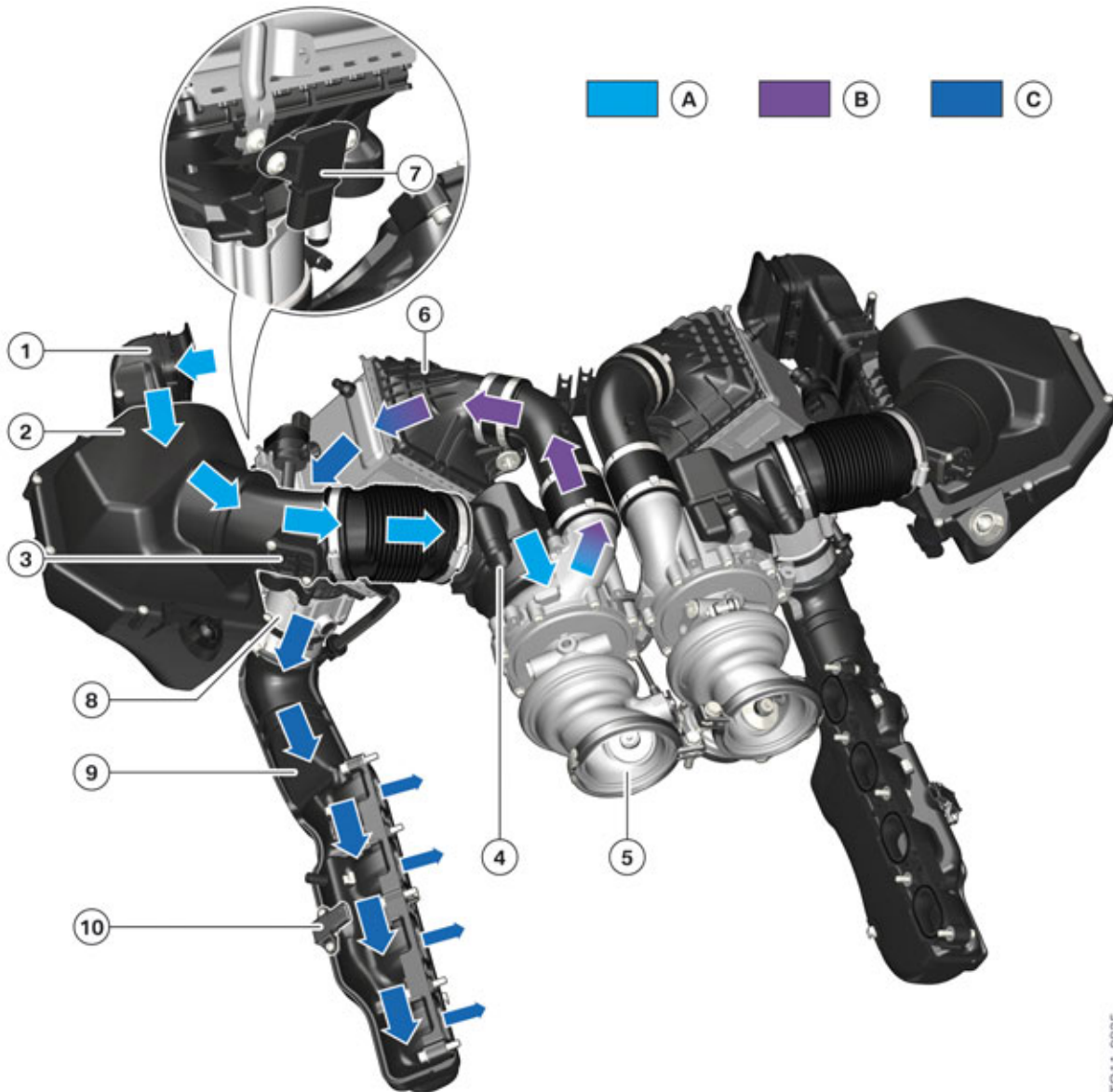

TO11-0825

Air intake system

Index	Explanation
A	Intake air
B	Compressed, hot charge air
C	Cooled charge air
1	Intake snorkel
2	Intake silencer
3	Hot film air mass meter

S63TU Engine

5. Air Intake/Exhaust Emission System

Index	Explanation
4	Connection for crankcase ventilation for clean air pipe
5	Exhaust turbocharger
6	Charge air cooler
7	Charging pressure sensor
8	Throttle valve
9	Intake manifold
10	Charge air temperature and intake-manifold pressure sensor

5.2.1. Intake silencer

The S63 top (S63TU) engine has its own intake silencer for each bank. These also hold the hot film air mass meters.

5.2.2. Hot film air mass meter

The S63 top (S63TU) engine is fitted with the hot film air mass meter 7, which is very similar to the one in the N20 engine.



Failure or disconnection of the hot film air mass meter does not immediately result in emergency engine operation. However, impaired mixture preparation and therefore increased emission levels are possible, which is why the emissions warning lamp lights up.

5.2.3. Intake manifold

The volume of the air intake system has been optimized and it has a flow-optimized connection for the throttle body. In comparison to previous turbocharged BMW engines the S63TU does not use a blow-off valve. The use of Valvetronic and special tuning rendered it unnecessary.

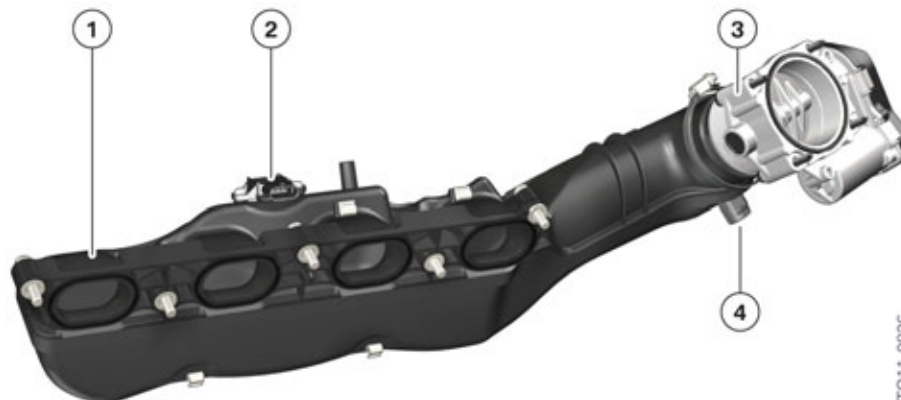

Intake system with throttle valve

TO11-0626

S63TU Engine

5. Air Intake/Exhaust Emission System

Index	Explanation
1	Intake manifold
2	Air temperature and intake-manifold pressure sensor
3	Throttle valve
4	Connection from tank vent valve

5.3. Exhaust turbocharger

The S63 top (S63TU) engine features two exhaust turbochargers with TwinScroll technology. It includes at the turbine inlet two separate ducts in which the exhaust gas is routed from two cylinders to the turbine vanes. The turbines and compressor have been slightly redesigned, with this design the exhaust turbocharger is not sensitive to pump. With these upgrades and the use of Valvetronic along with special programming the blow-off valve is no longer necessary thus they are not installed.

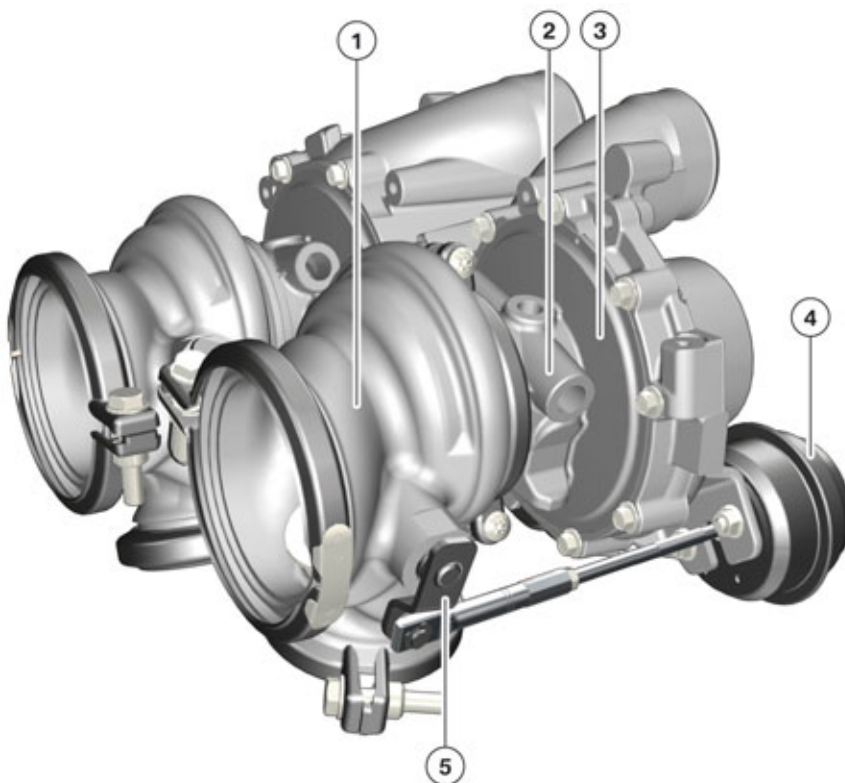

TO11-0827

S63 top (S63TU) TwinScroll exhaust turbocharger

S63TU Engine

5. Air Intake/Exhaust Emission System

Index	Explanation
1	Turbine
2	Bearing seat
3	Compressor
4	Vacuum unit
5	Wastegate valve



Proper positioning of exhaust turbocharger during installation is necessary.

The S63TU turbochargers require a special tool to align them in their proper installation location. Always follow proper repair instructions.



Turbocharger alignment tool #2 249 171

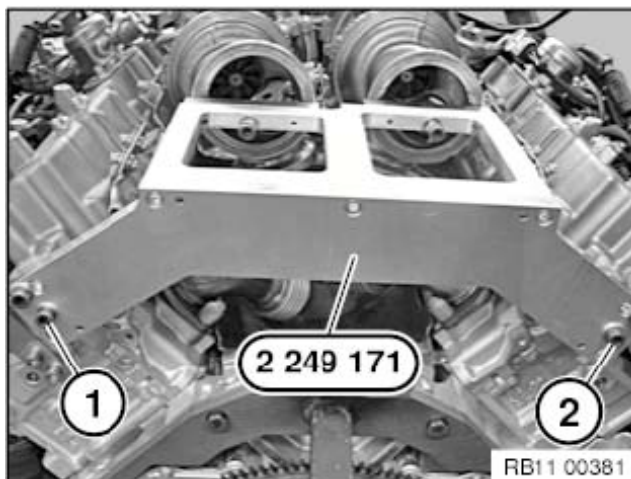

Turbocharger alignment tool #22 49 171

S63TU Engine

5. Air Intake/Exhaust Emission System

5.3.1. Function

The designation TwinScroll denotes an exhaust turbocharger with a twin-scroll turbine housing.

The S63TU is fitted with 2 segment four into two exhaust manifold that connects both cylinder banks in an ideal configuration where the exhaust gas pulses from cylinders 1/6 and 4/7 are fed to the exhaust turbocharger installed over cylinder bank 5/8 (L) and the exhaust gas from cylinders 2/8 and 3/5 is fed to the exhaust turbocharger installed over cylinder bank 1-4 (R), independently from each other. In this way, so-called pulse supercharging is used to greater effect.

This creates a spacing of 360° of crankshaft angle between the two exhaust bank cycles within the exhaust flute that feeds each twin scroll turbocharger impeller. The effective utilization of the exhaust gas energy delivers optimum de-throttling and ideal response characteristics.

More Information on the functioning principle of the TwinScroll exhaust turbocharger can be found in the "N20 Engine training material" available on TIS and ICP.

5.4. Exhaust emission system

5.4.1. Exhaust manifold

The S63TU exhaust manifold has been flow-optimized in comparison to the S63 engine. The flow-optimized manifold is a four-into-two type (two overlapping), which is necessary for the special function of the TwinScroll turbocharger. The double wall design of the previous S63 exhaust manifold has been discontinued and replaced with an open pipe design so that the generated heat can now escape upwards through the ventilated heat shields. There are also corrugated elements mounted at the exhaust manifolds in order to balance the thermomechanical movements in the individual sections of the exhaust manifold.

S63TU Engine

5. Air Intake/Exhaust Emission System

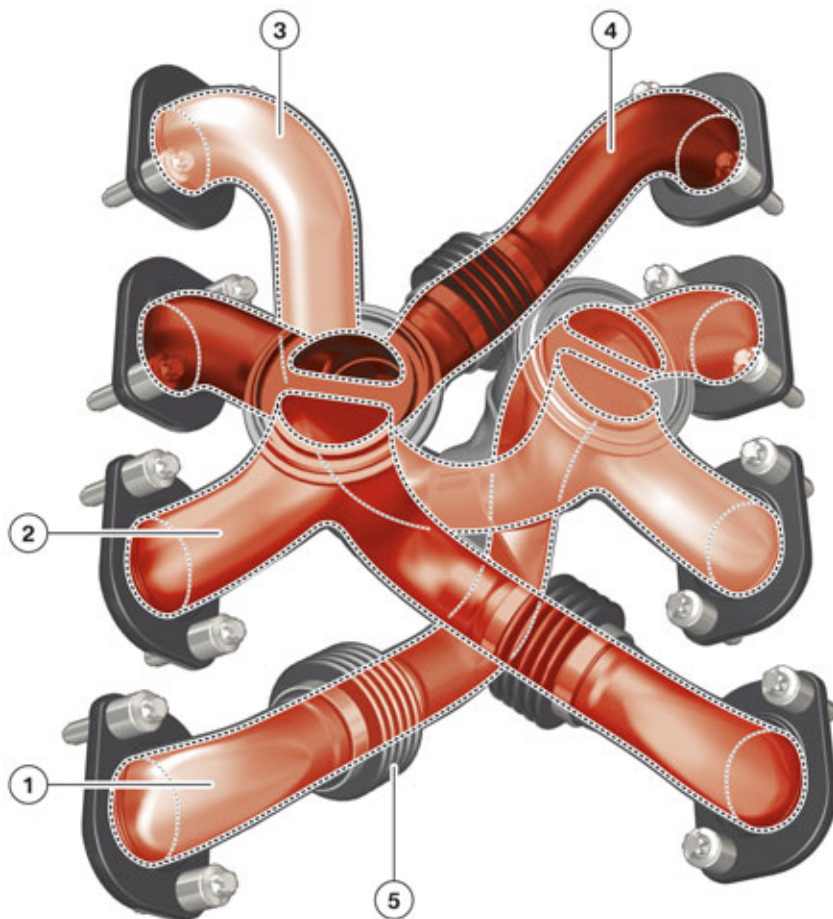

TO11-0828

S63 top (S63TU) exhaust manifold with exhaust turbocharger in driving direction, 1st cylinder, top right

Index	Explanation
1	Exhaust manifold 1 combines cylinders 2 and 8 to feed the right front turbo/scroll
2	Exhaust manifold 2 combines cylinders 4 and 7 to feed the left rear turbo/scroll
3	Exhaust manifold 1 combines cylinders 3 and 5 to feed the right rear turbo/scroll
4	Exhaust manifold 2 combines cylinders 1 and 6 to feed the left front turbo/scroll
5	Corrugated elements

S63TU Engine

5. Air Intake/Exhaust Emission System



The S63TU cross-bank exhaust manifold also requires a special tools to align it into its proper installation location. Always follow proper repair instructions.



For locating cross-bank exhaust manifold during installation Tool # 2 249 161

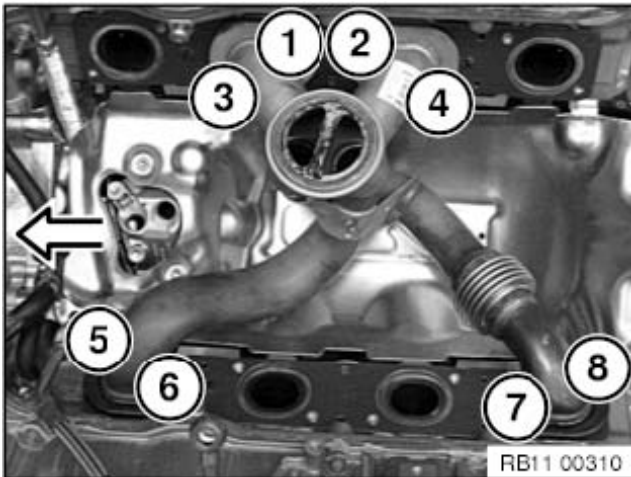

Please refer to Repair Instructions for F10 S63TU, job item 18 40 010.

5.4.2. Catalytic converter

The S63 top (S63TU) engine features one catalytic converter per bank, which is double-walled. The catalytic converters no longer have any decoupling elements.

S63TU Engine

5. Air Intake/Exhaust Emission System

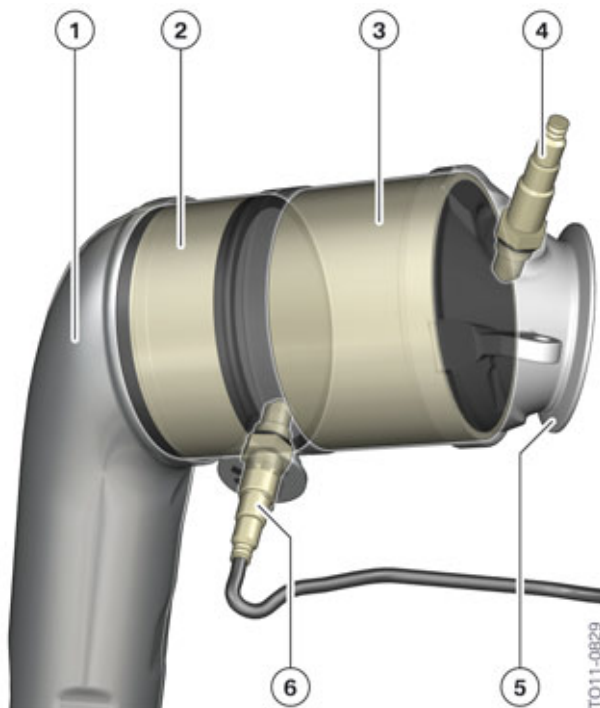

Sectional view of the catalytic converter

Index	Explanation
1	Connection to exhaust system
2	Ceramic monolith 2
3	Ceramic monolith 1
4	Control sensor
5	Connection to turbine
6	Monitoring sensor

Oxygen sensors

Bosch oxygen sensors are used:

- Control (pre) sensor: LSU ADV
- Monitoring (post) sensor: LSF4.2.

The control sensor is located ahead of the primary catalytic converter, as close as possible to the turbine outlet. Its position has been chosen so that all the cylinders can be recorded separately. The monitoring sensor is positioned between the first and second ceramic monoliths.

S63TU Engine

6. Vacuum System

The vacuum system of the S63 top (S63TU) engine differs from the S63 engine. The vacuum reservoir and the pressure converter have a new EBO and the vacuum lines have been adapted.

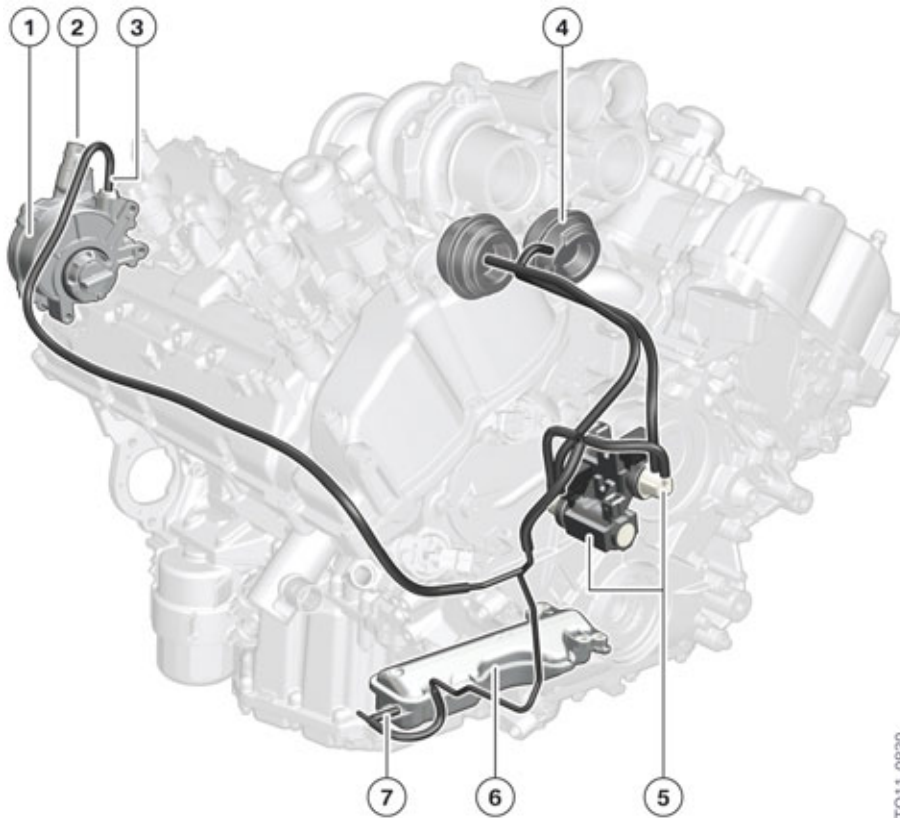

TO11-0630

S63 top (S63TU) vacuum system

Index	Explanation
1	Vacuum pump
2	Connection, brake servo
3	Connection for secondary consumer
4	Vacuum units for wastegate valves
5	Electropneumatic pressure converter for wastegate valves
6	Vacuum reservoir
7	Connection for vacuum line to the electric switch value for vacuum units of exhaust flaps

The two stage vacuum pump is used so that the majority of the generated vacuum is made available to the brake servo. The vacuum reservoir is now no longer positioned in the V area of the engine, but is attached at the lower side of the oil pan.

S63TU Engine

7. Fuel Preparation

The S63 top (S63TU) engine makes use of high-pressure injection, which was introduced in the N55 engine. It differs from high-precision injection (HPI) in that it uses solenoid valve injectors with multi-hole nozzles.

7.1. Overview

The following overview shows the fuel preparation of the S63 top (S63TU) engine. It corresponds to the systems with direct fuel injection in other BMW models.

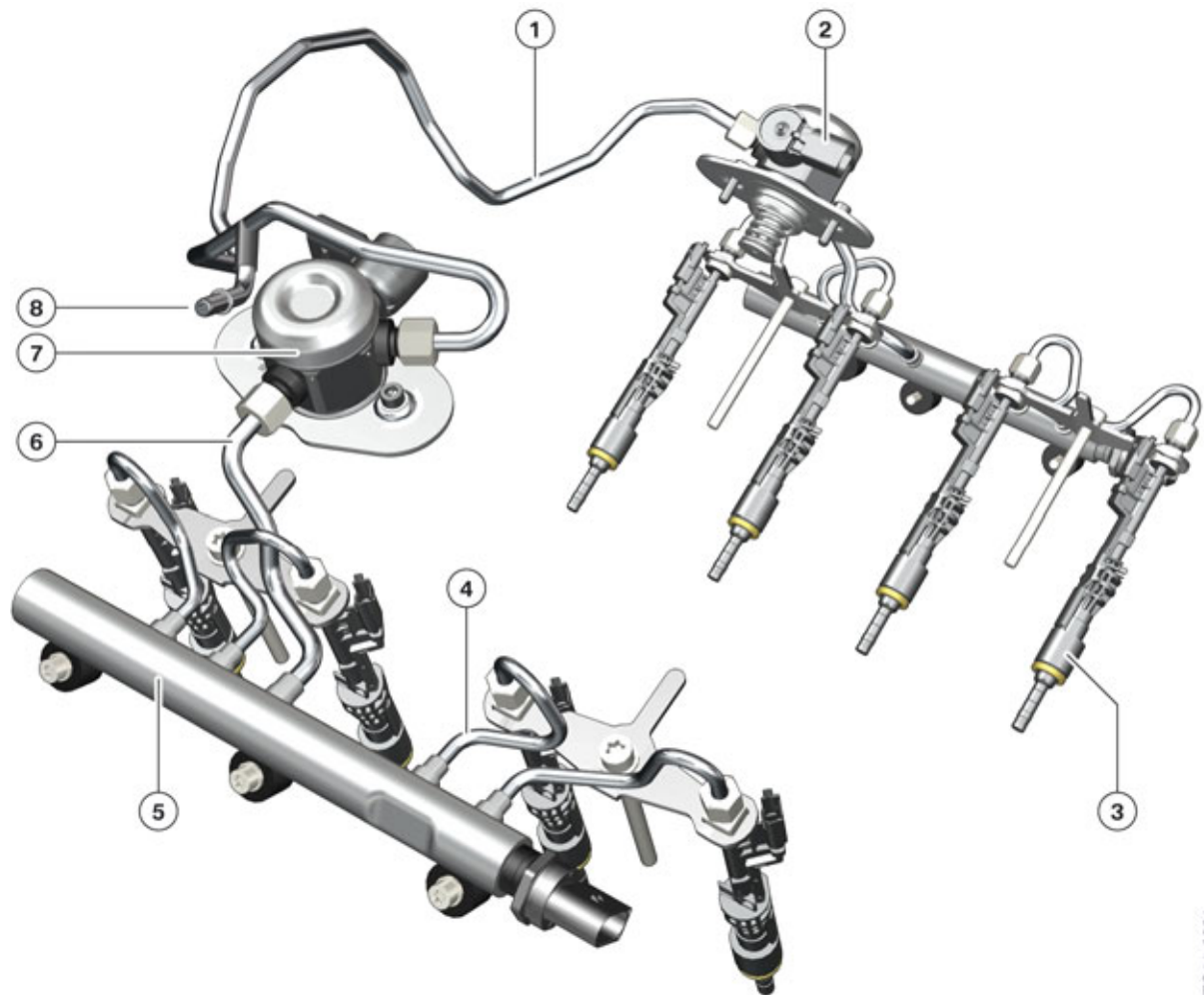

TO11-0831

Fuel preparation

Index	Explanation
1	Fuel hose
2	Fuel quantity control valve
3	Injector
4	High-pressure line, rail - injector

S63TU Engine

7. Fuel Preparation

Index	Explanation
5	Rail
6	High-pressure line, high-pressure pump - rail
7	High-pressure pump
8	Fuel supply line

Bosch high-pressure fuel injectors with the designation HDEV5.2 are used. The high pressure pump is already known from the 4, 8 and 12-cylinder engines. An innovation in the S63 top (S63TU) engine is the fact that the high-pressure lines from rail to injector are now no longer threaded at the rail end, but welded similar to the N20.



Do not open the fuel system if the coolant temperature is above 40°C/104°F. The residual pressure in the high pressure fuel system could cause bodily injury.

It is essential to observe the utmost cleanliness when working on the high pressure fuel system and to follow the proper working procedures described in the repair instructions. Even minute soiling or damage at the thread connections of the high pressure lines could cause leaks.

When working on the fuel system of the S63TU engine, it is important to ensure that the ignition coils are not wet with fuel. The resistance of the silicone material is greatly reduced by sustained contact with fuel. This could result in arcing at the top of the spark plug and misfiring.

- Before making any modifications to the fuel system, always remove the ignition coils and protect the spark plug shaft against the ingress of fuel by covering them with a cloth
- Before reinstalling the solenoid valve injectors, remove the ignition coils and ensure that greatest possible cleanliness is maintained.
- Ignition coils heavily saturated with fuel must be replaced.

7.2. Fuel pump control

The fuel is delivered from the fuel tank through the electric fuel pump via the feed line at a primary pressure of 5 bar to the high pressure pump. The primary pressure is monitored via the low-pressure sensor. The fuel is sent from the electric fuel pump as required. In the event of malfunction of the sensor the electric fuel pump continues to operate at 100% delivery rate with terminal 15 ON.

7.3. High-pressure pump

A Bosch high pressure pump is used. This is a single-plunger pump which is driven from the exhaust camshaft via a triple cam. So that sufficient fuel pressure is guaranteed in all operating conditions of the engine, a high-pressure pump is used in the S63 top (S63TU) engine for each bank.

For further information on the high-pressure pump, please refer to the “N74 Engine” Training material available on TIS and ICP.

S63TU Engine

7. Fuel Preparation

7.4. Injectors

The Bosch HDEV5.2 solenoid valve injector with an inward-opening multi-hole valve is used. The HDEV5.2 is configured for a system pressure of up to 200 bar.

These injectors are already in use in the N55 and N20 engine.

For further information on injector activation, refer to the section entitled Engine Management System.



The housing of the solenoid valve injectors can only withstand a certain tensile force and a certain torque. It is essential when removing and installing the injectors to use special tools and follow the specific procedure set out in the repair instructions, as otherwise the injectors will be damaged.

S63TU Engine

8. Fuel Supply

The fuel supply is vehicle-specific. The difference to the F10 production vehicles is the increase of the fuel tank capacity by 10 liters (2.64 gallons) to a total of 80 liters (21 gallons). The electric fuel pump is adapted to the engine at an increased delivery rate.

S63TU Engine

9. Engine Management System

9.1. Overview

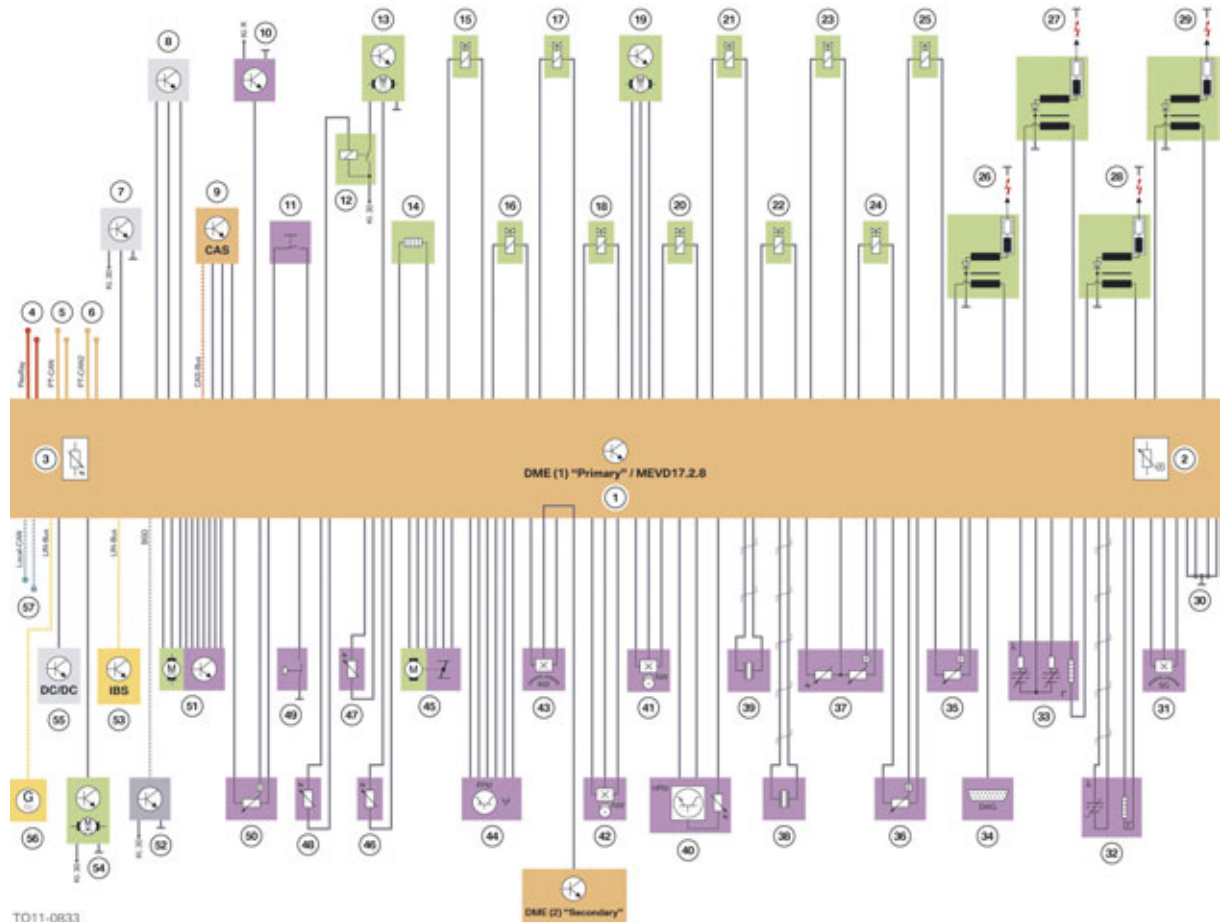

TO11-0833

DME I wiring diagram MEVD17.2.8

Index	Explanation
1	Engine electronics (DME I) Valvetronic direct injection MEVD17.2.8
2	Ambient pressure sensor
3	Temperature sensor
4	FlexRay
5	PT-CAN
6	PT-CAN2
7	Tank leak diagnosis
8	Zero-gear sensor (only for manual gearbox)
9	Car Access System (CAS)
10	Clutch module
11	Sport button
12	Relay for electric fan

S63TU Engine

9. Engine Management System

Index	Explanation
13	Electric fan
14	Map thermostat
15	Fuel tank non-return valve
16	Tank vent valve
17	VANOS solenoid valve, intake camshaft
18	VANOS solenoid valve, exhaust camshaft
19	Electric coolant pump, exhaust turbocharger
20	Pressure converter (EPDW) wastegate
21	Quantity control valve
22–25	Injector
26–29	Ignition coil
30	Ground
31	Speed sensor, manual gearbox
32	Post Oxygen sensor LSF4.2
33	Pre Oxygen sensor (LSU) ADV
34	Speed signal
35	Charging pressure sensor before throttle valve
36	Rail pressure sensor
37	Charge air temperature and intake-manifold pressure sensor after throttle valve
38	Knock sensor 1–2
39	Knock sensor 3–4
40	Hot film air mass meter (HFM) 7
41	Camshaft sensor, intake camshaft
42	Camshaft sensor, exhaust camshaft
43	Crankshaft sensor, signal is forwarded to DME II
44	Accelerator pedal module
45	Throttle valve
46	Engine temperature
47	Temperature, cooler outlet
48	Oil temperature
49	Oil pressure switch
50	Brake vacuum sensor (manual gearbox only)
51	Valvetronic servomotor
52	Oil level sensor

S63TU Engine

9. Engine Management System

Index	Explanation
53	Intelligent battery sensor (IBS)
54	Electric coolant pump, charge air cooler and Digital Engine Electronics (DME I)
55	DC/DC converter
56	Alternator
57	Local Controller Area Network between DME I and DME II

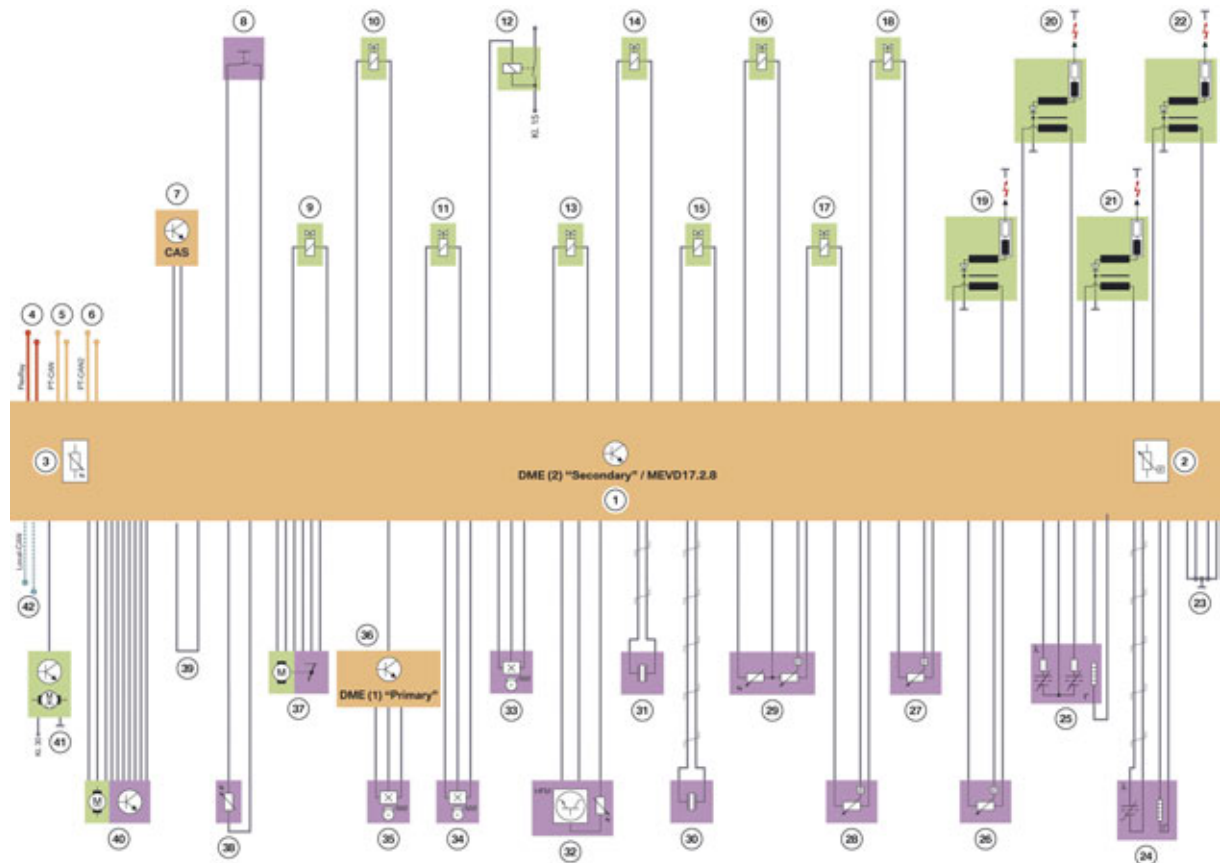

TD11-0624

DME II wiring diagram MEVD17.2.8

Index	Explanation
1	Engine electronics (DME II) Valvetronic direct injection MEVD17.2.8
2	Ambient pressure sensor
3	Temperature sensor
4	FlexRay
5	PT-CAN
6	PT-CAN2
7	Car Access System (CAS)

S63TU Engine

9. Engine Management System

Index	Explanation
8	Servotronic button
9	Tank vent valve
10	VANOS solenoid valve, intake camshaft
11	VANOS solenoid valve, exhaust camshaft
12	Relay, transmission oil pump (manual gearbox only)
13	Pressure converter (EPDW)
14	Quantity control valve
15–18	Injector
19–22	Ignition coil
23	Ground
24	Post Oxygen sensor LSF4.2
25	Pre Oxygen sensor (LSU) ADV
26	Fuel low-pressure sensor
27	Charging pressure sensor before throttle valve
28	Rail pressure sensor
29	Charge air temperature and intake-manifold pressure sensor after throttle valve
30	Knock sensor 5–6
31	Knock sensor 7–8
32	Hot film air mass meter (HFM) 7
33	Camshaft sensor, intake camshaft
34	Camshaft sensor, exhaust camshaft
35	Crankshaft sensor (DME I)
36	Digital Engine Electronics (DME I)
37	Throttle valve
38	Transmission oil temperature (manual gearbox only)
39	Encoding wire
40	Valvetronic servomotor
41	Electric coolant pump, charge air cooler and Digital Engine Electronics (DME II)
42	Local Controller Area Network between DME I and DME II

S63TU Engine

9. Engine Management System

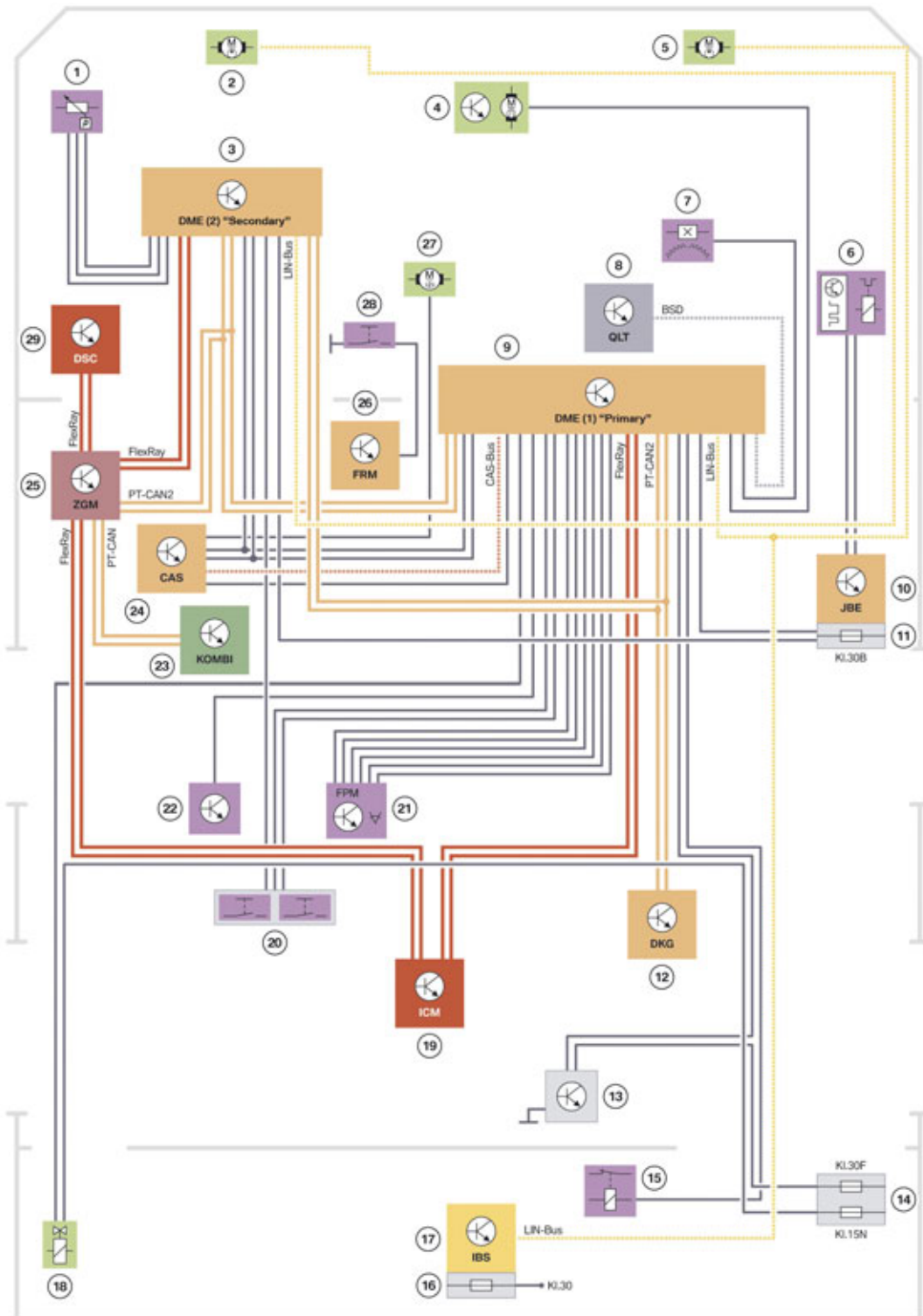

Vehicle interface, of DME I and DME II

TO11-1190

S63TU Engine

9. Engine Management System

Index	Explanation
1	Fuel pressure sensor
2	Electric coolant pump, charge air cooler and Digital Engine Electronics (DME II)
3	DME II
4	Electric fan
5	Electric coolant pump, charge air cooler and Digital Engine Electronics (DME I)
6	A/C compressor
7	Transmission speed sensor
8	Oil level sensor
9	DME I
10	Junction box (JB)
11	Fuse, terminal 30B
12	Twin-clutch gearbox, selector lever (not manual gearbox)
13	Tank leak diagnosis
14	Rear right power distribution box
15	Relay for electric fan
16	Fuse, terminal 30
17	Intelligent battery sensor (IBS)
18	Valve, exhaust flaps
19	Integrated Chassis Management (ICM)
20	Operating facility, Servotronic and power switch
21	Accelerator pedal module
22	Coupling switch module (manual gearbox only)
23	Instrument cluster
24	Car Access System (CAS)
25	Central gateway module (ZGM)
26	Footwell module (FRM)
27	Starter motor
28	Switch reversing light (manual gearbox only)
29	Dynamic Stability Control DSC

9.2. Engine control unit

The S63 top (S63TU) engine uses Digital Engine Electronics MEVD17.2.8, manufactured by Bosch. It is similar to the Digital Engine Electronics of the N55 engine. Both DME's are water-cooled and mounted to the engine.

S63TU Engine

9. Engine Management System

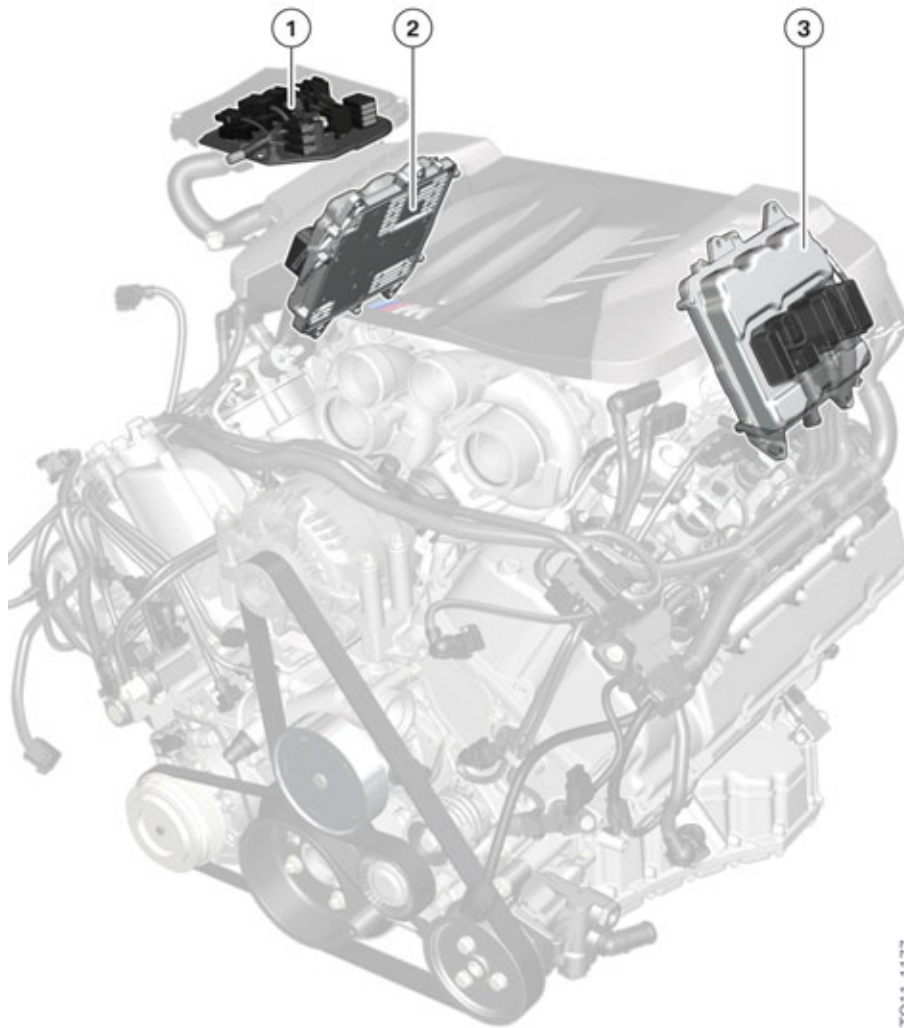

Digital Engine Electronics location

Index	Explanation
1	Carrier plate for fuses and relay
2	DME I, control unit, bank 1
3	DME II, control unit, bank 2



Do not attempt any trial replacement of control units.

Because of the electronic immobilizer, a trial replacement of control units from other vehicles must not be attempted under any circumstances. An immobilizer adjustment cannot be reversed.

The cooling of the two control units of the Digital Engine Electronics is integrated to the charge air cooling circuit. An aluminium cooling coil is integrated in the housing base of the control units for this system.

S63TU Engine

9. Engine Management System

The plug concept is identical to the MEVD17.2 in the N55 engine. There are six connections for each DME.

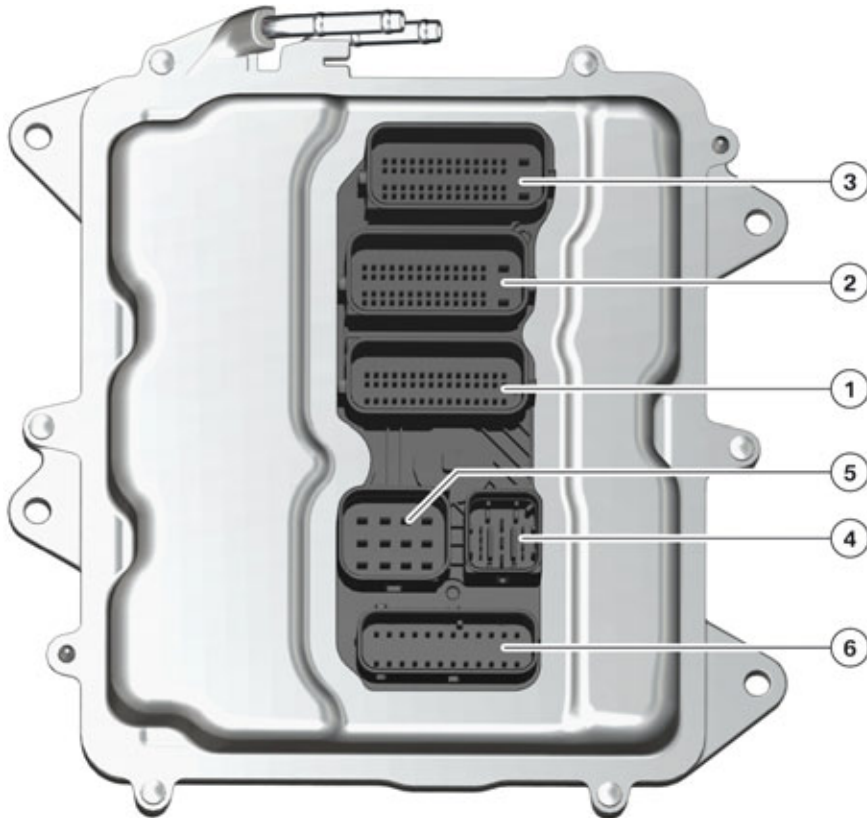

DME connections MEVD17.2.8

Index	Explanation
1	Module 100, vehicle connection, 48 pins
2	Module 200, sensors and actuators, 58 pins
3	Module 300, sensors and actuators, 58 pins
4	Module 400, Valvetronic servomotor, 11 pins
5	Module 500, DME supply, 12 pins
6	Module 600, fuel injection and ignition, 24 pins

9.2.1. Overall function

The Digital Engine Electronics (DME) is the computing and switching center of the engine control system. Sensors on the engine and the vehicle deliver the input signals. The signals for activating the actuators are calculated from the input signals, the nominal values calculated using a computing model in the DME control unit and the stored program maps. The DME control unit activates the actuators directly or by relays.

The DME control unit is woken up via the wake-up line (terminal 15 Wake up) by the Car Access System (CAS).

S63TU Engine

9. Engine Management System

The after-run starts after terminal 15 OFF. The adaptation values are stored during the after-run. The DME control unit uses a bus signal to signal its readiness to “go to sleep”. When all the participating control units have signalled their readiness to “go to sleep”, the bus I outputs a bus signal and the control units terminate communication five seconds later.

The circuit board in the DME control unit houses two sensors: a temperature sensor and an ambient pressure sensor. The temperature sensor is used to monitor the temperature of the components in the DME control unit. The ambient pressure is required for calculating the mixture composition.



Bayerische Motorenwerke Aktiengesellschaft
Händlerqualifizierung und Training
Röntgenstraße 7
85716 Unterschleißheim, Germany