

Reference Manual



N20 ENGINE



Technical Training

The information contained in this manual is not to be resold, bartered, copied or transferred without the express written consent of BMW of North America, LLC ("BMW NA").

Technical training.
Product information.

N20 Engine



BMW Service

Edited for the U.S. market by:
BMW Group University
Technical Training
ST1111 1/1/2013

General information

Symbols used

The following symbol / sign is used in this document to facilitate better comprehension and to draw attention to particularly important information:



Contains important safety guidance and information that is necessary for proper system functioning and which it is imperative to follow.

Information status and national-market versions

The BMW Group produces vehicles to meet the very highest standards of safety and quality. Changes in terms of environmental protection, customer benefits and design make it necessary to develop systems and components on a continuous basis. Consequently, this may result in differences between the content of this document and the vehicles available in the training course.

As a general principle, this document describes left-hand drive vehicles in the European version. Some controls or components are arranged differently in right-hand drive vehicles than those shown on the graphics in this document. Further discrepancies may arise from market-specific or country-specific equipment specifications.

Additional sources of information

Further information on the individual topics can be found in the following:

- Owner's Handbook
- Integrated Service Technical Application.

Contact: conceptinfo@bmw.de

©2010 BMW AG, Munich, Germany

Reprints of this publication or its parts require the written approval of BMW AG, Munich

The information in the document is part of the BMW Group technical training course and is intended for its trainers and participants. Refer to the latest relevant BMW Group information systems for any changes/supplements to the technical data.

Contacts

Gernot Nehmeyer/Udo Metz
Telephone +49 (0) 89 382 34059/+49 (0) 89 382 58506
gernot.nehmeyer@bmw.de/udo.metz@bmw.de

Information status: **November 2010**
BV-72/Technical Training

N20 Engine

Contents

1. Introduction	1
1.1. History	1
1.1.1. Historic BMW AG engines	1
1.1.2. Historic BMW M engines	3
1.2. Technical data	3
1.2.1. Comparison	4
1.3. New features/changes	6
1.3.1. Overview	6
1.4. Engine identification	7
1.4.1. Engine designation	7
1.4.2. Engine identification	8
2. Engine Components	11
2.1. Engine housing	11
2.1.1. Engine block	12
2.1.2. Cylinder head gasket	16
2.1.3. Cylinder head	17
2.1.4. Cylinder head cover	18
2.1.5. Oil sump	24
2.2. Crankshaft drive	27
2.2.1. Crankshaft with bearings	27
2.2.2. Connecting rod	42
2.2.3. Piston with piston rings	43
2.3. Camshaft drive	45
2.4. Counterbalance shafts	46
2.5. Valve gear	50
2.5.1. Design	50
2.5.2. Valvetronic	55
2.6. Belt drive	63
3. Oil Supply	65
3.1. Overview	65
3.1.1. Hydraulic circuit diagram	66
3.1.2. Oil passages	68
3.2. Oil pump and pressure control	73
3.2.1. Oil pump	73
3.2.2. Control	75
3.2.3. Pressure-limiting valve	83
3.3. Oil filtering and cooling	84
3.3.1. Oil cooling	84
3.3.2. Oil filtering	85

N20 Engine

Contents

3.4.	Oil monitoring.....	86
3.4.1.	Oil pressure and temperature sensor.....	86
3.4.2.	Oil level monitoring.....	87
3.5.	Oil spray nozzles.....	87
3.5.1.	Piston crown cooling.....	87
3.5.2.	Chain drive.....	88
3.5.3.	Camshaft.....	89
3.5.4.	Gearing, Valvetronic servomotor.....	91
4.	Cooling.....	93
4.1.	Overview.....	93
4.2.	Heat management.....	96
4.2.1.	Coolant pump.....	96
4.2.2.	Map thermostat.....	97
4.2.3.	Heat management function.....	97
4.3.	Internal engine cooling.....	98
5.	Air Intake/Exhaust Emission Systems.....	99
5.1.	Overview.....	99
5.2.	Intake air system.....	101
5.2.1.	Hot-film air mass meter.....	102
5.2.2.	Intake manifold.....	102
5.3.	Exhaust turbocharger.....	103
5.3.1.	Function of TwinScroll exhaust turbocharger.....	105
5.4.	Exhaust emission system.....	108
5.4.1.	Exhaust manifold.....	108
5.4.2.	Catalytic converter.....	108
6.	Vacuum System.....	110
7.	Fuel Preparation.....	112
7.1.	Overview.....	112
7.2.	Fuel pump control.....	113
7.3.	High-pressure pump.....	113
7.4.	Injectors.....	114
8.	Fuel Supply.....	117
8.1.	Tank ventilation.....	117
8.1.1.	Two-stage tank ventilation.....	117
8.1.2.	Two-stage tank ventilation with shutoff valve.....	119
9.	Engine Electrical System.....	122

N20 Engine

Contents

9.1.	Overview.....	122
9.2.	Engine control unit.....	124
9.2.1.	Overall function.....	126

N20 Engine

1. Introduction

BMW has decided to bring back the 4-cylinder engine to the US market. The last BMW 4-cylinder engine in the US was the M44, this lasted until 1999 and was installed in the E36 318is/318ti/Z3. Since then BMW in the US has not had a 4-cylinder engine. The N20 engine represents the new generation of BMW 4-cylinder gasoline engines. It will gradually be phased in on a number of BMW models starting in September 2011. The N20 will replace the N52 6-cylinder naturally aspirated engines. The N20 engine is equipped with the latest technology, such as TVDI (Turbocharged Valvetronic Direct Injection) in conjunction with a TwinScroll exhaust turbocharger. As a whole, it is closely related to the N55 engine, this is why constant reference is made to the N55 engine in this document.

1.1. History

The history of BMW 4-cylinder engines began back in 1927 with the BMW 3/15. From that point on, apart from an interruption stretching from 1936 to 1962, the 4-cylinder gasoline engines have again and again been the precursors to new technologies and have often also been forerunners. Thus, the M31 engine (predecessor of the M10 engine) was the world's first 4-cylinder production engine to feature a TwinScroll exhaust turbocharger and back in 1973 already achieving a power output of 125 kW / 167 bhp from a displacement of 2 liters. In motorsport the crankcase of the M10 with a displacement of 1.5 liters produced the first Formula 1 world champion with a turbocharged engine. In the world of motor racing performance figures of up to 1350 bhp from a displacement of 1.5 liters were achieved, figures which to date have only been achieved by BMW.

1.1.1. Historic BMW AG engines

Designation	Power output in bhp/rpm	Displacement in [cm ³]	Year of launch	Model	Series
DA 1, 2, 4*	15/3000	748	1927	BMW 3/15	3/15
DA 3*	18/3500	748	1930	Wartburg	3/15
M68*	20/3500	782	1932	BMW 3/20	3/20
M68*	22/4000	845	1934	BMW 309	309
M115**	75/5700	1499	1961	BMW 1500	115
M115** Available in the US	80/5500	1499	1962	BMW 1500	115
M116** Available in the US	83/5500	1573	1964	BMW 1600	116
M116**	85/5700	1573	1966	BMW 1600-2	114C
M116**	105/6000	1573	1967	BMW 1600ti	116
M116**	75/5800	1573	1975	BMW 1502	114
M118**	90/5250	1773	1963	BMW 1800	118
M118**	110/5800	1773	1964	BMW 1800ti	118

N20 Engine

1. Introduction

Designation	Power output in bhp/rpm	Displacement in [cm ³]	Year of launch	Model	Series
M118** Available in the US	130/6100	1773	1965	BMW 1800ti SA	118
M118** short-stroke	90/5250	1766	1968	BMW 1800	118
M118** short-stroke	90/5500	1766	1974	BMW 518	E12/4
M05** Available in the US	100/5500	1990	1965–1972	BMW 2000/2002	121
M05**	120/5500	1990	1965	BMW 2000ti	121
M15** Available in the US	130/5800	1990	1968	BMW 2000tii/2002tii	121
M17**	115/5800	1990	1972	BMW 520	E12/4
M31**	170/5800	1990	1974	BMW 2002 turbo	E20
M41**	90/6000	1573	1975	BMW 316	E21
M42**	98/5800	1766	1975	BMW 318	E12
M42**	90/5500	1766	1976	BMW 518	E12
M43/1**	109/5800	1990	1975	BMW 320	E21
M64**	125/5700	1990	1975	BMW 320i	E21
M10 (M92**)	105/5800	1766	1980	BMW 318i	E30
M10 (M99**)	90/5500	1766	1980	BMW 316/518	E30/E28
M98**	75/5800	1573	1981	BMW 315	E21
M10 Available in the US	102/5800	1766	1984	BMW 318i Cat	E30
M40B16	102/5500	1596	1988	BMW 316i	E30
M40B16	99/5500	1596	1988	BMW 316i Cat	E30
M40B18	116/5500	1796	1987	BMW 318i	E30
M40B18	113/5500	1796	1987	BMW 318i Cat BMW 518i Cat	E28/ E30/E34
M42B1800 Available in the US	140/6000	1796	1989	318is/318ti	E36

N20 Engine

1. Introduction

Designation	Power output in bhp/rpm	Displacement in [cm ³]	Year of launch	Model	Series
M43B16O0	102/5500	1596	1993	316i	E36
M43B16O0	87/5500	1596	1996	316g	E36
M43B18O0	116/5500	1796	1993	318i/518i/ Z3 1.8	E34/E36
M43B19U1	105/5300	1895	2000	316i	E46
M43B19O1	118/5500	1895	1998	318i/Z3 1.8	E36/E46
M44B19O0 Available in the US	149/6000	1895	1995	318is/318ti/ Z3 1.9	E36

* denotes engines up to 1933, ** denotes engines from 1957–1980, Cat = catalytic converter from M42/1989 data with and without catalytic converter.

Note: Not all engines in the chart above were available in the US market. The M44B19O0 was the last 4 cylinder engine available in the US up to the introduction of the N20 in 9/2011.

1.1.2. Historic BMW M engines

Designation	Power output in bhp/rpm	Displacement in [cm ³]	Year of launch	Model	Series
S14B23	197/6750	2302	1986	BMW M3	E30

1.2. Technical data

Model designation	Engine designation	Series introduction
Various BMW models	N20B20O0	2012 Model year

N20 Engine

1. Introduction

1.2.1. Comparison

N20B2000 engine compared with N52B3001 engine

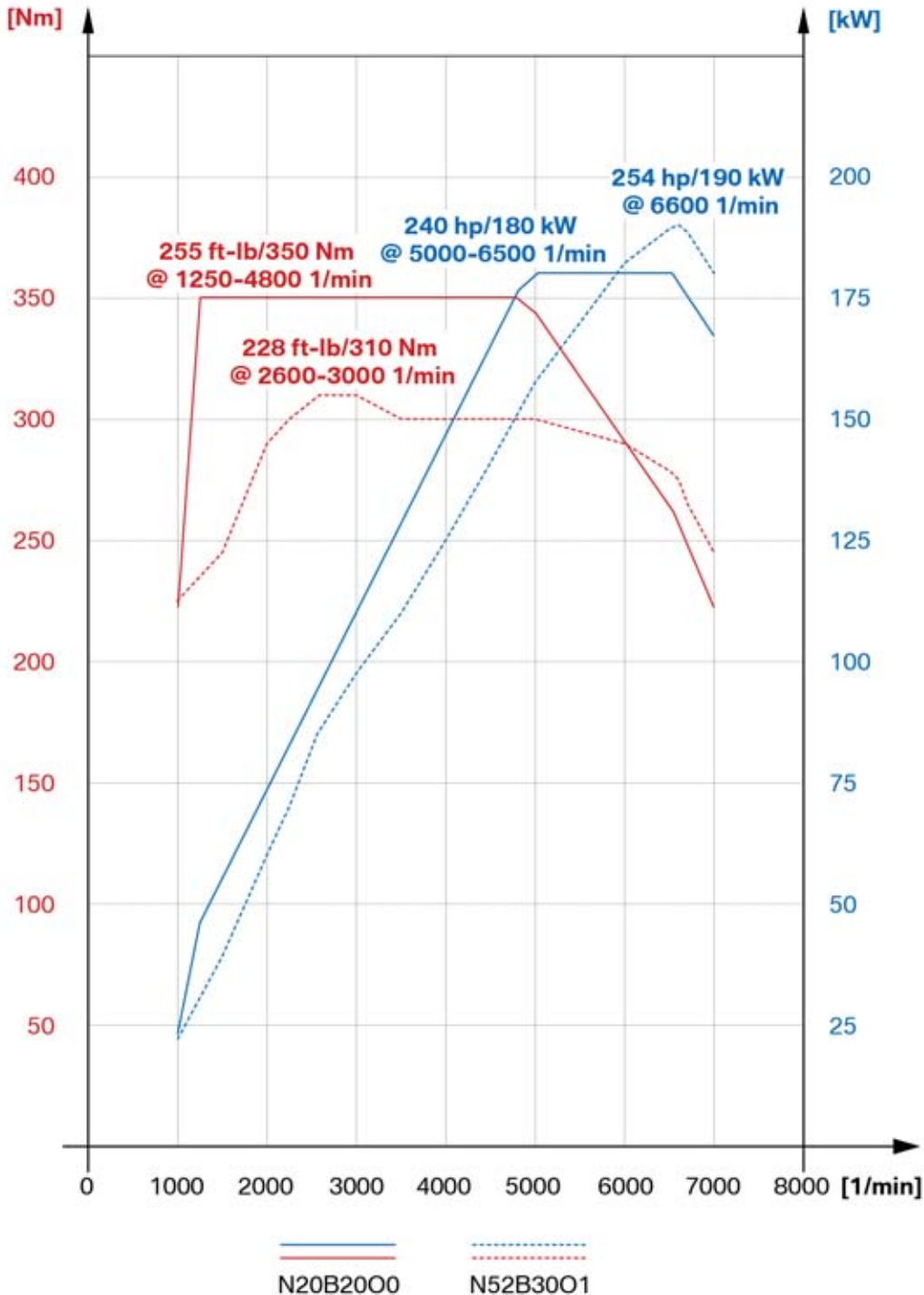

TO10-1737_2

Full-load diagram, N20B2000 engine compared with N52B3001 engine

N20 Engine

1. Introduction

	Unit	N52B30O1	N20B20O0
Design		Inline 6	Inline 4
Displacement	[cm ³]	2996	1997
Bore/stroke	[mm]	85/88	84/90.091
Power output at engine speed	kW/bhp [rpm]	190/254 6600	180/240 5000 - 6500
Power output per liter	[kW/l]	63.4	90.14
Torque at engine speed	Nm/ft-lbs [rpm]	310/228 2600 - 3000	350/255 1250 - 4800
Compression ratio	[ε]	10.7	10.0 : 1
Valves per cylinder		4	4
Fuel consumption	l/100 km	9.9	7,9
CO₂ emissions	[g/km]	230	183
Digital Engine Electronics		MSV80	MEVD17.2.4
Exhaust emissions legislation		ULEV II	ULEV II

N20 Engine

1. Introduction

1.3. New features/changes

1.3.1. Overview

System	Comment
Engine mechanical components	<ul style="list-style-type: none"> Aluminium crankcase with coated cylinder bore Optimized cooling jackets Use of the TVDI technology TwinScroll exhaust turbocharger 3rd generation Valvetronic with new intermediate levers New generation VANOS with central valves Assembled camshafts Two mode crankcase ventilation Forged crankshaft Positive crankshaft offset Piston with negative pin offset Chain drive for counterbalance shafts with chain tensioner Counterbalance shafts arranged on top of one another.
Oil supply	<ul style="list-style-type: none"> Map-controlled oil pump New pendulum-slide oil pump design Unfiltered oil cooling New combined oil pressure and temperature sensor.
Cooling	<ul style="list-style-type: none"> Electric coolant pump Map controlled thermostat.
Air intake and exhaust emission systems	<ul style="list-style-type: none"> TwinScroll exhaust turbocharger Hot-film air mass meter Enhanced crankcase ventilation.

N20 Engine

1. Introduction

System	Comment
Vacuum system	<ul style="list-style-type: none">Two-stage vacuum pumpVacuum reservoir for the wastegate valve is built into the engine cover.
Fuel preparation	<ul style="list-style-type: none">High-pressure injection (as N55)Solenoid valve injectorsBosch high-pressure pumpHigh-pressure lines to the injectors are soldered to the railNo fuel low-pressure sensor.
Engine electrical system	<ul style="list-style-type: none">Bosch MEVD17.2.4 engine control unit.

1.4. Engine identification

1.4.1. Engine designation

The N20 engine is described in the following version: N20B2000.

The technical documentation also features the short form of the engine designation N20, which only allows assignment of the engine type.

Item	Meaning	Index / explanation
1	Engine developer	M, N = BMW Group P = BMW Motorsport S = BMW M GmbH W = non-BMW engines
2	Engine type	1 = Inline 4 (e.g. N12) 2 = Inline 4 (e.g. N20) 4 = Inline 4 (e.g. N43) 5 = Inline 6 (e.g. N53) 6 = V8 (e.g. N63) 7 = V12 (e.g. N73) 8 = V102 (e.g. S85)
3	Change to the basic engine concept	0 = basic engine 1 to 9 = changes, e.g. combustion process
4	Working method or fuel type and possibly installation position	B = gasoline, longitudinal installation D = diesel, longitudinal installation H = hydrogen
5	Displacement in liters	1 = 1 liter +

N20 Engine

1. Introduction

Item	Meaning	Index / explanation
6	Displacement in 1/10 liter	8 = 0.8 liters = 1.8 liters
7	Performance class	K = Smallest U = Lower M = Middle O = Upper (standard) T = Top S = Super
8	Revision relevant to approval	0 = New development 1 – 9 = Revision

Breakdown of N20 engine designation

Index	Explanation
N	BMW Group Development
2	4-cylinder in-line engine
0	Engine with exhaust turbocharger, Valvetronic and direct fuel injection (TVDI)
B	Gasoline engine, longitudinally installed
20	2.0 liters displacement
O	Upper performance class
0	New development

1.4.2. Engine identification

The engines have an identification mark on the crankcase to ensure proper identification and classification.

With the N55 engine, this identification was subject to a further development, with the previous eight positions being reduced to seven. The engine number can be found on the engine below the engine identification. This consecutive number, in conjunction with the engine identification, allows proper identification of each individual engine.

N20 Engine

1. Introduction

Item	Meaning	Index / explanation
1	Engine developer	M, N = BMW Group P = BMW Motorsport S = BMW M GmbH W = non-BMW engines
2	Engine type	1 = Inline 4 (e.g. N12) 2 = Inline 4 (e.g. N20) 4 = Inline 4 (e.g. N43) 5 = Inline 6 (e.g. N53) 6 = V8 (e.g. N63) 7 = V12 (e.g. N73) 8 = V102 (e.g. S85)
3	Change to the basic engine concept	0 = basic engine 1 to 9 = changes, e.g. combustion process
4	Working method or fuel type and possibly installation position	B = gasoline, longitudinal installation D = diesel, longitudinal installation H = hydrogen
5	Displacement in liters	1 = 1 liter +
6	Displacement in 1/10 liter	8 = 0.8 liters = 1.8 liters
7	Type test concerns (changes that require a new type test)	A = Standard B - Z = depending on requirement, e.g. RON 87

N20 Engine

1. Introduction

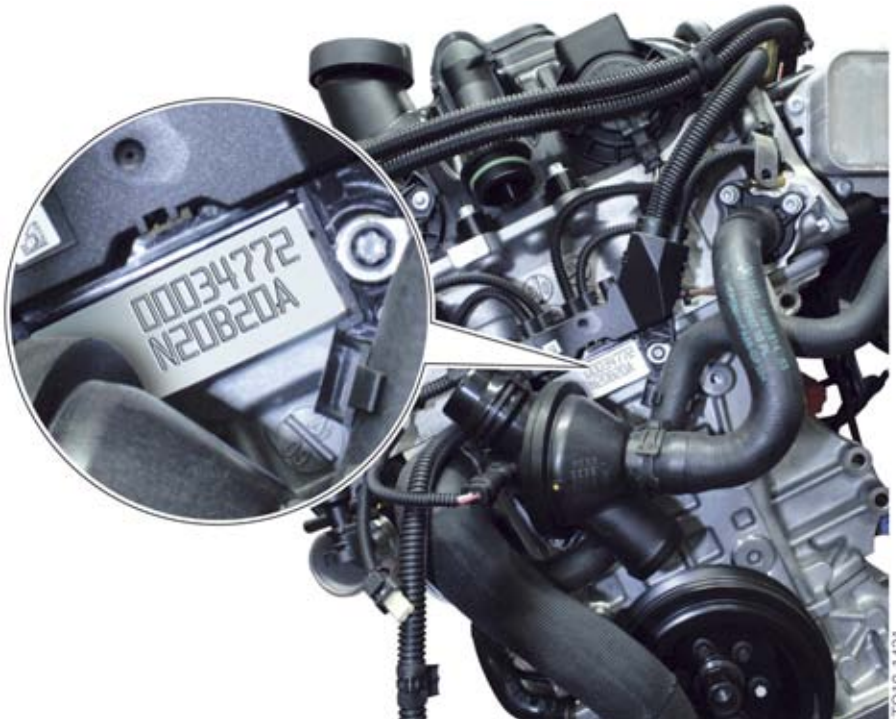

N20 engine number, engine identification and engine number

Index	Explanation
00034772	Individual consecutive engine number
N	Engine developer, BMW Group
2	Engine type, Inline 4
0	Change to the basic engine concept, Turbocharged Valvetronic Direct Injection
B	Operating principle or fuel type and installation position, gasoline longitudinal installation
20	Displacement in 1/10 liter, 2 liters
A	Type test concerns, standard

N20 Engine

2. Engine Components

2.1. Engine housing

The engine housing comprises the engine block (crankcase and bedplate), the cylinder head, the cylinder head cover, the oil sump and the gaskets.

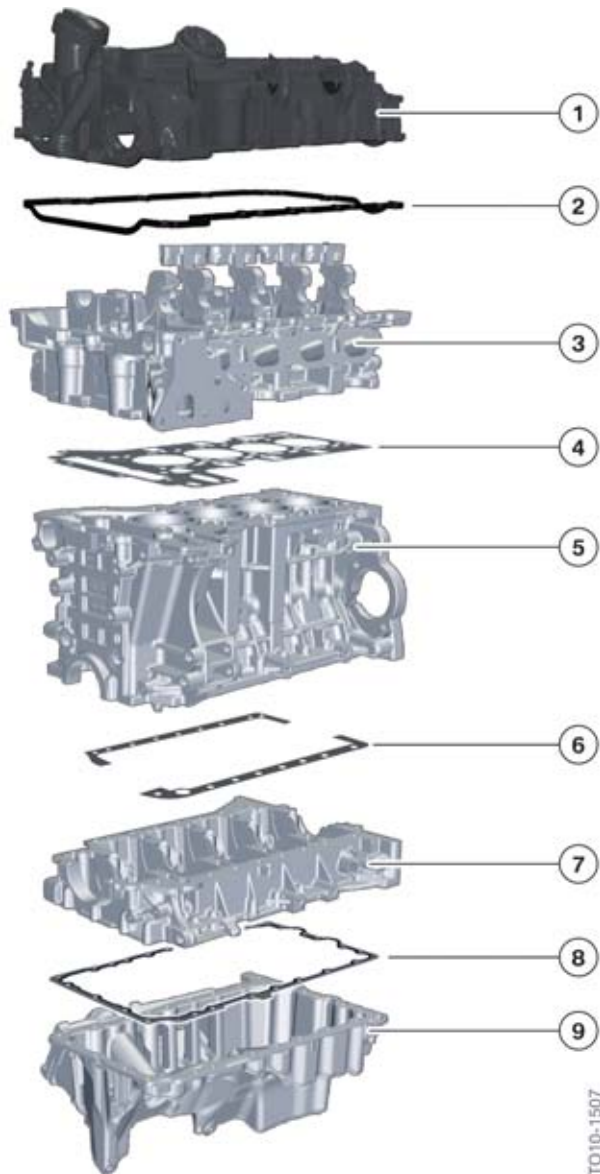

N20 engine, structure of engine housing

Index	Explanation
1	Cylinder head cover
2	Cylinder head cover gasket
3	Cylinder head
4	Cylinder head gasket
5	Crankcase

N20 Engine

2. Engine Components

Index	Explanation
6	Sealant
7	Bedplate
8	Oil sump gasket
9	Oil sump

2.1.1. Engine block

The engine block is made from diecast aluminium AlSi9Cu3 along with the crankcase and the bedplate. A new coating for the cylinder wall is being used for the first time by BMW. Its referred to as electric arc wire spraying.

The cooling jacket has also been optimized to improve cooling between the cylinders, this is due to the requirements of a turbocharged engine.

Oil passages

The graphic below shows the oil passages in the engine block.

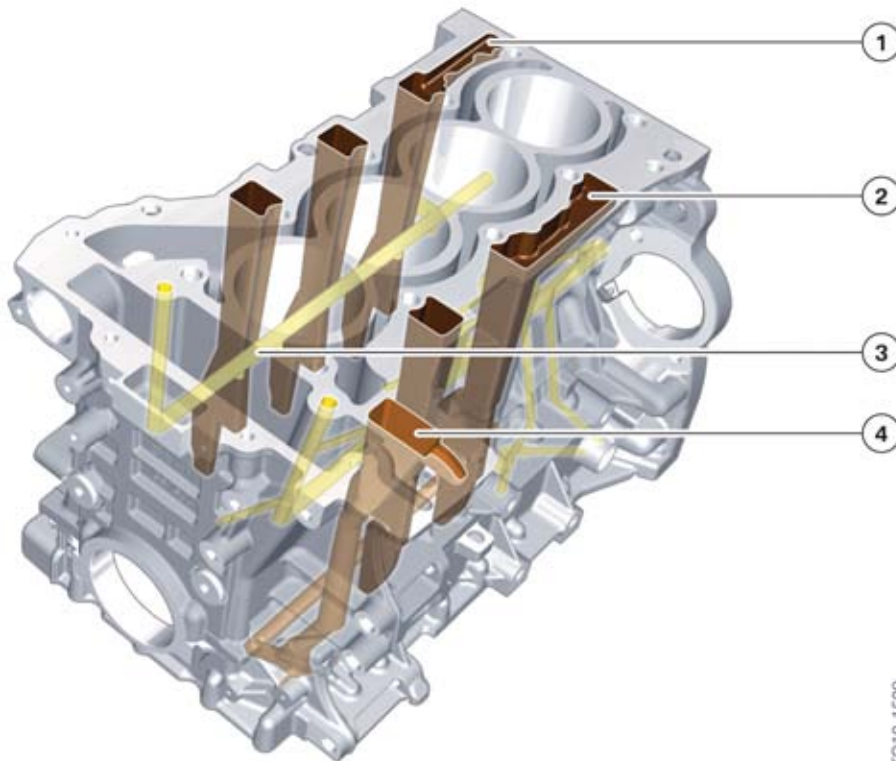

N20 engine, oil passages

TO10-1509

N20 Engine

2. Engine Components

Index	Explanation
1	Oil return duct
2	Blow-by duct
3	Clean oil passages
4	Unfiltered oil passages

Coolant ducts

The graphic below shows the coolant passages in the engine block.

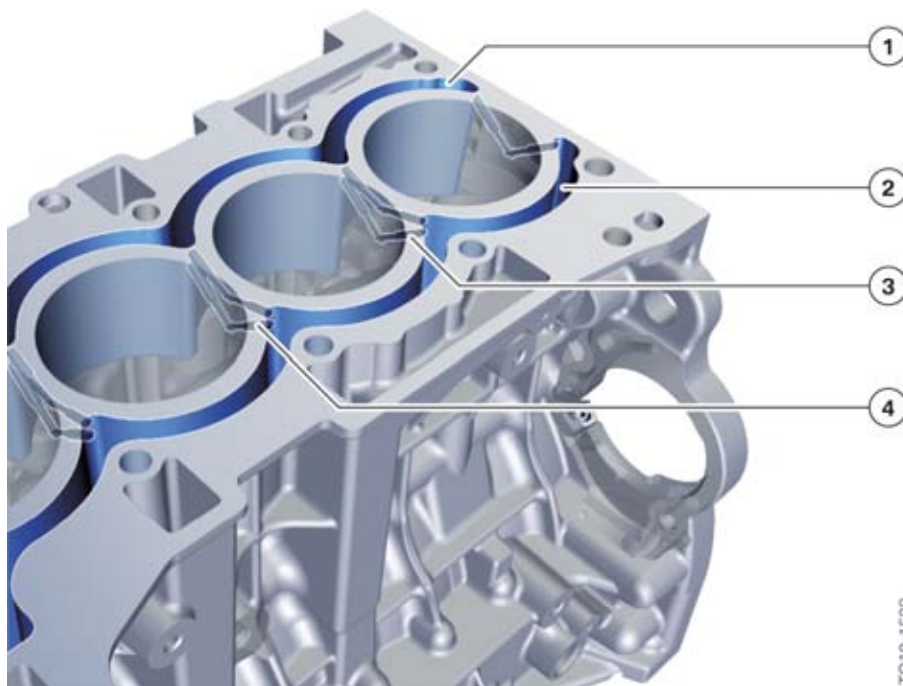

N20 engine, cooling jacket and coolant passages

Index	Explanation
1	Cooling jacket, exhaust side
2	Cooling jacket, intake side
3 + 4	Coolant passages between the cylinders

Compensation openings

The crankcase features large milled longitudinal ventilation holes. These ventilation holes improve the pressure compensation of the oscillating air columns created by the up and down strokes of the pistons.

Additional openings on the intake side on the bearing seat between the cylinders also improve crankcase pressure.

N20 Engine

2. Engine Components

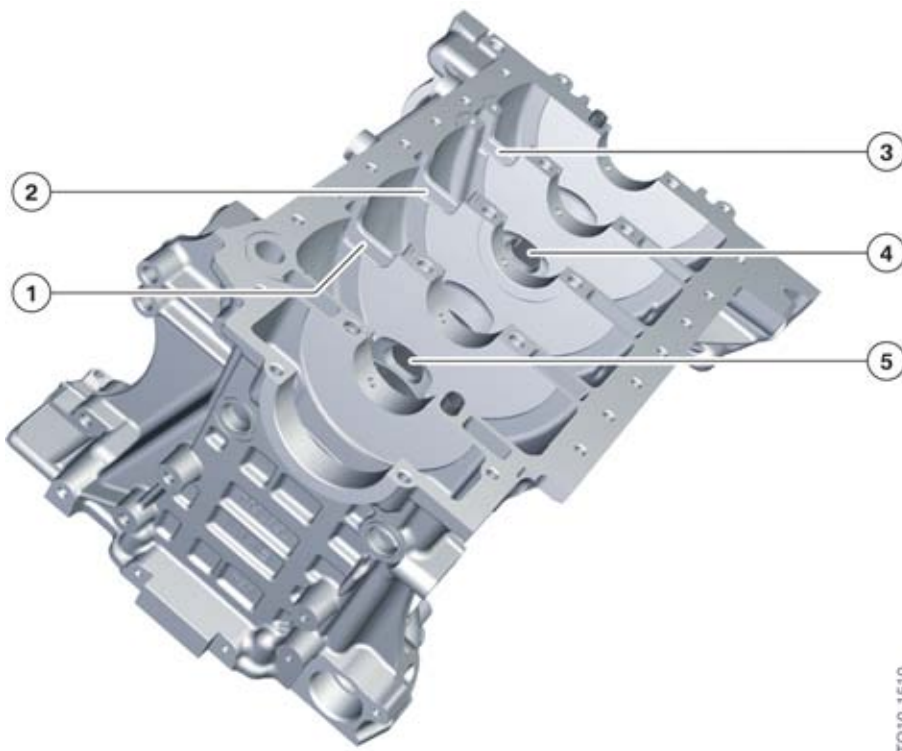

T010-1510

N20 engine, compensation openings in the bearing seat

Index	Explanation
1 + 2 + 3	Openings
4 + 5	Ventilation holes

Cylinder

An iron wire is used in the electric arc wire spraying process (arc spray process) to coat the aluminium cylinder bores. High voltage is used to ignite an electric arc at both ends of the wire. The temperatures generated in the process are in the region of 3000 °C / 5432 °F. The high temperatures melt the wire, which is continually fed by the wire feed unit. The molten iron is blasted onto the cylinder wall surface at pressure via the central and secondary compressed-air supplies.

The liquid iron adheres to the aluminium surface through:

- **Mechanical bonding:**
Molten particles penetrate as a result of high kinetic energy and capillary action into depressions and undercuts, where they solidify to create a very strong coating.

N20 Engine

2. Engine Components

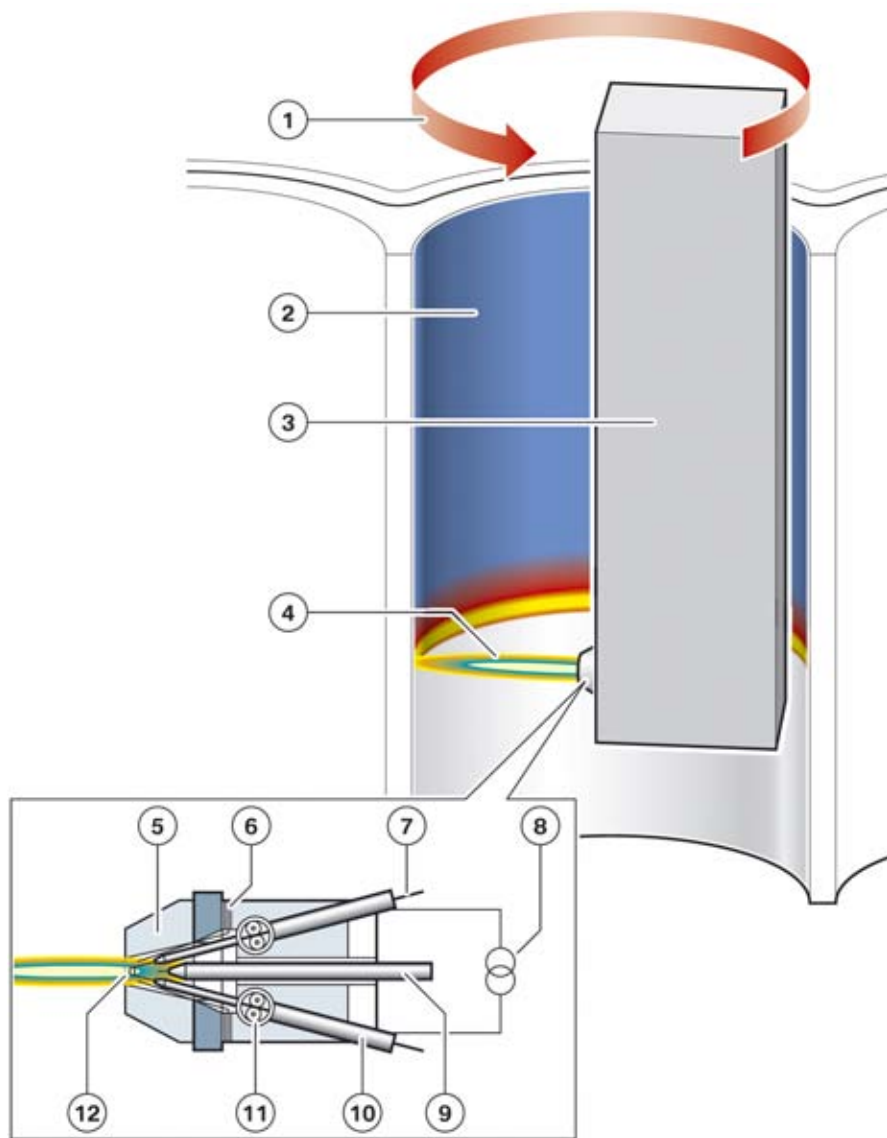

TO10-1166

Electric arc spraying

Index	Explanation
1	Direction of movement
2	Coated cylinder surface
3	EAS unit
4	Spray jet
5	Nozzle
6	Secondary compressed-air supply
7	Spray wire
8	Power supply

N20 Engine

2. Engine Components

Index	Explanation
9	Central compressed-air supply
10	Contact tube
11	Wire feed unit
12	Electric arc

Advantages:

- Spray particles adhere with the base metal
- Ideal for thick coatings or large surfaces
- Greatest application rate per hour of all the thermal spraying processes
- The arc spray coating can barely be distinguished in terms of color from the base metal
- The low-oxide spray coating can be processed during manufacturing like a solid material
- High tensile strength and lower contraction strain
- Micro-porous surface reduces friction
- Coating properties such as coating hardness or surface quality can be determined
- All materials can be added as coatings, such as for example ferrous/nonferrous alloy on cast iron
- Low thermal stress thanks to optimized heat transfer.



The low coating thickness of about 1mm produces optimum heat transfer but does not allow reworking of the cylinder bore surface in service.

If a cylinder is determined out of specification the entire engine block must be replaced.

2.1.2. Cylinder head gasket

A three-layer spring steel gasket is used for the cylinder head gasket. A stopper plate (2) is welded on in the area of the cylinder bores in order to achieve sufficient contact pressure for sealing. All the layers of the gasket are coated, the cylinder head and the engine block contact surfaces are coated with a partial fluorocarbon (elastomer) with non-stick coating.

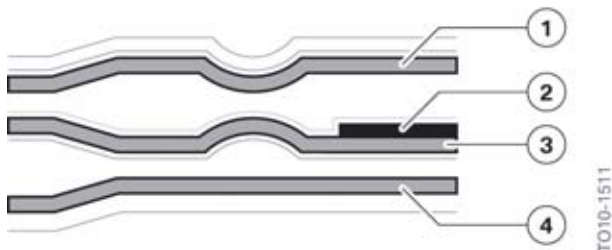

N20 engine, cylinder head gasket

N20 Engine

2. Engine Components

Index	Explanation
1	Top spring steel layer with non-stick coating
2	Welded-on stopper plate
3	Middle spring steel layer with coating
4	Bottom spring steel layer with non-stick coating

2.1.3. Cylinder head

The cylinder head in the N20 engine is similar to the cylinder head in the N55. The 3rd generation Valvetronic system introduced in the N55 is also used in the N20 engine.

The classic VANOS with separate solenoid valve in the N55 engine has been replaced in the N20 engine by a central VANOS with integrated solenoid valve. The benefit of this system is a reduced number of oil passages in the cylinder head.

As in the N55 engine the N20 also uses TVDI technology.



The combination of exhaust turbocharger, Valvetronic and direct fuel injection is known as **Turbo Valvetronic Direct Injection (TVDI)**.

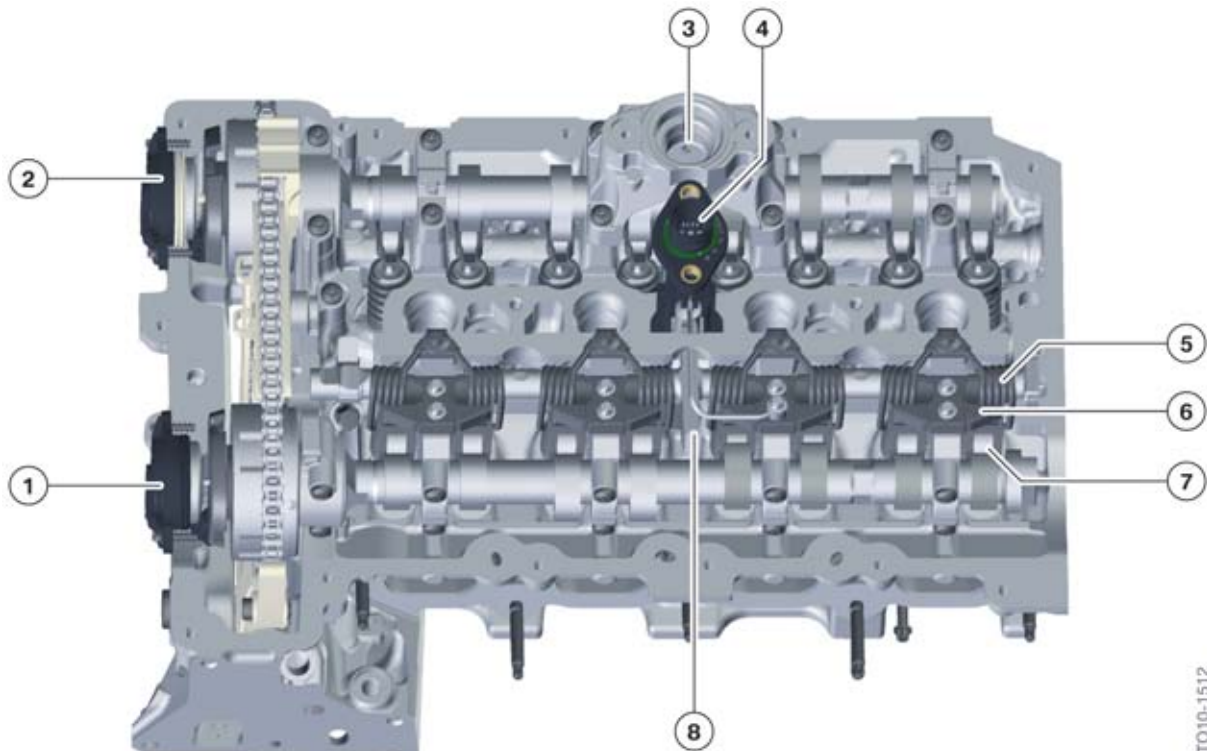

N20 engine, cylinder head

TO10-1512

N20 Engine

2. Engine Components

Index	Explanation
1	VANOS solenoid actuator, intake
2	VANOS solenoid actuator, exhaust
3	Roller tappet, high-pressure pump
4	Valvetronic servomotor
5	Spring
6	Guide block
7	Intermediate lever
8	Eccentric shaft

2.1.4. Cylinder head cover

Design

The cylinder head cover is a new development. All the components for crankcase ventilation and the blow-by ducts are integrated into the cover. A pressure control valve prevents an excessive vacuum from being generated in the crankcase. Ventilation is performed via different ducts depending on whether the engine is running in turbocharged (Boost) or normally aspirated (NA) mode.

In NA mode, ventilation is performed via the pressure control valve at about 38 mbar.

N20 Engine

2. Engine Components

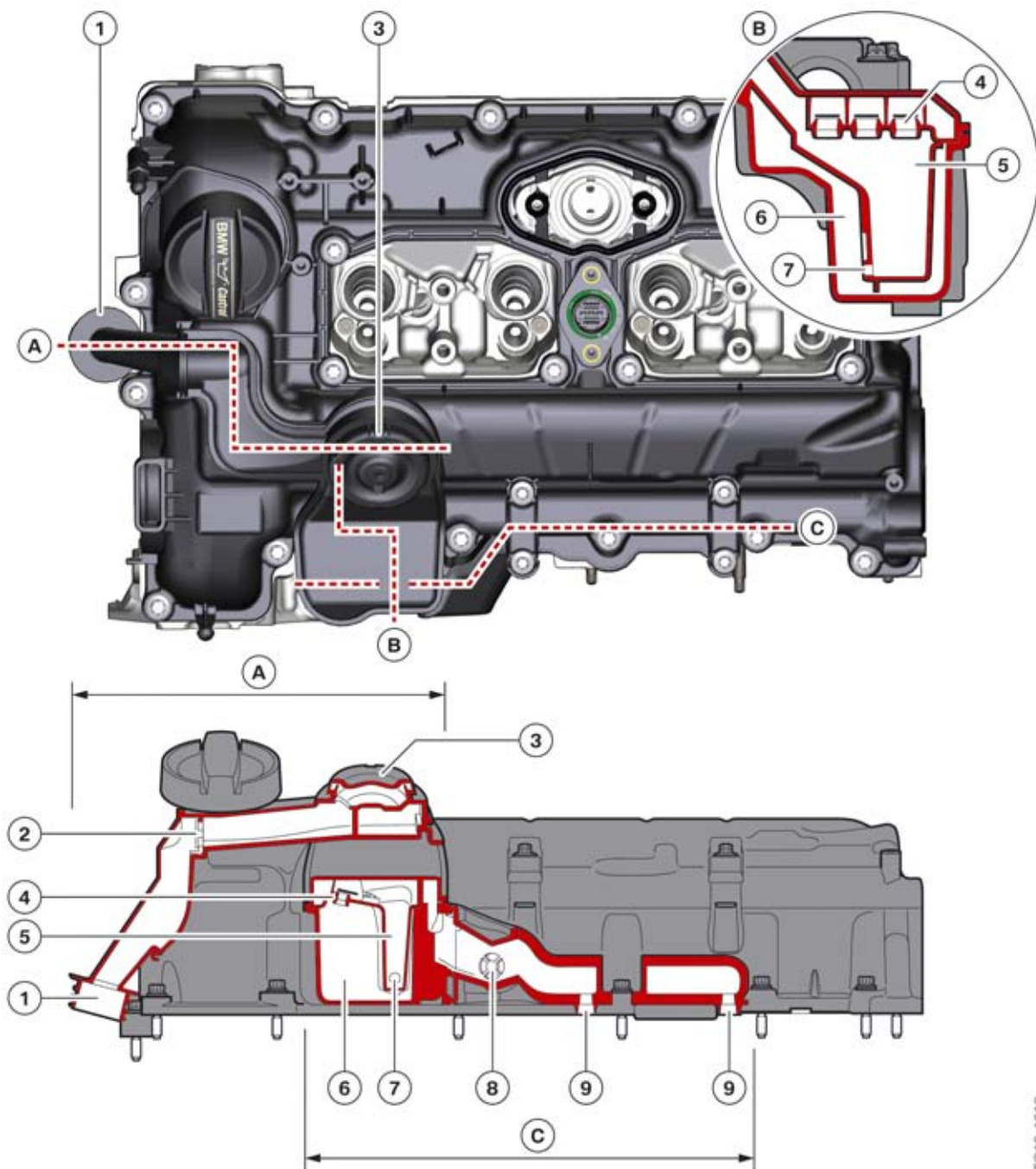

N20 engine, cylinder head cover with crankcase ventilation

TO10-1513

Index	Explanation
A	Section A
B	Section B
C	Section C
1	Connection to clean air pipe ahead of exhaust turbocharger

N20 Engine

2. Engine Components

Index	Explanation
2	Non-return valve
3	Pressure control valve
4	Spring tab separator
5	Oil separator
6	Settling chamber
7	Non-return valve
8	Non-return valve
9	Blow-by duct to the intake ports in the cylinder head

The blow-by gases pass through the opening in the intake side area of cylinder one to the three spring tab separators. The oil in the blow-by gas is separated by the spring tab separators, and flows along the walls down through a non-return valve and back into the cylinder head. The blow-by gas separated from the oil now passes into the air intake system ports or fresh air pipe (depending on the operating mode).

Function

In naturally aspirated mode, the non-return valve in the blow-by duct of the cylinder head cover is opened by the vacuum pressure in the air intake system and the blow-by gases are drawn off via the pressure control valve. The vacuum pressure simultaneously closes the second non-return valve in the duct to charge-air suction/fresh air line.

The blow-by gases are routed directly into the cylinder head intake ports via the passages integrated in the cylinder head cover .

A purge air line, which is connected to the fresh air pipe ahead of the turbocharger and to the crankcase, routes fresh air via a non-return valve directly into the crankcase. The greater the vacuum in the crankcase, the higher the air mass introduced. This purging prevents the pressure control valve from icing up by reducing moisture in the system.

N20 Engine

2. Engine Components

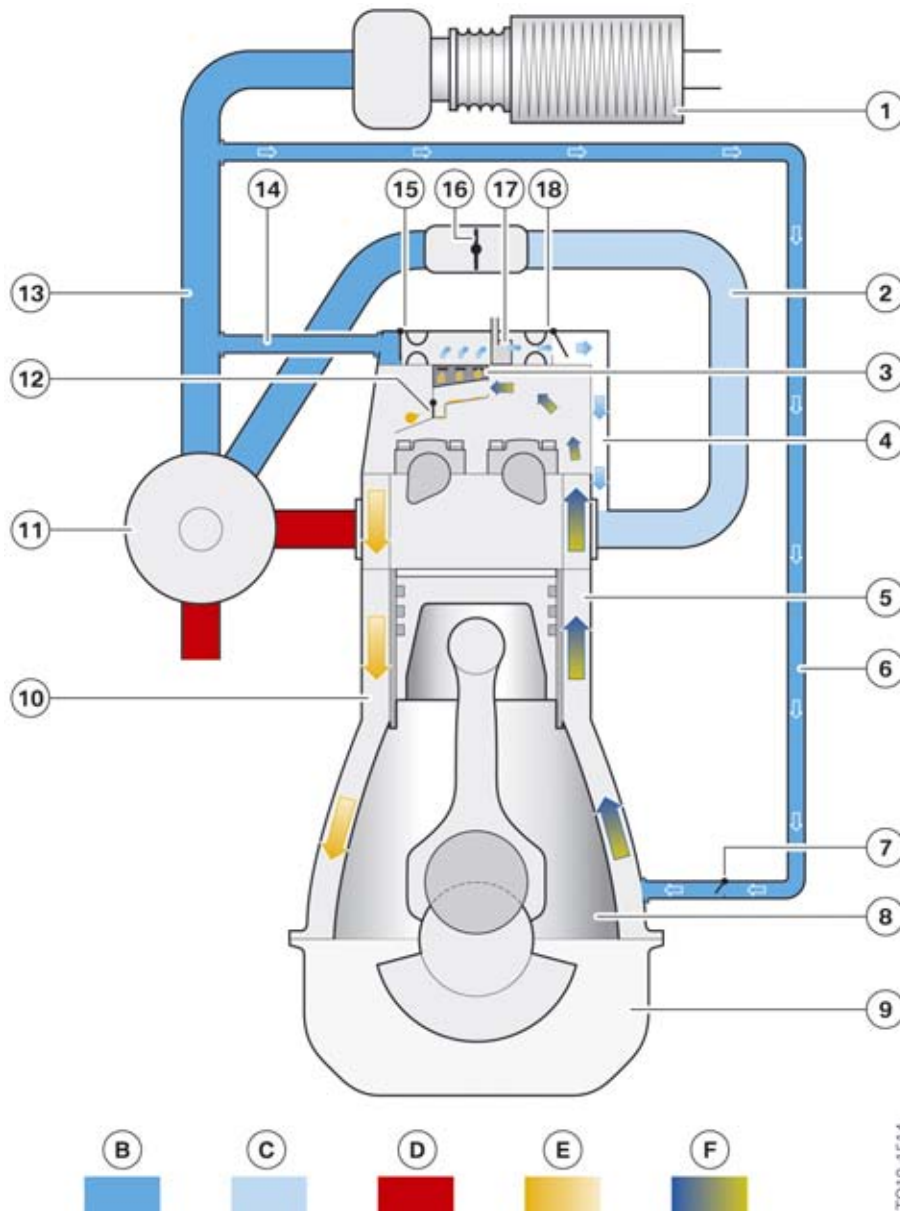

N20 engine, crankcase ventilation, naturally aspirated mode

Index	Explanation
B	Ambient pressure
C	Vacuum
D	Exhaust gas
E	Oil
F	Blow-by gas
1	Air filter
2	Intake plenum

N20 Engine

2. Engine Components

Index	Explanation
3	Perforated plates
4	Passages in cylinder head and cylinder head cover
5	Blow-by gas duct
6	Purge air line
7	Non-return valve
8	Crankcase
9	Oil sump
10	Oil return passage
11	Turbocharger
12	Non-return valve, oil return
13	Charge-air suction line/fresh air pipe
14	Connection to charge-air suction line
15	Non-return valve with restrictor
16	Throttle valve
17	Pressure control valve
18	Non-return valve with restrictor

Once in boost mode the pressure in the intake plenum rises thus it is no longer possible for the blow-by gases to be introduced via this route. A non-return valve in the blow-by duct of the cylinder head cover closes the duct to the intake plenum and thereby protects the crankcase against excess pressure.

The now greater fresh-air demand generates a vacuum in the fresh air pipe between the turbocharger and the intake silencer. This vacuum is sufficient to open the non-return valve in the cylinder head cover and draw off the blow-by gases directly without regulation. The pressure control valve (17) is bypassed in this mode, since only a low vacuum is generated which does not have to be limited.

N20 Engine

2. Engine Components

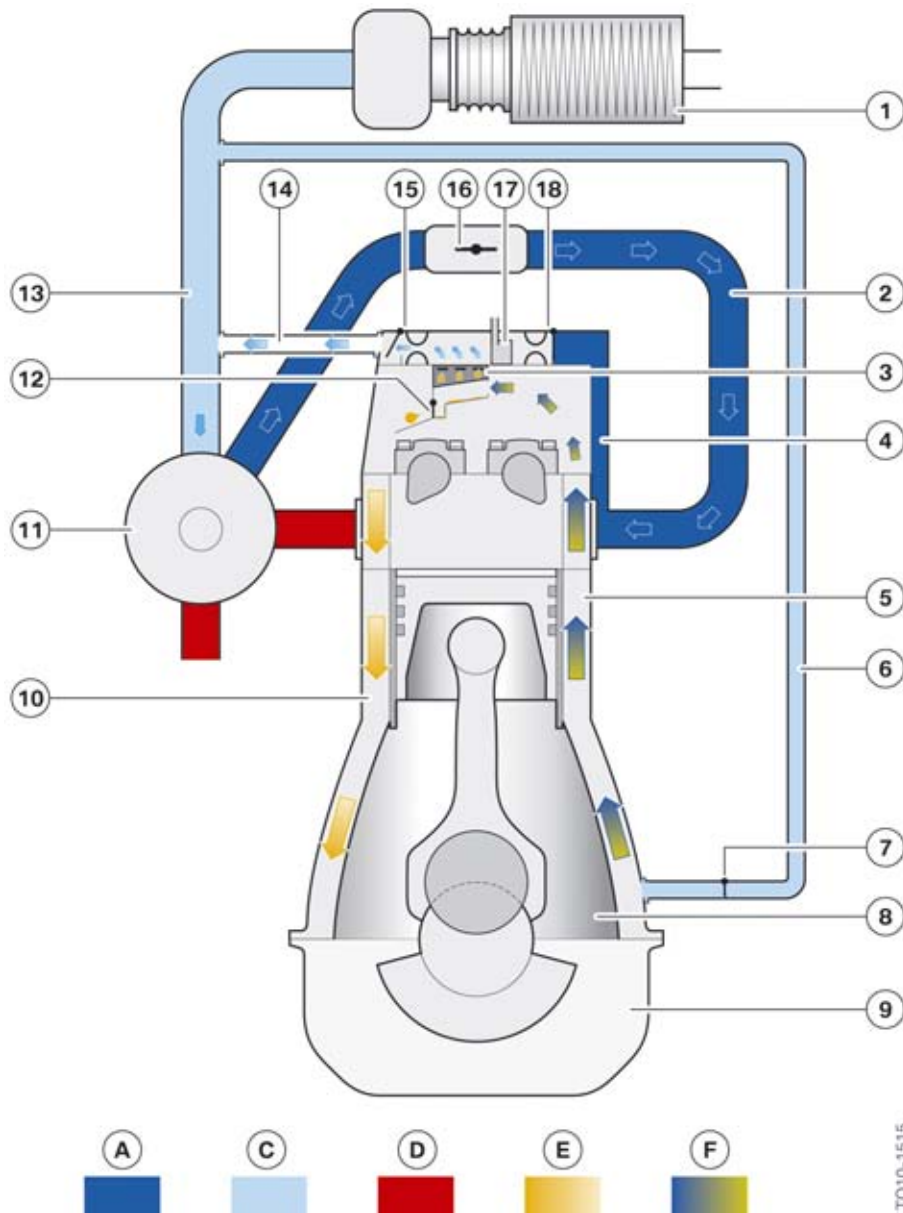

N20 engine, crankcase ventilation, boost mode

Index	Explanation
A	Charging pressure
C	Vacuum
D	Exhaust gas
E	Oil
F	Blow-by gas
1	Air filter
2	Intake plenum

N20 Engine

2. Engine Components

Index	Explanation
3	Perforated plates
4	Passages in cylinder head and cylinder head cover
5	Blow-by gas duct
6	Purge air line
7	Non-return valve
8	Crank chamber
9	Oil sump
10	Oil return passage
11	Turbocharger
12	Non-return valve, oil return
13	Charge-air suction line/clean air pipe
14	Connection to charge-air suction line
15	Non-return valve with restrictor
16	Throttle valve
17	Pressure control valve
18	Non-return valve with restrictor

2.1.5. Oil sump

The oil sump is made from plastic for rear wheel drive vehicles and cast aluminium for xDrive models. For xDrive vehicles the oil sump has been modified due to the input shafts and attachment points for the axle drive.

The oil pump with the counterbalance shafts covers the entire oil sump and thereby protects the crankshaft against “oil splashing” by doubling as a windage tray. The oil flowing back through the oil return passages is routed directly into the oil sump and therefore cannot come into contact with the crankshaft.

N20 Engine

2. Engine Components

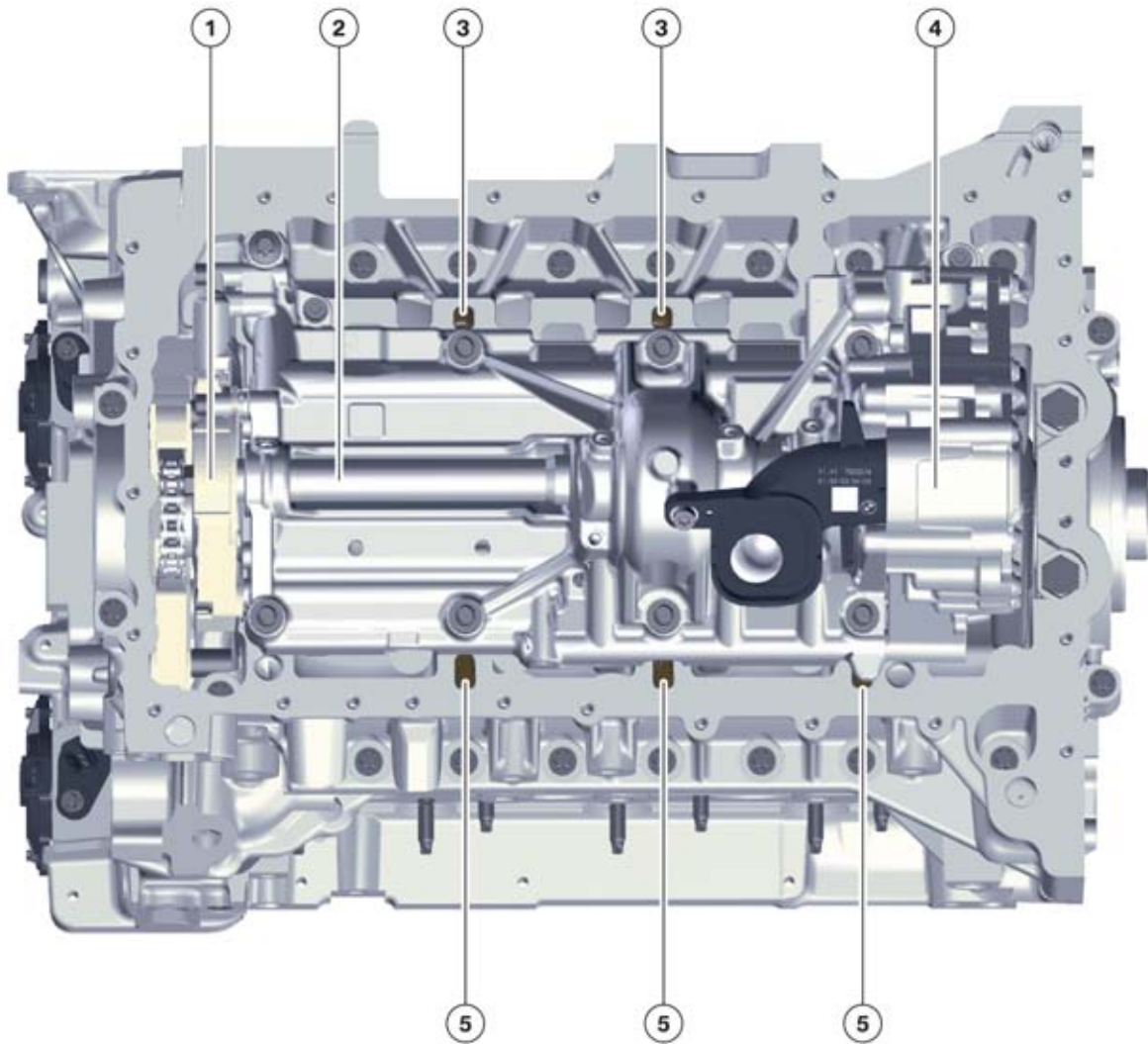

TO10-1517

N20 engine, oil pump with counterbalance shafts

Index	Explanation
1	Chain drive
2	Counterbalance shaft
3	Oil return ducts, intake side
4	Oil pump
5	Oil return ducts, exhaust side

N20 Engine

2. Engine Components

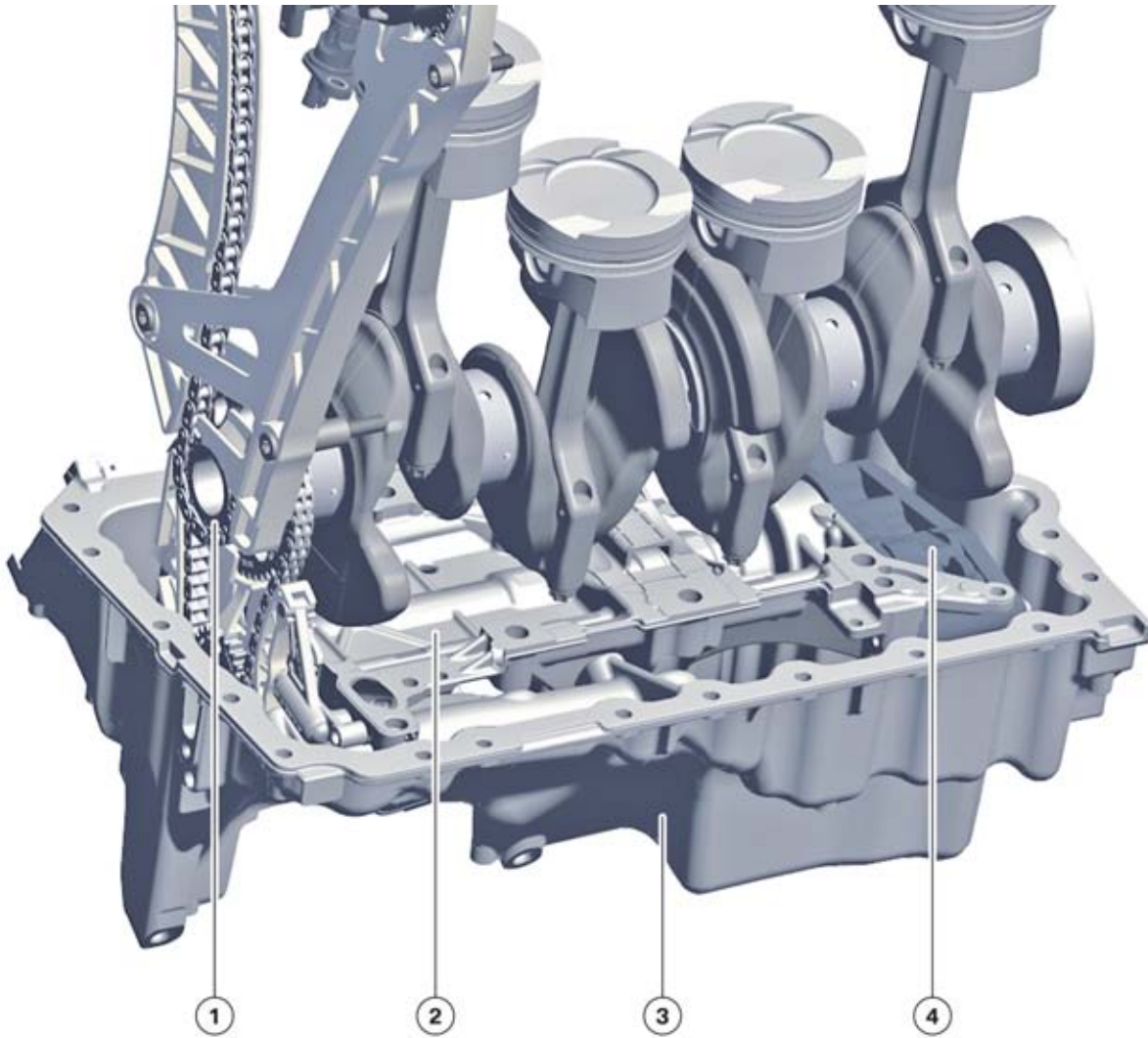

TO10-151B

N20 engine, oil sump with oil pump and counterbalance shafts

Index	Explanation
1	Chain drive
2	Housing, counterbalance shafts
3	Oil sump
4	Oil pump

N20 Engine

2. Engine Components

2.2. Crankshaft drive

2.2.1. Crankshaft with bearings

Crankshaft

The crankshaft of the N20 engine has a stroke of 89.6 mm and is made of the material C38modBY. It is a forged crankshaft with four balance weights and weighs 13.9 kg/30.6 lbs.

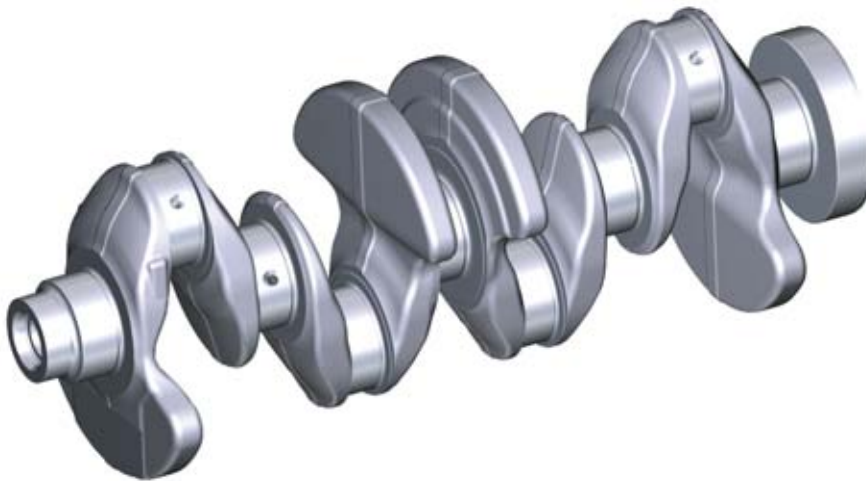

N20 engine, crankshaft

TO10-1519

Crankshaft bearings and rod bearings

The crankshaft is supported by five (lead-free two component) bearings. The thrust bearing is located in the middle at the third bearing position. The thrust bearing is only designed for 180° and is located in the bearing seat. The bearing in the bearing cap does not provide any axial guidance.

N20 Engine

2. Engine Components

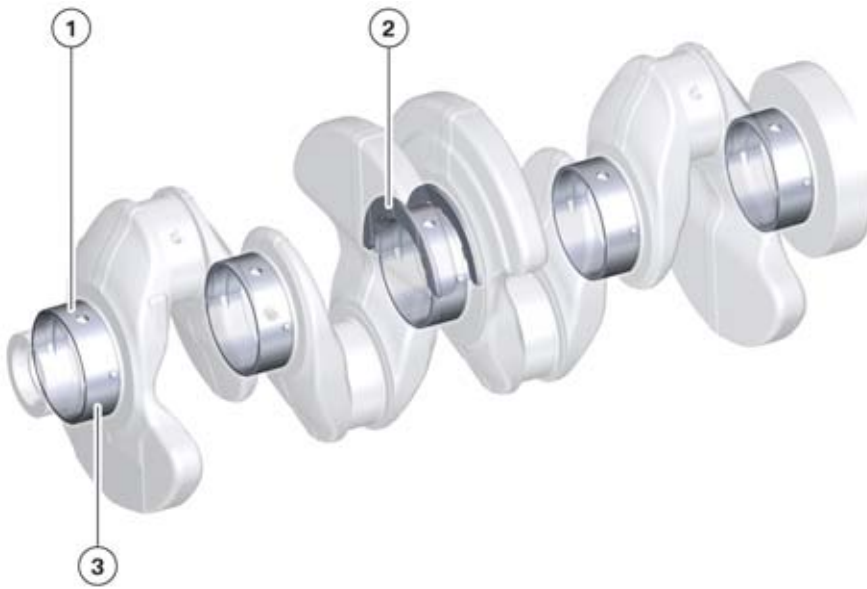

N20 engine, crankshaft bearings

Index	Explanation
1	Upper bearing shell with groove and oil hole
2	Thrust bearing with groove and oil hole
3	Lower bearing shell without groove



The N20 uses the same procedure as with N55 for calculating the correct bearing size by using the crankcase and crankshaft codes.

The identification markings for the upper bearings are found stamped on the crankcase and for the lower bearings on the crankshaft. If the crankshaft is to be fitted with new bearings **refer to the repair instructions** for more information on the procedure to determine the correct bearing size/color.

N20 Engine

2. Engine Components



N20 engine, bearing identification, crankshaft code

Index	Explanation
1	Code digits for crankshaft bearings (21211)
2	Code letters for connecting rod bearings (rrrr)

Two bearing categories are used. These bearing categories are “r” and “b”.

The following applies to the bearing position and bearing allocation:

Bearing category or code letter	Installation location	Bearing color
b	Rod end	Violet
	Bearing cap end	Blue
r	Rod end	Yellow
	Bearing cap end	Red

The bearing shells are identical parts to those used in the N54 and N55 engines. A locating groove prevents the wrong bearing shell from being installed.

N20 Engine

2. Engine Components

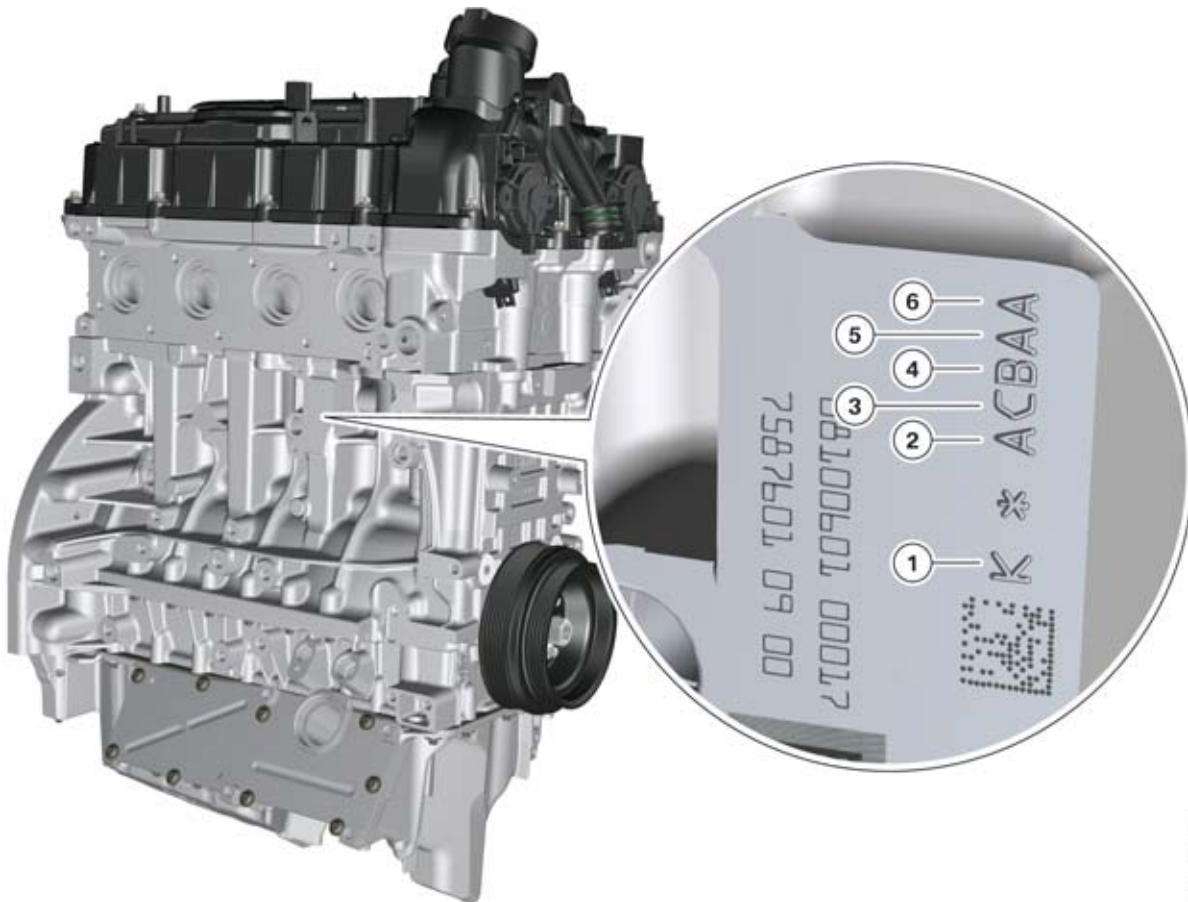

TO10-1522

N20 engine, bearing identification, crankcase

Index	Explanation
1	“K” stands for clutch end
2	Bearing 5
3	Bearing 4
4	Bearing 3
5	Bearing 2
6	Bearing 1

The “K” designation in position (1) stands for clutch end (German: Kupplungsseite). Thus the first code digit (2) is the ID code for bearing 5 in the crankcase. The second code digit (3) stands for bearing 4, etc.

The following is an example of how to calculate the correct crankshaft main and rod bearings using the stamping codes.

N20 Engine

2. Engine Components



Bearing position	1	2	3	4	5
Crankcase code	A	A	B	C	A
Upper bearing color	Yellow	Yellow	Blue	Red	Yellow
Crankshaft code	2	1	2	1	1
Lower bearing (cap) color	Blue	Yellow	Blue	Yellow	Yellow



Upper	Lower	Bearing color	Bearing play/thickness	Bearing	Bearing size
A	1	Yellow	Large/Thin	1 2 to 5	49.978 – 49.984 49.999 – 49.993
B	2	Blue	Medium/Medium	1 2 to 5	49.972 – 49.977 49.987 – 49.992
C	3	Red	Small/Thick	1 2 to 5	49.965 – 49.971 49.980 – 49.986

Example of the crankshaft bearing selection procedure.



Bearing position	1	2	3	4
Crankshaft connecting rod code	r	r	r	r
Connecting rod side big-end bearing color	Yellow	Yellow	Yellow	Yellow
Connecting rod cap side big-end bearing color	Red	Red	Red	Red

Bearing class/code	Bearing color	Bearing play/thickness	Bearing size
b	Violet	Large/Thin	49.9730 – 49.9834
	Blue		
r	Yellow	Small/Thick	49.9835 – 49.9930
	Red		

Example of the connecting rod bearing selection procedure.

N20 Engine

2. Engine Components



Note: This training material is intended for classroom instruction only. It is not meant to replace currently available repair instructions. Always refer to the most current version of repair instructions, technical data and torque specifications. Refer to the latest version of ISTA.

Pin offset

Pistons always require a running clearance. The running clearance means that there is always a certain degree of lateral movement (piston slap) as the piston changes direction from up-stroke to down-stroke. The greater the force acting on the piston and the greater the running clearance, the greater the piston slap.

Pin offset involves advancing the time when the piston changes between the compression and power stroke to the lower pressure range before top dead center. This results in a reduction of noise and friction.

Pin offset refers to the displacement of the wrist pin axis from the cylinder center line of the piston. A positive offset indicates offset to the major thrust face, a negative offset denotes offset to the minor thrust face. The major thrust face refers to that side of the piston on which the piston rests in the combustion stroke on its way to bottom dead center (see arrow of III). Minor thrust is the piston's thrust against the opposite cylinder wall during the compression stroke (see arrow of I).

The following graphic shows a conventional crankshaft drive without pin and crankshaft offset.

N20 Engine

2. Engine Components

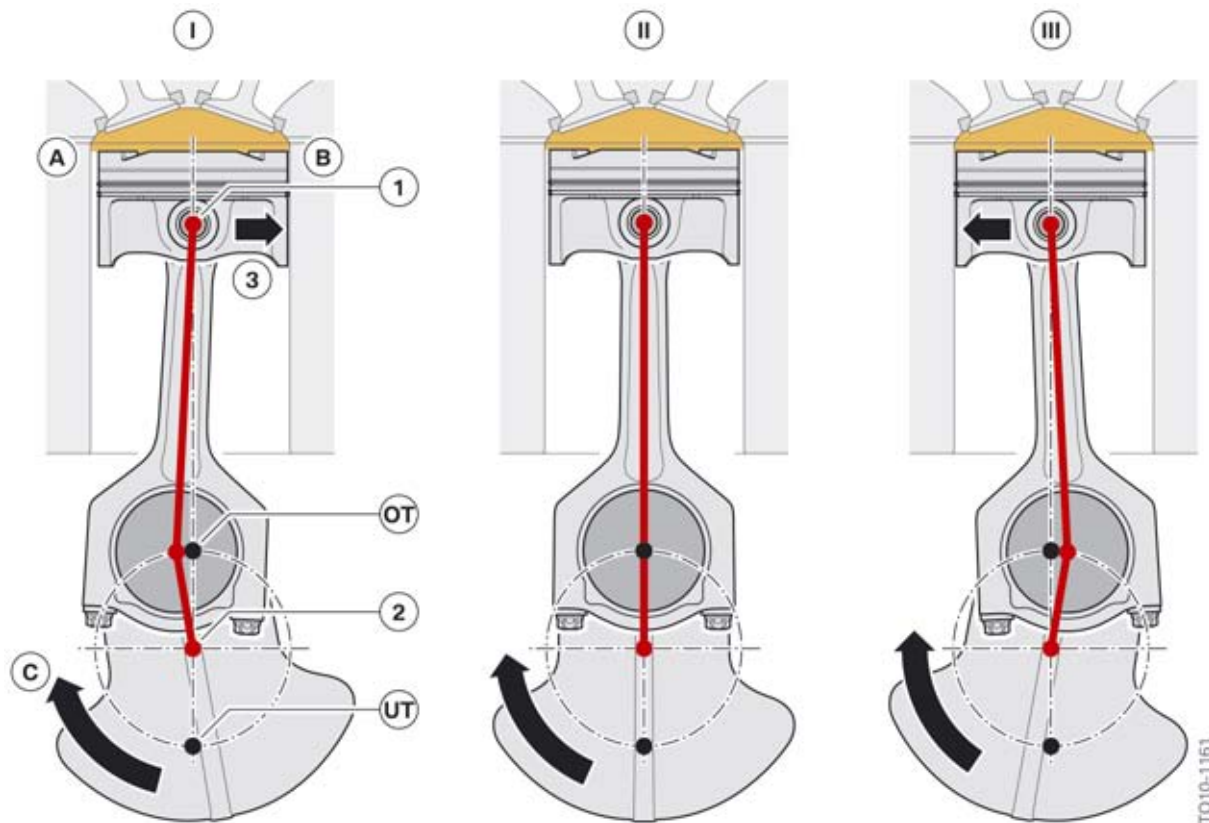

Conventional crankshaft drive

Index	Explanation
I	Piston position and crankshaft position shortly before top dead center (TDC)
II	Piston position and crankshaft position at top dead center
III	Piston position and crankshaft position after top dead center
A	Major thrust face
B	Minor thrust face
C	Direction of engine rotation
1	Wrist pin
2	Center of crankshaft rotation
3	Thrust force

As the graphic shows, in a conventional crankshaft drive assembly the wrist pin boss, the connecting rod and the center of crankshaft rotation are in line at top dead center (TDC). Because of this arrangement, the piston is forced against the minor thrust face (B) during the up-stroke. At TDC the forces are compensated because the pressure on the minor thrust face decreases as the crankshaft rotates away from TDC and the piston tilts towards the major thrust face (A). Because there is already high pressure at TDC, this abrupt change of face causes a noise which is referred to as piston slap.

Pin offset can be effected towards the major thrust face (positive) and also towards the minor thrust side (negative). Major-thrust-face pin offset is also referred to as noise offset.

N20 Engine

2. Engine Components

Minor-thrust-face pin offset is also referred to as thermal offset. In this position the sealing effect of the piston rings is improved.

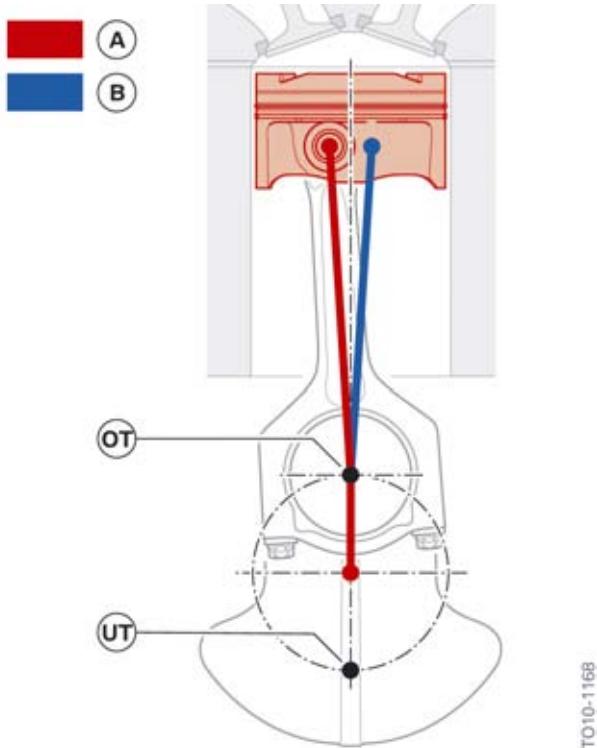

Pin offset

Index	Explanation
A	Major-thrust-face pin offset (positive)
B	Minor-thrust face pin offset (negative)
OT	Top dead center
UT	Bottom dead center

Because the noise can be heard during the change of faces, technical measures are used to shift this change of faces as far as possible to a range (piston position) in which the acting forces are lower. This is done in current BMW engines by offsetting the wrist pin towards the major thrust face.

The offset is about 0.3 - 0.8 mm in conventional engines and is therefore virtually imperceptible to the eye. This is also the reason why the pistons have a directional marking at the top. Incorrect installation may result in extreme noise similar to that generated by piston damage.

N20 Engine

2. Engine Components

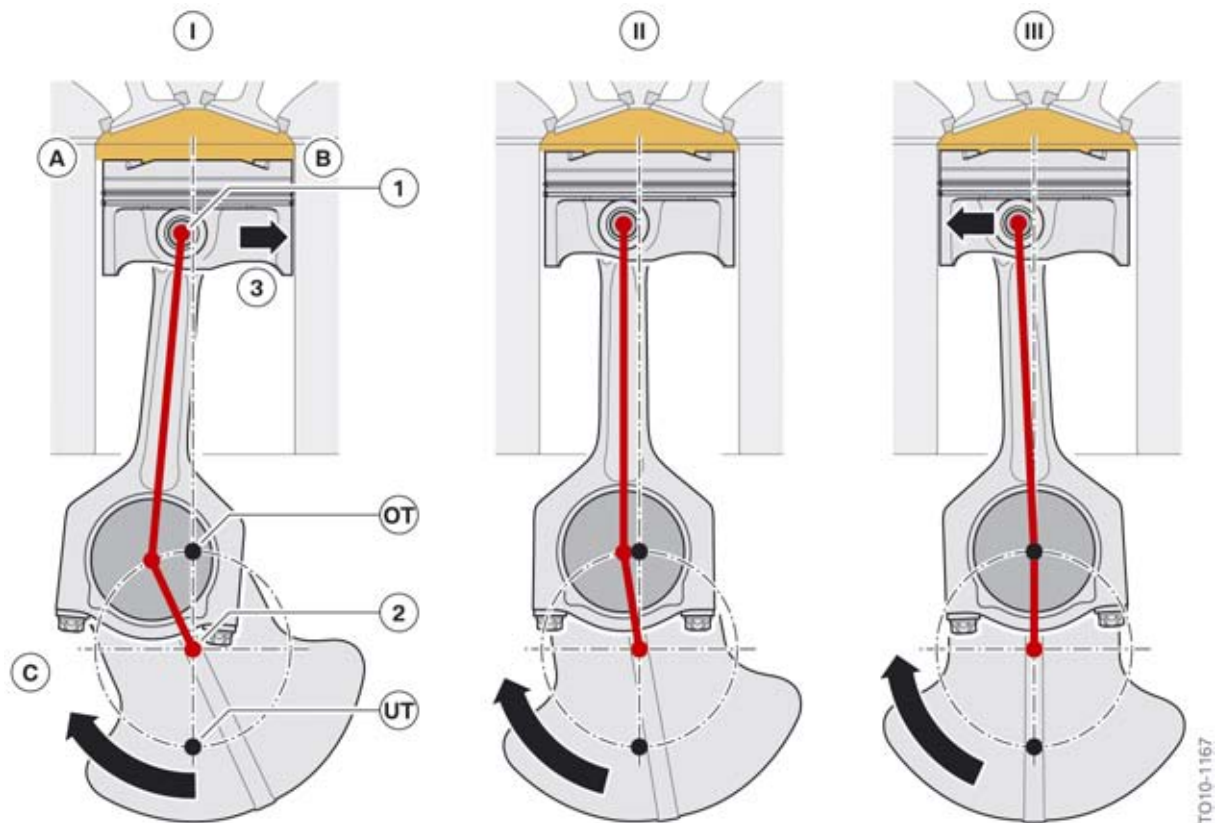

Piston rocking in an engine with pin offset

Index	Explanation
I	Piston position and crankshaft position before top dead center
II	Piston position and crankshaft position shortly before top dead center, with perpendicular connecting rod
III	Piston position and crankshaft position at top dead center
A	Major thrust face
B	Minor thrust face
C	Direction of engine rotation
1	Wrist pin
2	Center of crankshaft rotation
3	Thrust force

The piston rests against the minor thrust face during the up-stroke. A neutral piston position is already achieved before TDC by offsetting the wrist pin. This is the case when the center lines of the cylinder and of the big and small connecting rod eyes are parallel to each other. Already before TDC the piston changes from the minor thrust face to the major thrust face. In this phase the force on the piston is still low. Due to the off-center support of the piston, the force acting on the piston from above has a higher lever arm on the one face than on the other. In this way, the piston is already tilted during the up-

N20 Engine

2. Engine Components

stroke, resulting in contact with the major thrust face at the upper edge. In its subsequent movement the piston again travels straight ahead, so that the piston rests completely on the major thrust face. The change of faces is much quieter than in a conventional crankshaft drive.

The downside of pin offset is that there is a slight increase in friction on the major thrust face. This minor downside, however, is made up for by the reduced noise.

Crankshaft offset

A crankcase with crankshaft offset is used for the first time by BMW.

Crankshaft offset denotes the offset of the crankshaft axis from the cylinder center line. This offset can effect on both the major thrust face and the minor thrust face. A positive offset denotes offset to the major thrust face, a negative offset denotes offset to the minor thrust face.

Crankshaft offset can basically be effected in both directions, but up to now only the variation in the positive direction (A) has been used.

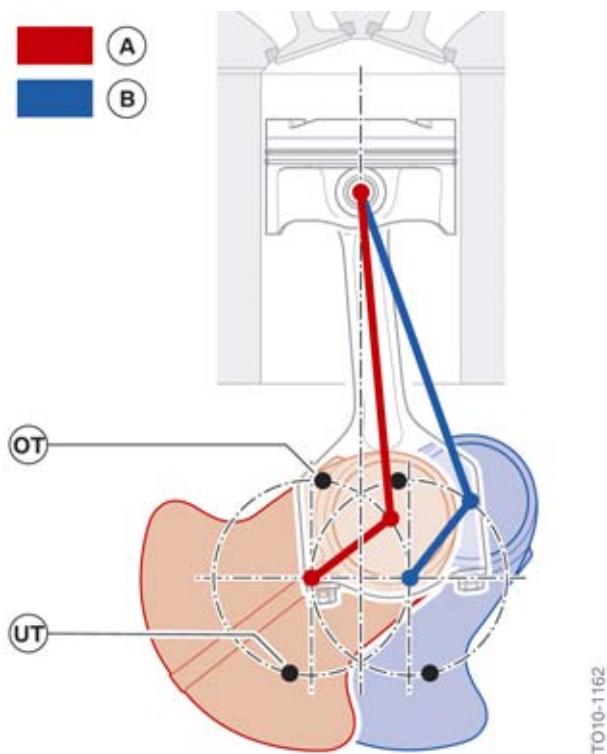

Crankshaft offset

Index	Explanation
A	Positive offset
B	Negative offset
OT	Top dead center
UT	Bottom dead center

N20 Engine

2. Engine Components

The following graphic clearly shows that positive crankshaft offset, when compared with positive pin offset, has an opposed effect on piston rocking. Thus piston rocking occurs much later and in the range of a high cylinder pressure.

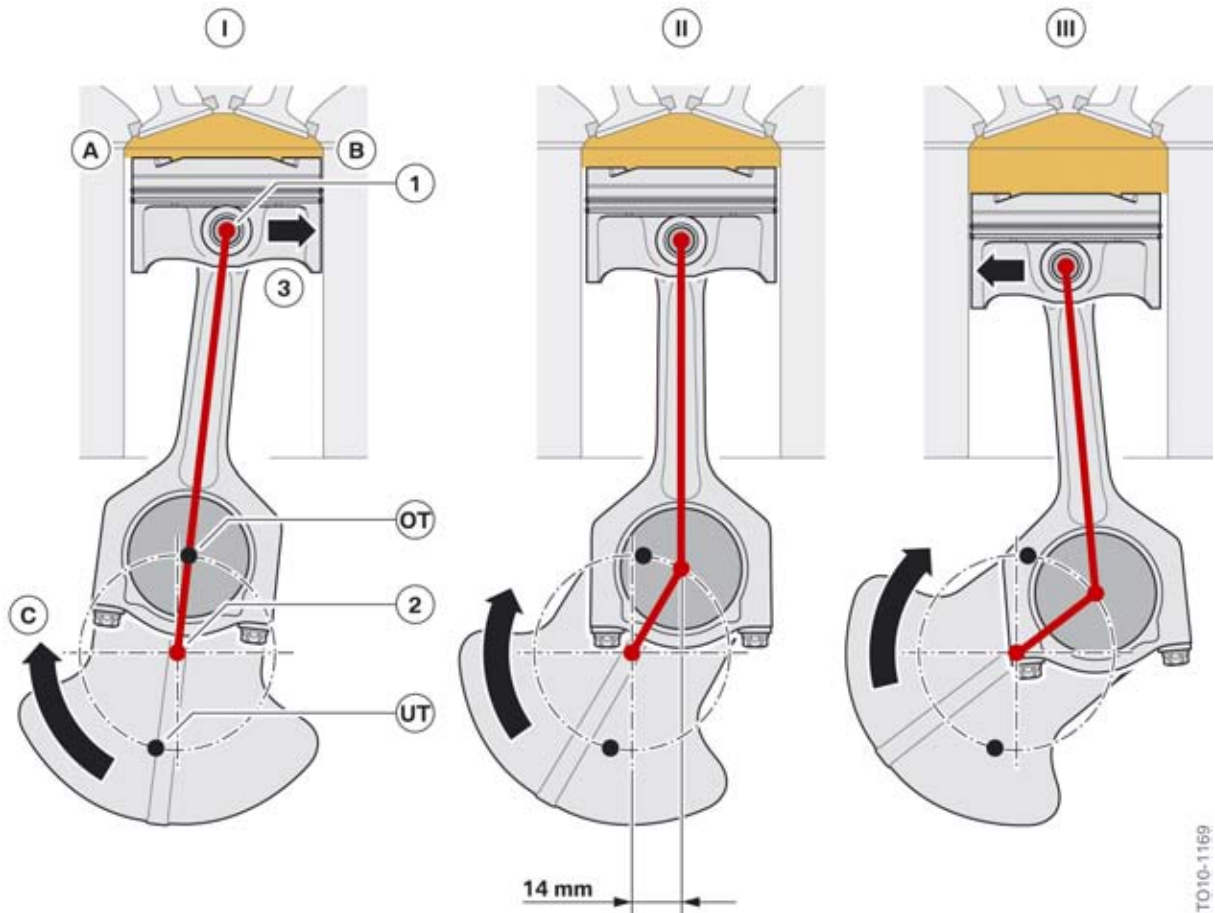

Piston rocking in an engine with crankshaft offset

Index	Explanation
I	Piston position and crankshaft position shortly after top dead center
II	Piston position and crankshaft position with perpendicular connecting rod
III	Piston position and crankshaft position after piston rocking
A	Major thrust face
B	Minor thrust face
C	Direction of engine rotation
1	Wrist pin
2	Crankshaft
OT	Top dead center
UT	Bottom dead center

N20 Engine

2. Engine Components

The top and bottom dead centers are also shifted by the crankshaft offset. The top and bottom dead centers are achieved in the extended and overlap positions respectively. The connecting rod and the crankshaft point geometrically in the same direction.

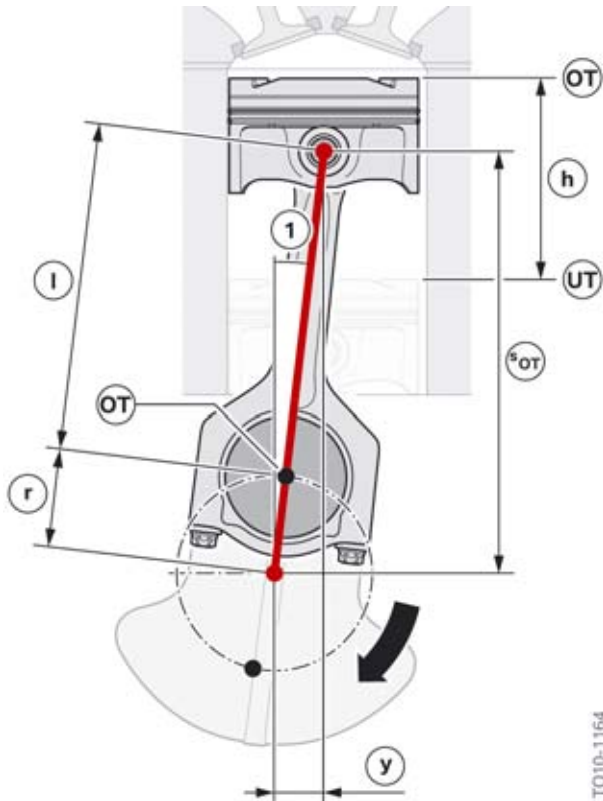

TO10-1164

TDC position in an engine with crankshaft offset

Index	Explanation
OT	Top dead center
UT	Bottom dead center
l	Connecting rod length
r	Crank throw
y	Crankshaft offset
s _{OT}	Distance TDC
h	Piston stroke
1	Angle in TDC position α TDC

Bottom dead center likewise changes its position and runs to a crank angle of over 180°.

N20 Engine

2. Engine Components

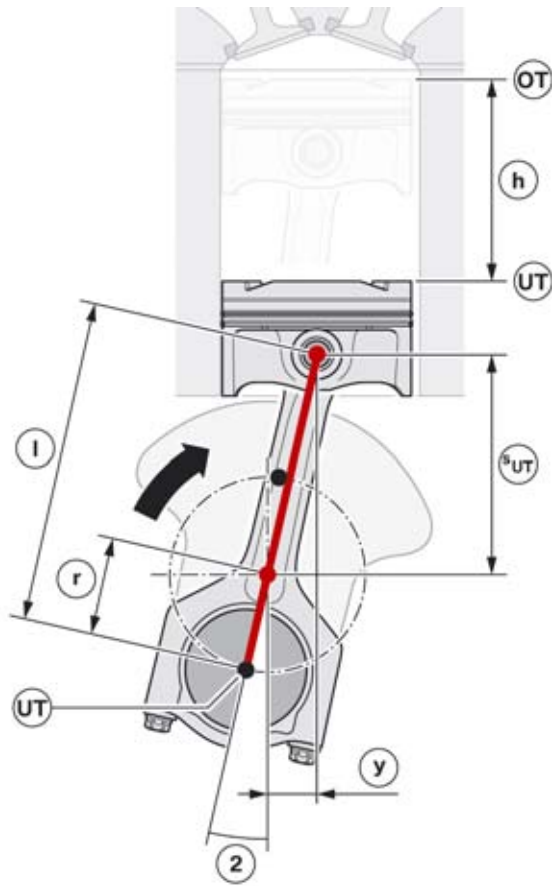

TO10-1165

BDC position in an engine with crankshaft offset

Index	Explanation
OT	Top dead center
UT	Bottom dead center
l	Connecting rod length
r	Crank throw
y	Crankshaft offset
s_{UT}	Distance BDC
h	Piston stroke
2	Angle in BDC position α BDC

A combination of positive crankshaft offset and negative pin offset is used in the N20 engine.

Both negative and positive pin offset affect the piston rocking behavior. In response to the distribution of forces during piston rocking, this occurs later and more quietly.

N20 Engine

2. Engine Components

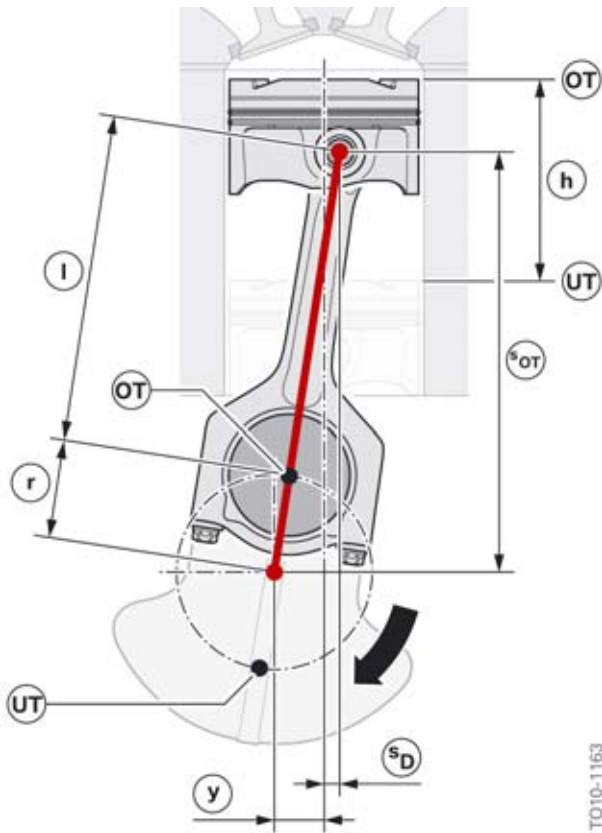

Combination of crankshaft and pin offset

TO10-1163

Index	Explanation
OT	Top dead center
UT	Bottom dead center
l	Connecting rod length
r	Crank throw
y	Crankshaft offset
s_D	Pin offset
s_{OT}	Distance TDC
h	Piston stroke

The N20 engine features connecting rods 144.35 mm long, with a crank throw of 44.8 mm. Crankshaft offset is +14 mm, offset of the wrist pin is -0.3 mm.

N20 Engine

2. Engine Components

Data	Value
Stroke	90.09 mm
TDC	+ 4.336°
BDC	+ 188.259°
Induction cycle angle and power cycle angle	183.923°
Compression cycle angle and exhaust cycle angle	176.077°

Advantages

In an engine with crankshaft offset, the connecting rod in the power stroke is in a roughly perpendicular position (see the graphic on the right) in contrast to an engine without crankshaft offset (see the graphic on the left). This design significantly reduces the thrust force (5) and the friction of the piston on the cylinder wall which result is increased efficiency. The crankshaft offset in the N20 engine is thus considered one more BMW EfficientDynamics measure.

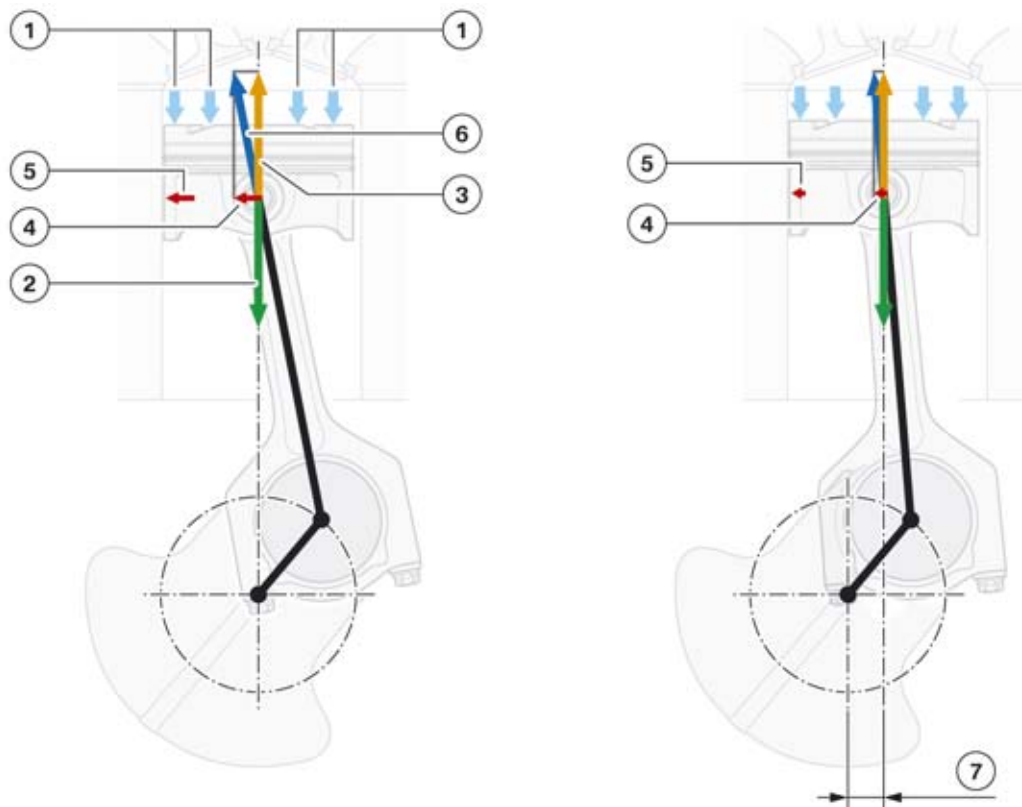

System diagram of acting forces, left: normal engine, right: engine with crankshaft offset

TO10-1405

N20 Engine

2. Engine Components

Index	Explanation
1	Pressure force from combustion
2	Normal piston force
3	Opposite piston force
4	Lateral piston force
5	Thrust force
6	Resulting force
7	Crankshaft offset

2.2.2. Connecting rod

Connecting rod

The connecting rod of the N20 engine has an inside diameter of 144.35 mm. As with the N55 the N20 uses a specially formed hole in the small end of the connecting rod. This formed hole is machined wider on the lower edges of the wrist pin bushing/bore. This design evenly distributes the force acting on the wrist pin over the entire surface of the rod bushing and reduces the load at the edges, as the piston is forced downward on the power stroke.

N20 Engine

2. Engine Components



N20 engine, connecting rod

2.2.3. Piston with piston rings

A full slipper skirt piston manufactured by the company FM is used. The piston diameter is 84 mm. The first piston ring is a steel-nitrided plain compression ring. The second piston ring is a stepped compression ring. The oil scraper ring is a steel band ring with a spring, which is also known as an MF system ring.

As previously discussed the wrist pin axis has a negative offset to the minor thrust face.

An installation position arrow is stamped on the piston. This arrow always points to the installation of the piston in a longitudinal direction facing the timing chain. It is necessary to install the piston in the correct position, since the asymmetric valve reliefs on the intake and exhaust sides will result in valve and cylinder wall damage.

N20 Engine

2. Engine Components



TO10-1524

N20 engine, piston

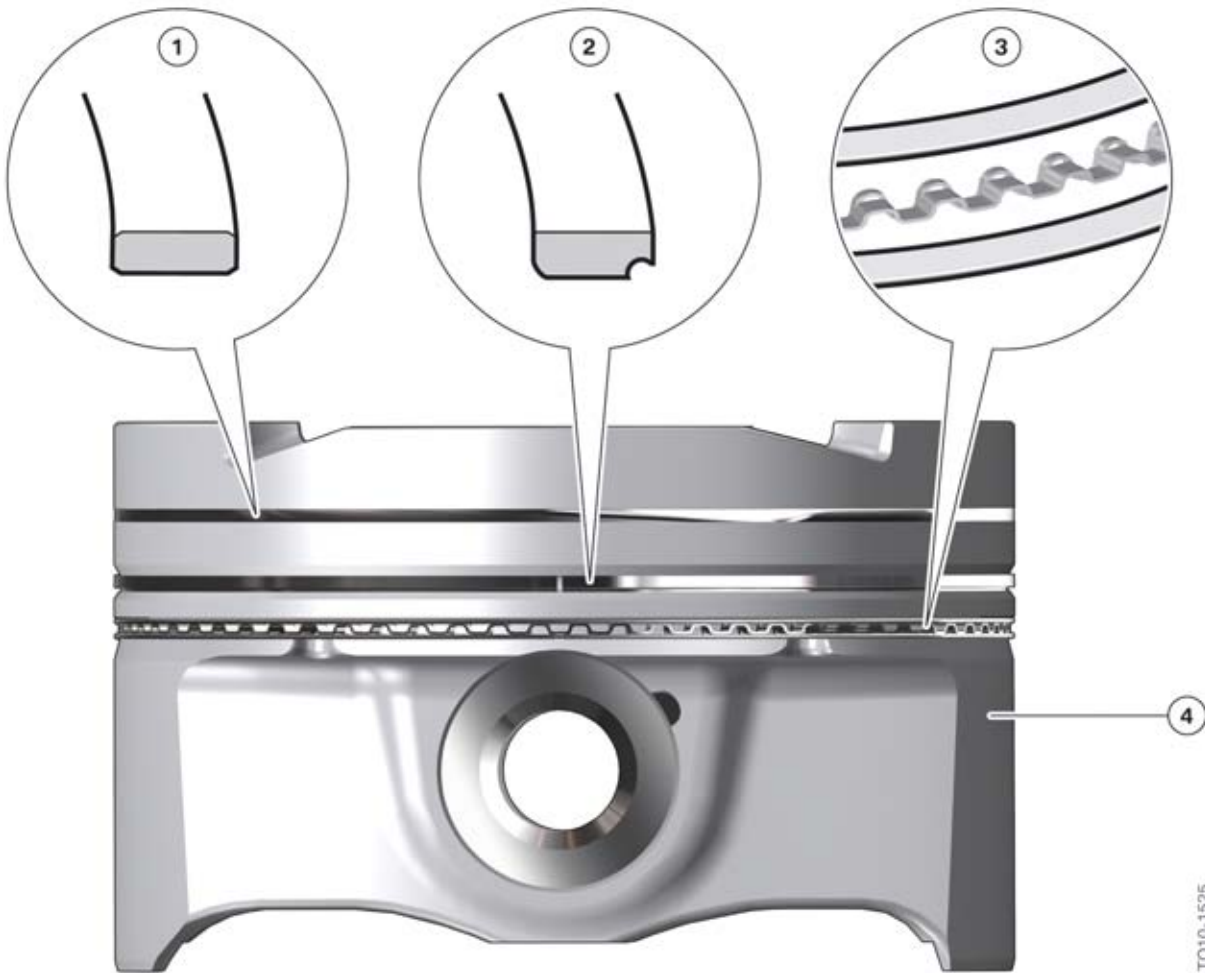

TO10-1525

N20 engine, piston rings

N20 Engine

2. Engine Components

Index	Explanation
1	Plain compression ring
2	Stepped compression ring
3	MF system ring
4	Piston

2.3. Camshaft drive

The camshaft drive design is similar to previous engines. The oil pump is gear driven via the counterbalance shafts. To ensure that the counterbalance shafts are correctly positioned in relation to the crankshaft, a secondary chain drive is used which is also equipped with a chain tensioner. Both chains have tooth-type design.

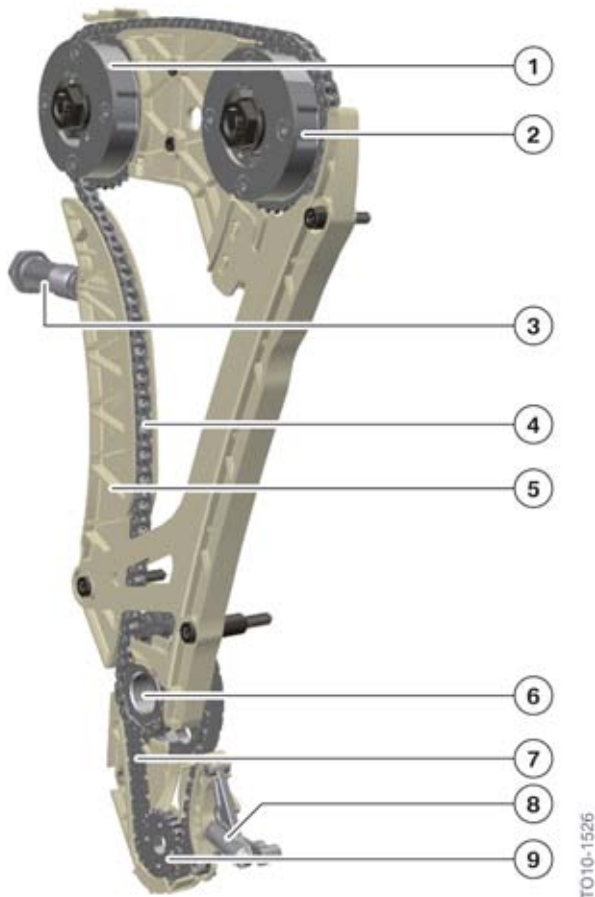

N20 engine, camshaft drive

TO10-1526

N20 Engine

2. Engine Components

Index	Explanation
1	Exhaust VANOS
2	Intake VANOS
3	Chain tensioner
4	Primary chain
5	Tensioning rail
6	Sprocket, driven by crankshaft
7	Secondary chain (tooth-type chain)
8	Chain tensioner
9	Sprocket for counterbalance shaft and oil pump drive

2.4. Counterbalance shafts

The purpose of the counterbalance shafts is to improve the engine's smooth running and acoustic performance. This is achieved using two counter-rotating shafts which are fitted with balance weights.

The counterbalance shafts are driven by the crankshaft via a tooth-type chain. The tooth-type chain requires the use of special gears on the crankshaft and the counterbalance shafts. The tooth-type chain optimizes the rolling of the drive chain on the sprockets, thereby reducing noise.

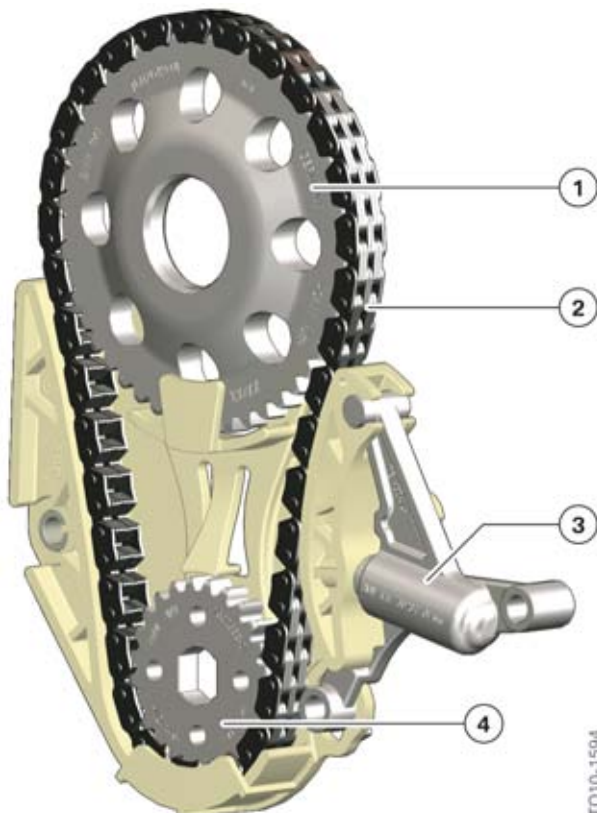

N20 engine, counterbalance shaft and oil pump drive

N20 Engine

2. Engine Components

Index	Explanation
1	Crankshaft sprocket
2	Tooth-type chain
3	Chain tensioner
4	Counterbalance shaft sprocket

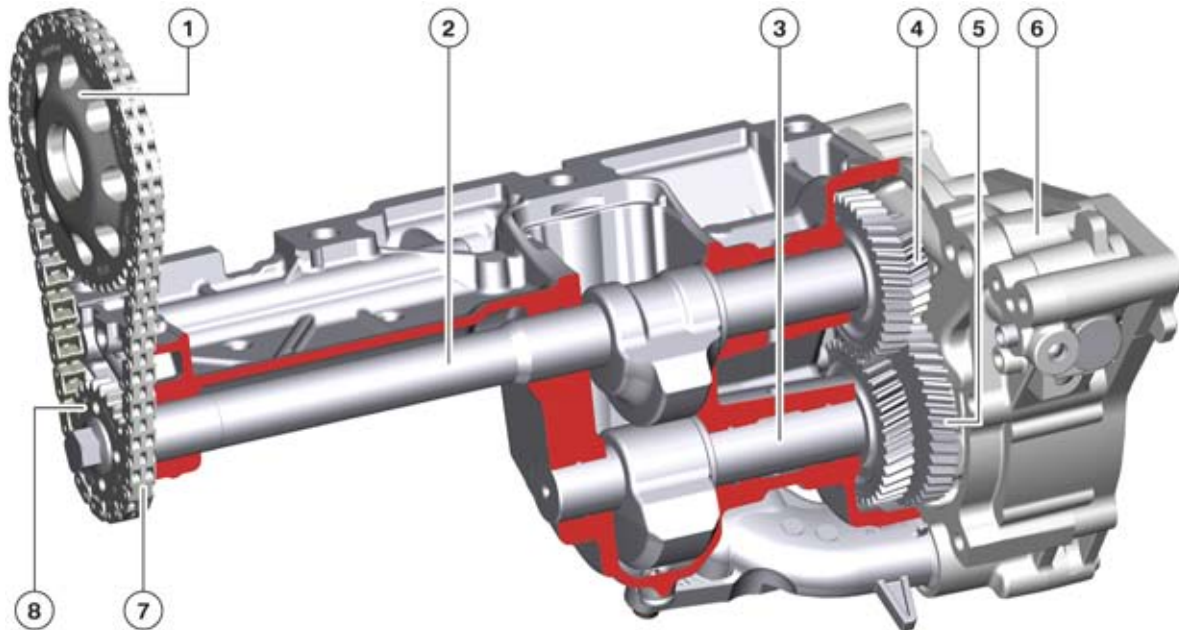

N20 engine, counterbalance shafts

Index	Explanation
1	Sprocket on crankshaft
2	Upper counterbalance shaft
3	Lower counterbalance shaft
4	Gear, upper counterbalance shaft
5	Gear, oil pump
6	Oil pump
7	Tooth-type chain, counterbalance shaft and oil pump drive
8	Counterbalance shaft sprocket

N20 Engine

2. Engine Components

Before removing and installing the counterbalance drive sprocket the lower counterbalance shaft must be secured with a 4.5 mm thick alignment pin (special tool # 2 212 825) to securely position the counterbalance shafts with the crankshaft.

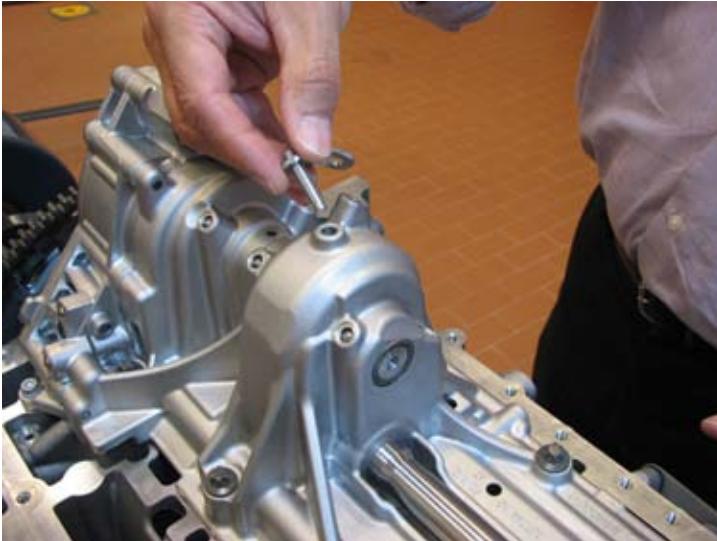

Counterbalance shaft alignment pin tool 2 212 825

A seal plug which is inserted in the locating hole must be removed for this purpose. This seal plug prevents oil from flowing into the counterbalance shaft chamber during operation, a situation which would cause oil foaming. It is thus imperative that this seal plug be reinstalled during final assembly. The excess oil in the chamber is carried along by the rotation of the balance weights and returned via a discharge opening to the oil sump.



Counterbalance shaft seal plug



Positioning of the counterbalance shafts in alignment is necessary to ensure smooth, fault-free engine operation. Please refer to the repair instructions for more information.

N20 Engine

2. Engine Components

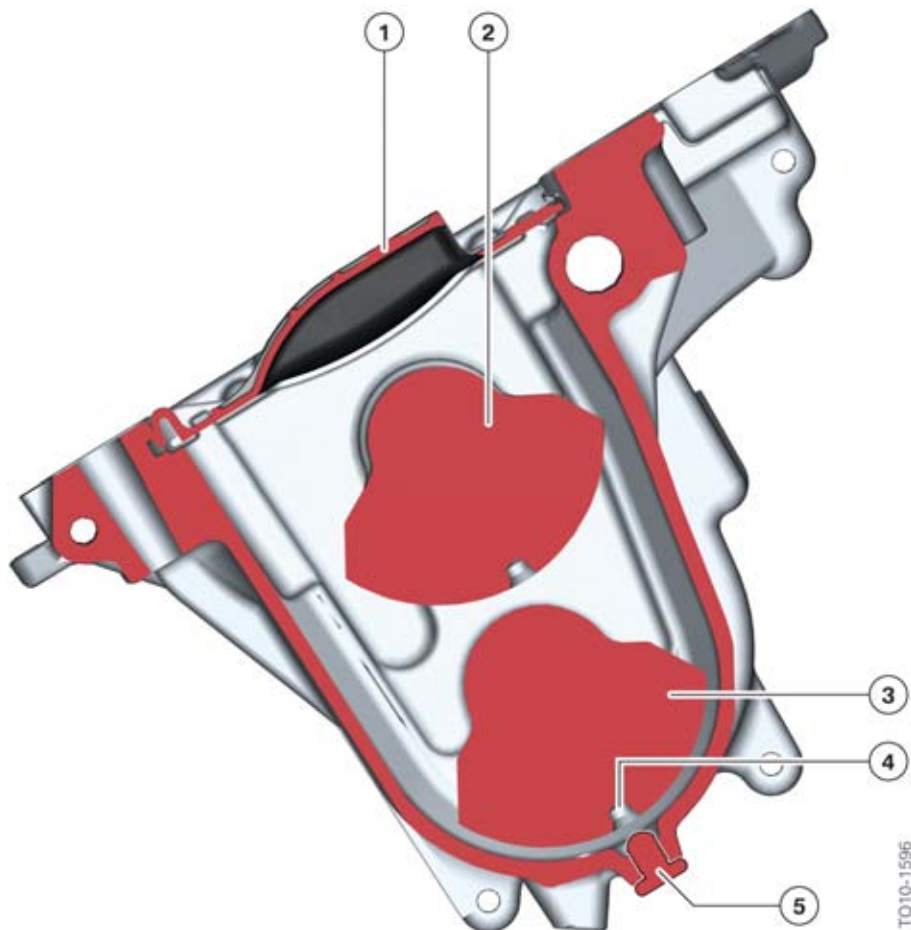

N20 engine, cutaway view of counterbalance shafts

Index	Explanation
1	Discharge opening
2	Upper counterbalance shaft
3	Lower counterbalance shaft
4	Alignment pin, lower counterbalance shaft
5	Seal plug

N20 Engine

2. Engine Components

2.5. Valve gear

2.5.1. Design

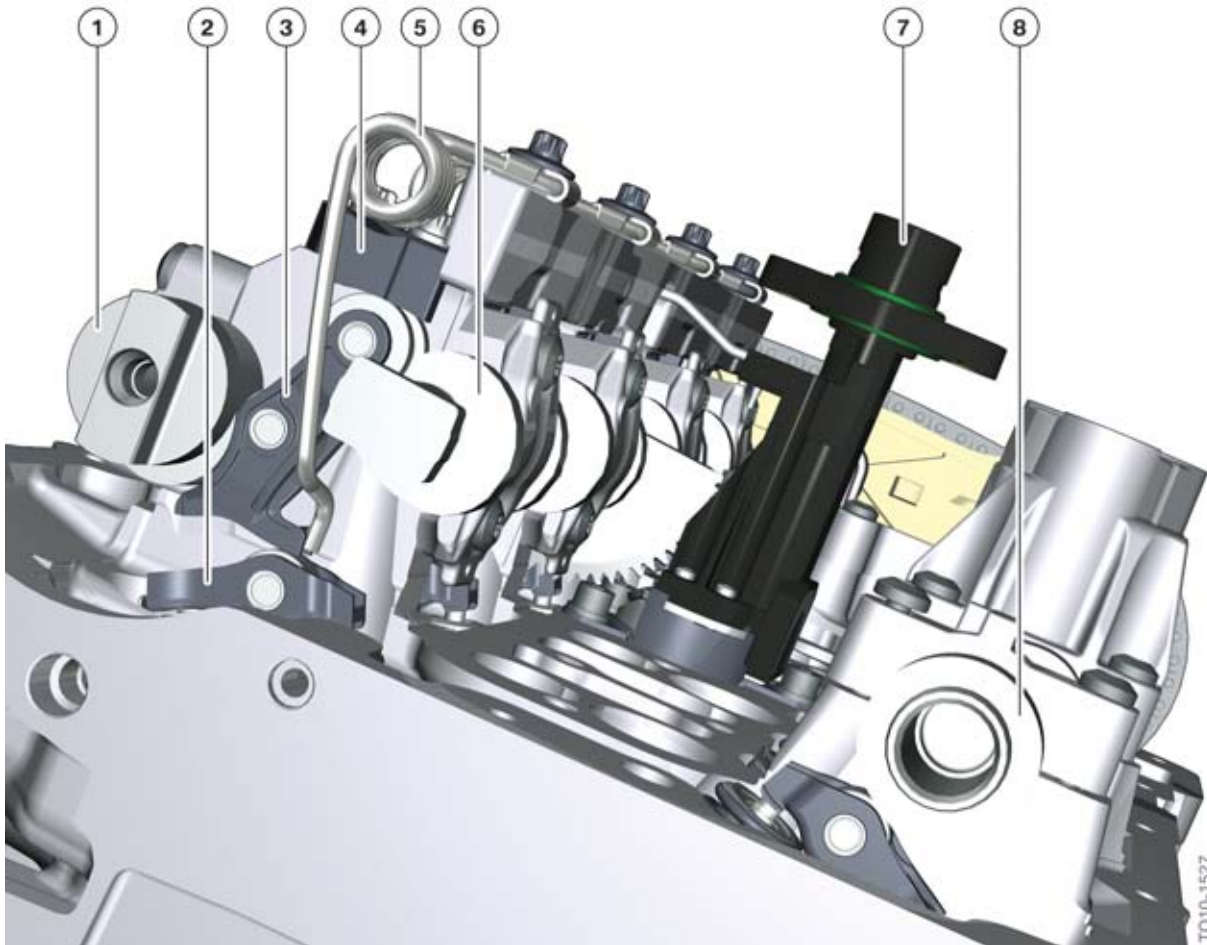

N20 engine, valve gear

Index	Explanation
1	Intake camshaft
2	Roller cam follower
3	Intermediate lever
4	Guide block
5	Torsion spring
6	Eccentric shaft
7	Valvetronic servomotor
8	Exhaust camshaft

N20 Engine

2. Engine Components

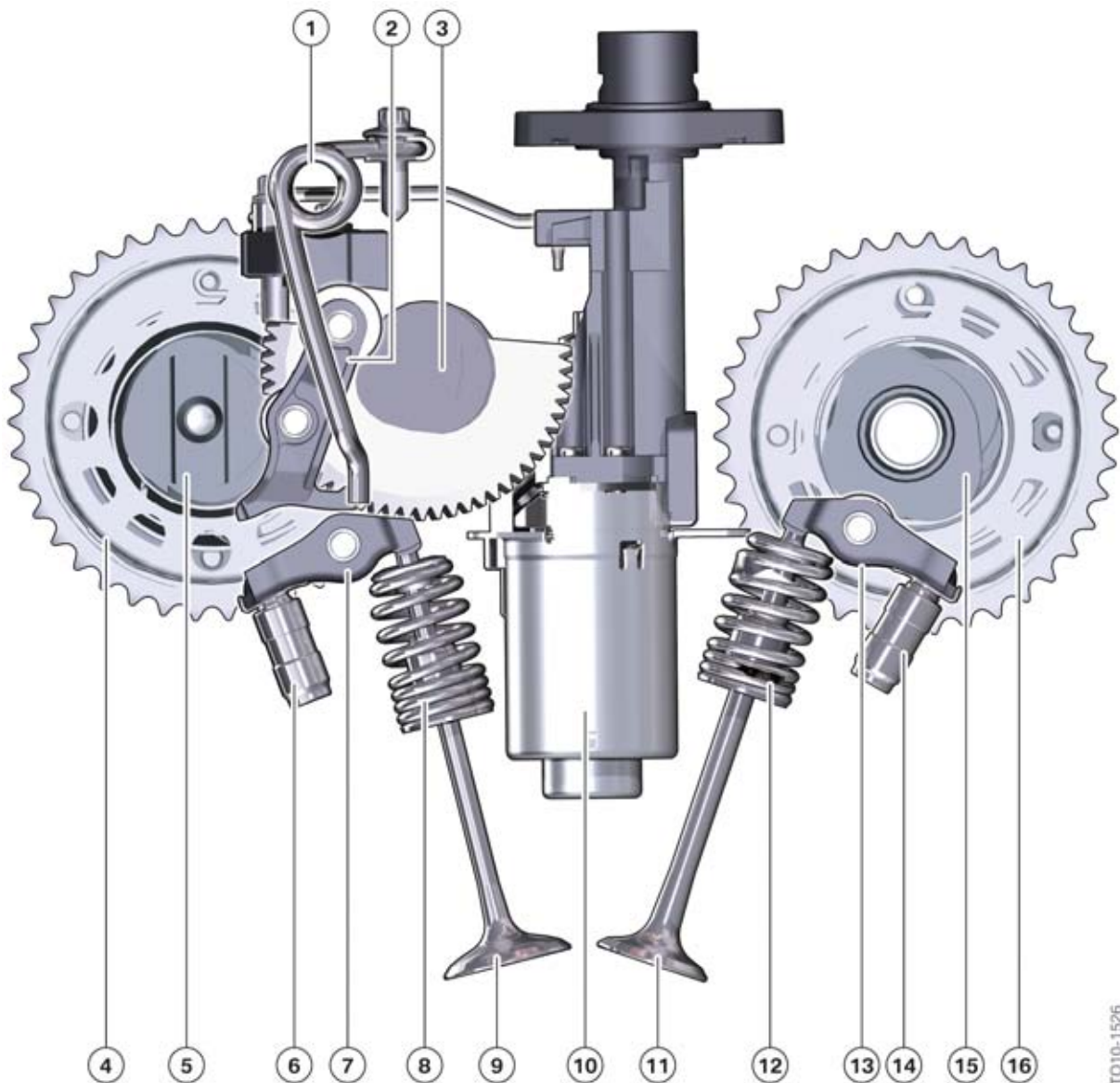

N20 engine, valve gear

TO10-1526

Index	Explanation
1	Torsion spring
2	Intermediate lever
3	Eccentric shaft
4	VANOS unit, intake
5	Intake camshaft
6	HVCC element, intake
7	Roller cam follower, intake
8	Valve spring, intake valve

N20 Engine

2. Engine Components

Index	Explanation
9	Intake valve
10	Valvetronic servomotor
11	Exhaust valve
12	Valve spring, exhaust valve
13	Roller cam follower, exhaust
14	HVCC element, exhaust
15	Exhaust camshaft
16	VANOS unit, exhaust

The roller cam followers on the intake side are made from sheet metal and subdivided into five classes, Class “1” to Class “5”. The intermediate levers are now also made from sheet metal and are subdivided into six classes, Class “00” to Class “05”.

Camshafts

The N20 engine is fitted with the assembled camshafts already known from the M73 engine. All the components are shrink-fitted onto the shaft. The timing of the camshafts requires new special tool, # 2 212 831. Please refer to the repair instructions for proper timing procedures.

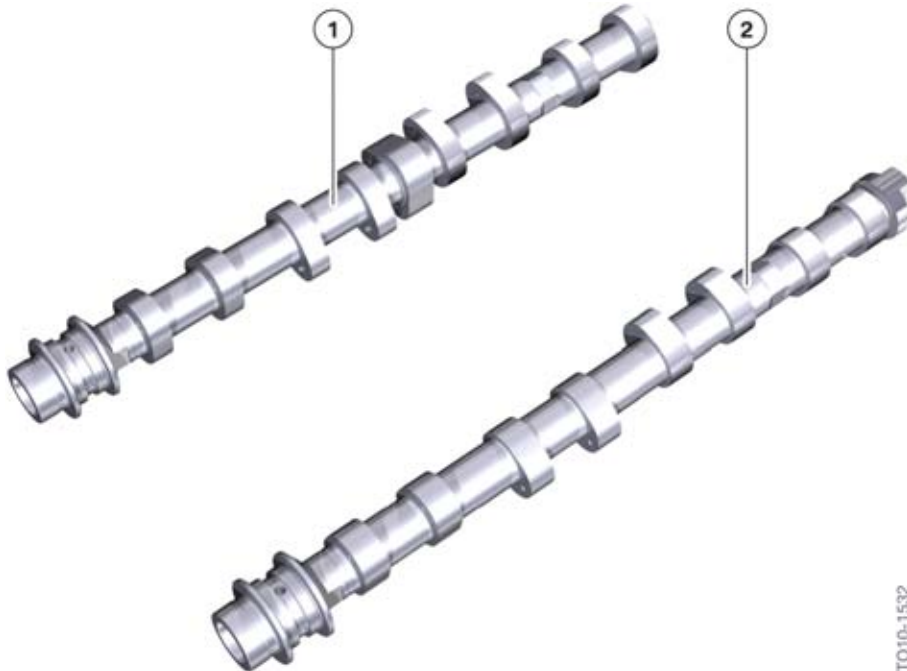

N20 engine, assembled camshafts

TO10-1532

Index	Explanation
1	Exhaust camshaft
2	Intake camshaft

N20 Engine

2. Engine Components

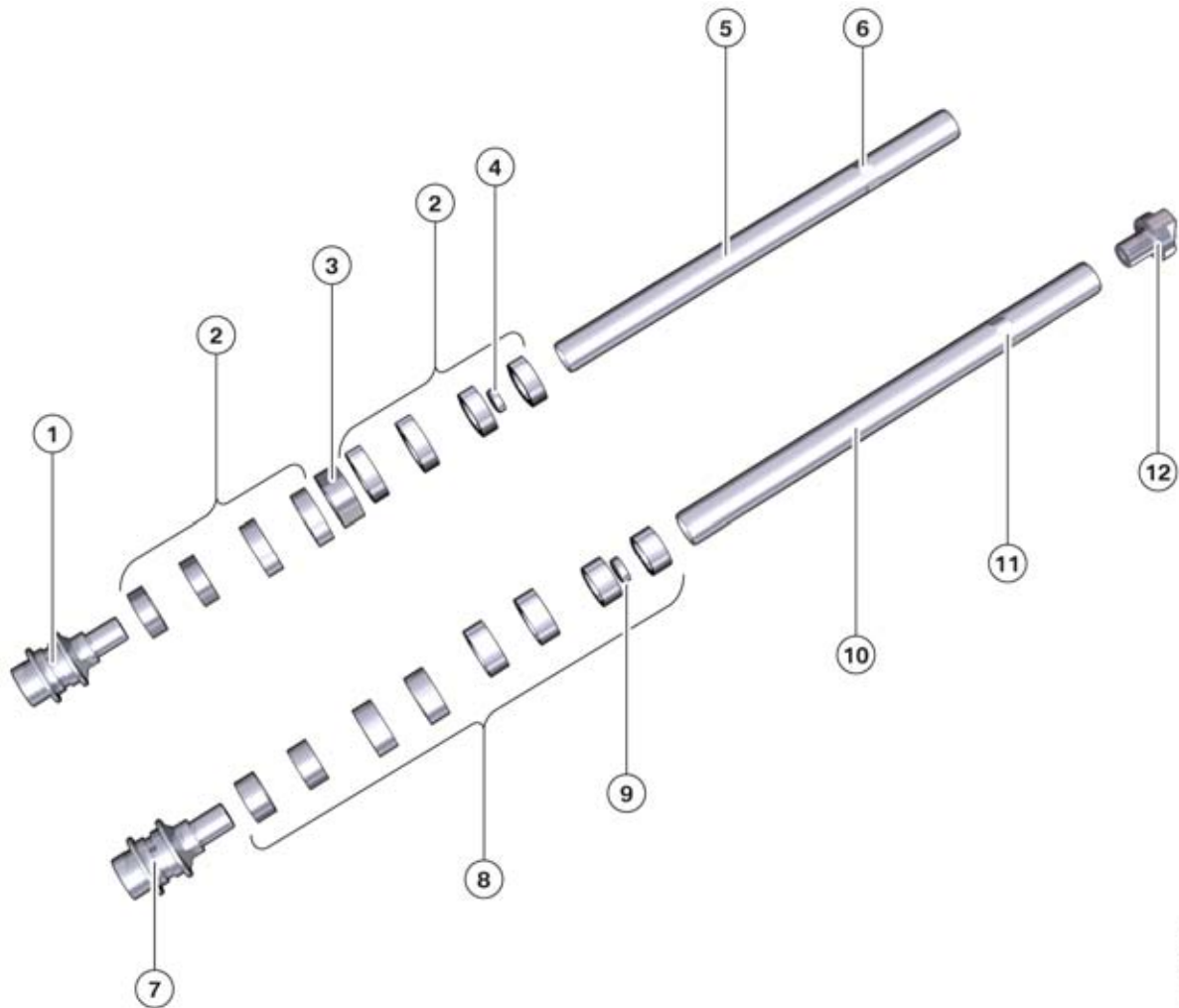

N20 engine, assembled camshafts

TO10-1531

Index	Explanation
1	Flange for VANOS unit, exhaust
2	Cam
3	Cam for high-pressure pump
4	Sealing cap
5	Pipe
6	Hexagon head
7	Flange for VANOS unit, intake
8	Cam

N20 Engine

2. Engine Components

Index	Explanation
9	Sealing cap
10	Pipe
11	Hexagon head
12	Vacuum pump drive

Valve timing

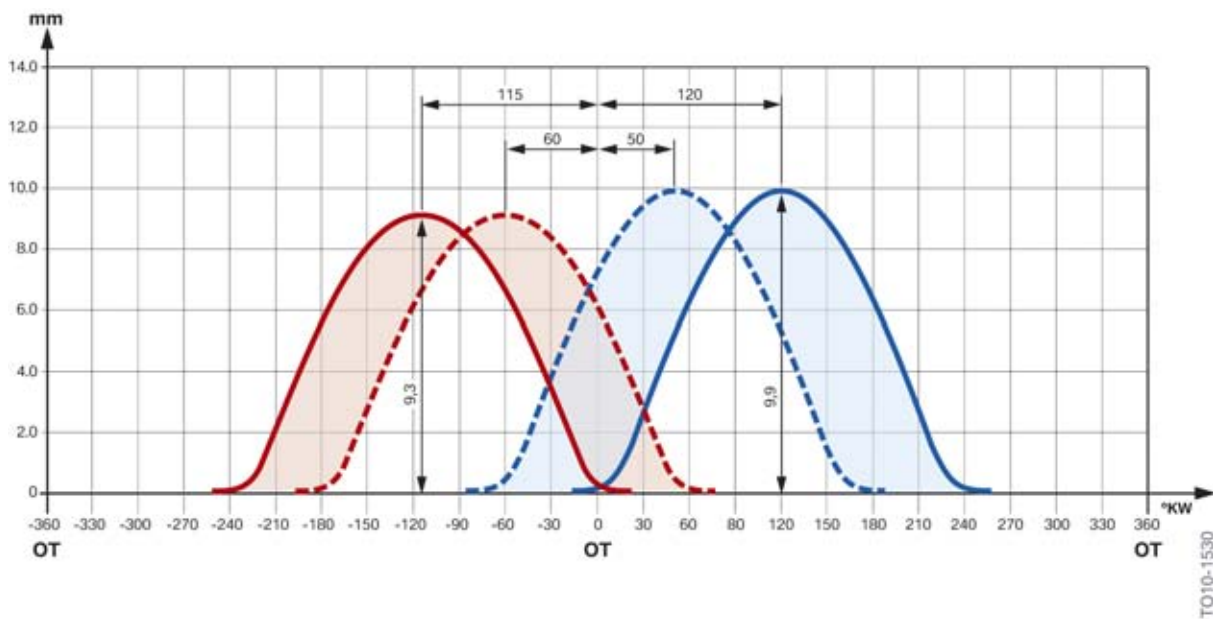

N20 engine, valve timing diagram

		N55B30M0	N20B2000
Intake valve dia./stem dia.	[mm]	32/5	32/5
Exhaust valve dia./stem dia.	[mm]	28/6	28/6
Maximum valve lift, intake/exhaust valve	[mm]	9.9/9.7	9.9/9.3
VANOS adjustment range, intake	[°CA]	70	70
VANOS adjustment range, exhaust	[°CA]	55	55
Spread, intake camshaft	[°CA]	120 – 50	120 – 50
Spread, exhaust camshaft	[°CA]	115 – 60	115 – 60
Opening period, intake camshaft	[°CA]	258	258
Opening period, exhaust camshaft	[°CA]	261	252

N20 Engine

2. Engine Components

Intake and exhaust valves

The intake and exhaust valves are carryover parts from the N55 engine. The intake valve has a stem diameter of 5 mm. The exhaust valve has a stem diameter of 6 mm, because it is hollow and sodium filled. The exhaust valve seats are made from hardened material and the intake valve seats are induction-hardened.

Valve springs

The valve springs used for the intake and exhaust valves are different. The intake valve springs have already been used in the N52, N52TU and N55 engines. The exhaust valve springs are familiar from the N51, N52, N52TU, N54 and N55 engines.

2.5.2. Valvetronic



The Valvetronic comprises fully variable valve lift control and variable camshaft control (double VANOS), which makes the closing time of the intake valve freely adjustable.

Valve lift control is performed on the intake side, while camshaft control is performed on both the intake and exhaust sides.

Throttle-free load control is only possible if:

- the lift of the intake valve
- and camshaft adjustment of the intake and exhaust camshafts are variably controllable.

Result:

The opening and closing times and thus the opening period and the lift of the intake valve are freely adjustable.

VANOS

The VANOS system has been modified. This modification now provides for even faster VANOS unit setting speeds. The modification has also further reduced system failure. The following comparison of the VANOS systems of N55 and N20 engines shows that fewer oil passages are necessary.

N20 Engine

2. Engine Components

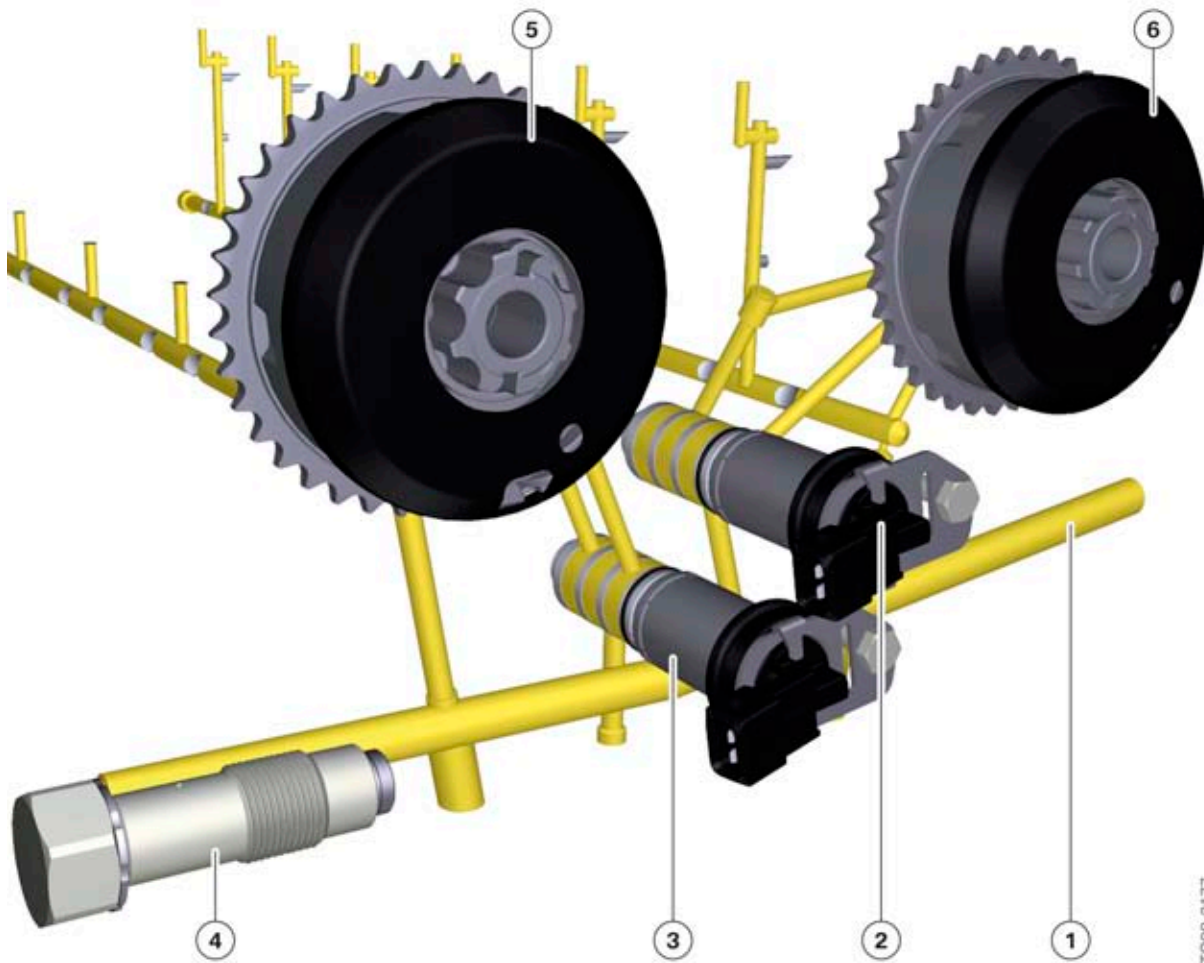

TO08-2177

N55 engine, VANOS with oil supply

Index	Explanation
1	Main oil passage
2	VANOS solenoid valve, intake side
3	VANOS solenoid valve, exhaust side
4	Chain tensioner
5	VANOS unit, exhaust side
6	VANOS unit, intake side

N20 Engine

2. Engine Components

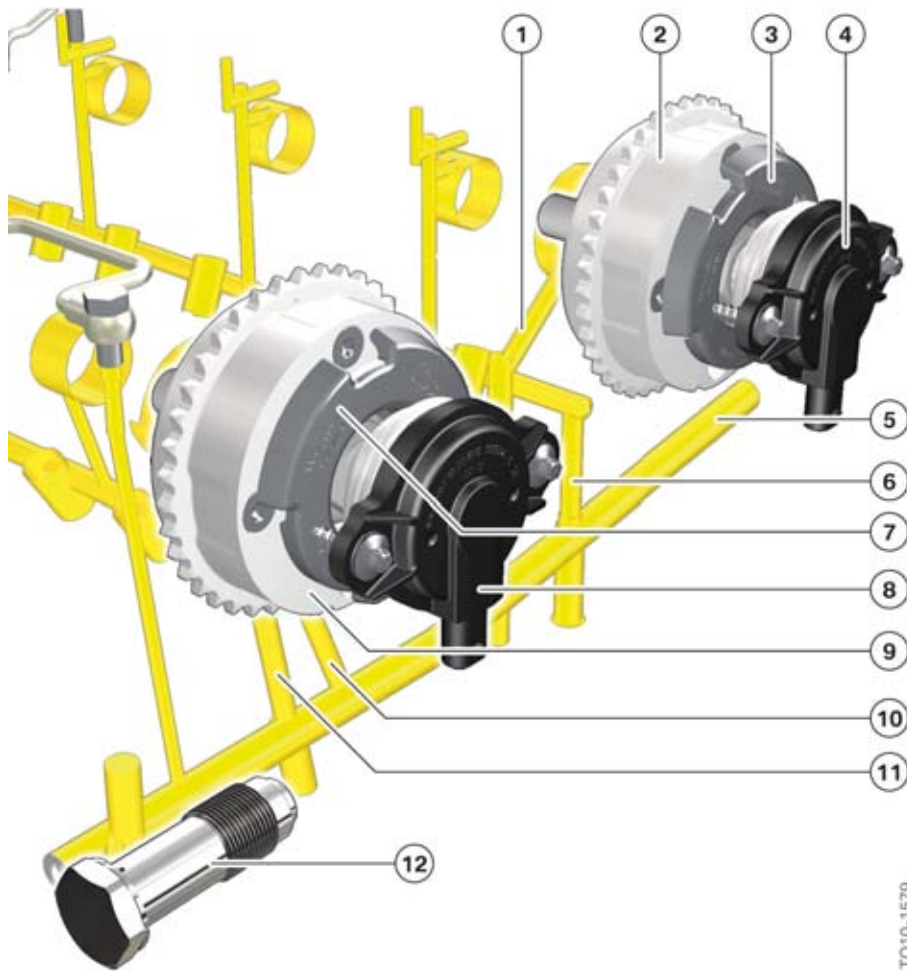

N20 engine, VANOS with oil supply

TO10-1579

Index	Explanation
1	Oil passage to VANOS unit, intake side
2	VANOS unit, intake side
3	Camshaft sensor wheel, intake camshaft
4	VANOS solenoid actuator, intake side
5	Main oil passage
6	Oil passage for intake camshaft and HVCC elements
7	Camshaft sensor wheel, exhaust camshaft
8	VANOS solenoid actuator, exhaust side
9	VANOS unit, exhaust side
10	Oil passage to VANOS unit, intake side
11	Oil passage for exhaust camshaft and HVCC elements
12	Chain tensioner

N20 Engine

2. Engine Components

The following graphic shows the oil passages in the VANOS unit. The intake camshaft can be “advanced” with the passages shaded light yellow; the VANOS unit can be “retarded” with the passages shaded dark yellow.

The cam shaft sensor wheels require a new special tool for proper positioning, tool # 2 212 830. Please refer to the repair instructions for more information.

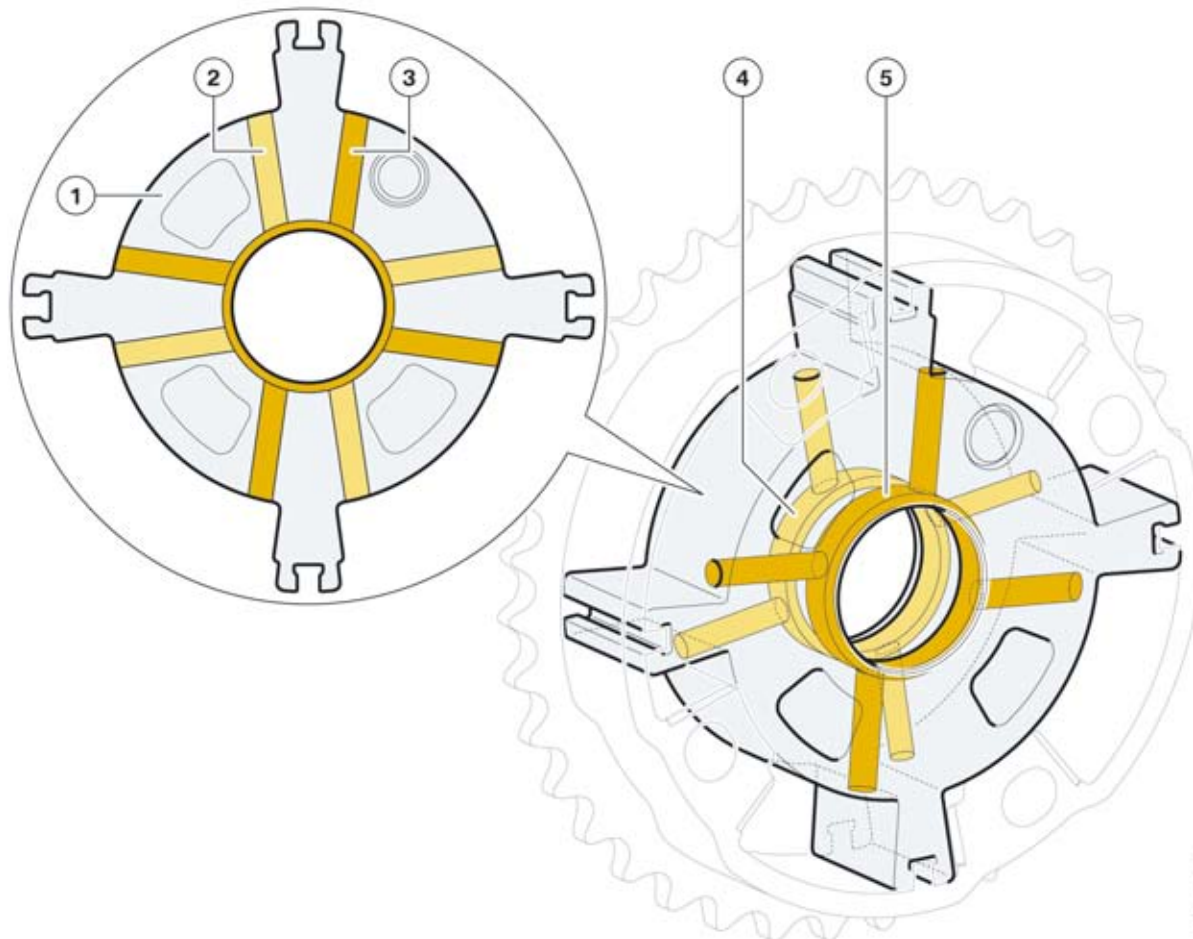

N20 engine, VANOS unit, intake camshaft

Index	Explanation
1	Rotor
2	Oil passage for advancing the timing
3	Oil passage for retarding the timing
4	Oil passage for advancing the timing
5	Oil passage for retarding the timing

The locking pin ensures that the VANOS unit is locked in a set position when in the depressurized state. The spiral or torsion spring (not shown here) is designed to compensate the middle camshaft friction, because without the spring the VANOS adjusts much faster to “retarded” (with friction) than to “advanced” (against friction). The locking effect is provided by the oil pressure, which when the

N20 Engine

2. Engine Components

actuator is nonregistered always forces the VANOS unit into the locking position (where the locking pin engages and blocks the VANOS unit). The timing can be adjusted in this way. This is important when the engine is started to ensure exact timing. The locking pin is simultaneously supplied with the oil pressure available for timing advance via oil passages in the VANOS unit. If the camshaft is to be “advanced”, the locking pin is then forced by the applied oil pressure against the locking spring towards the cartridge and the locking cover is released for VANOS adjustment.

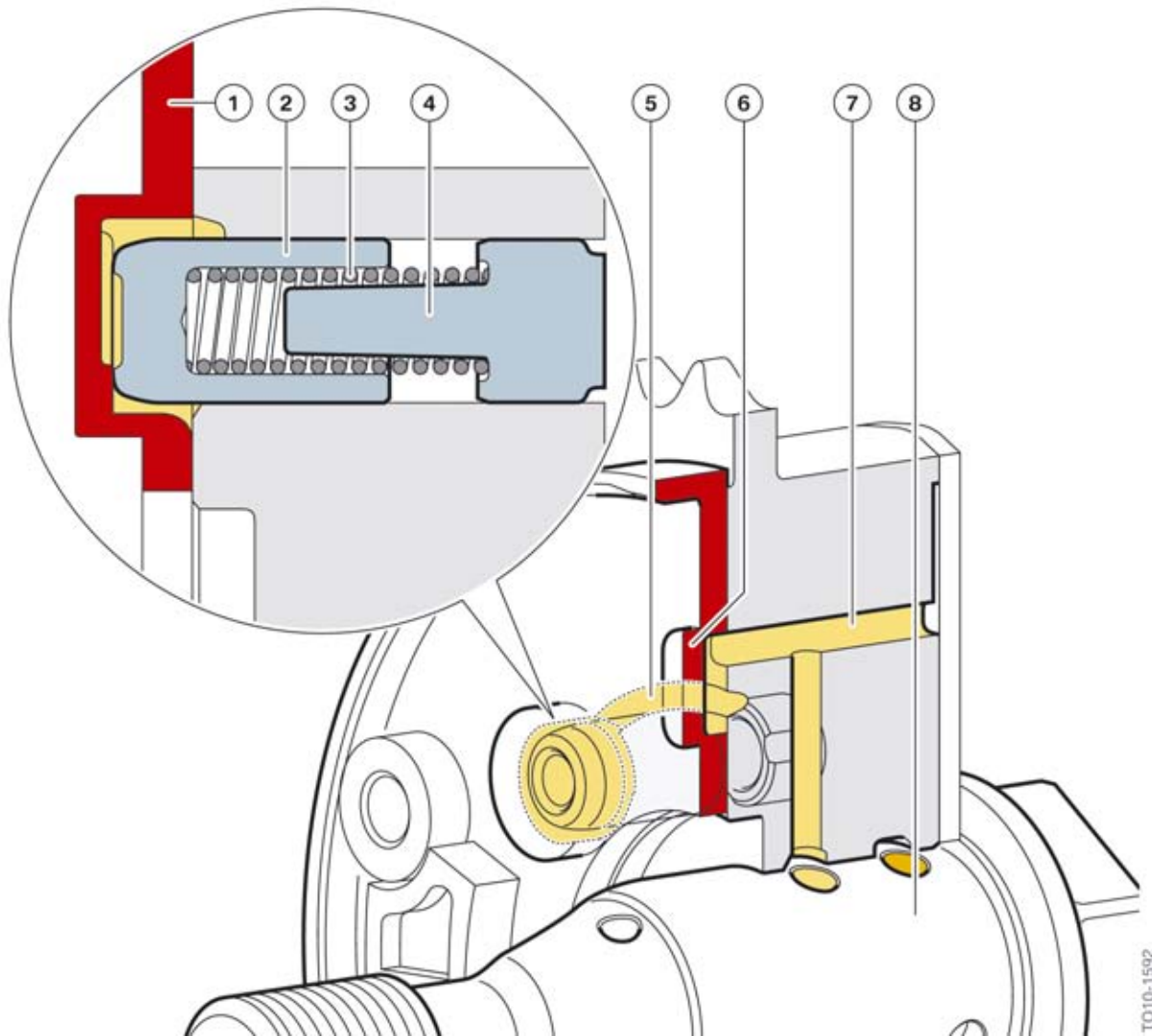

N20 engine, locking pin

Index	Explanation
1	Locking cover
2	Locking pin
3	Locking spring
4	Cartridge

N20 Engine

2. Engine Components

Index	Explanation
5	Oil passage
6	Locking cover
7	Oil passage
8	VANOS central valve

The VANOS unit is secured to the camshaft by the VANOS central valve. The oil flow into the VANOS unit is simultaneously controlled by this VANOS central valve. The system is actuated by a solenoid actuator (which presses against the plunger (4) of the VANOS central valve) thereby switching this valve from advance to the retard position.

The plunger in the central valve controls the oil flow. In the illustration below the plunger is shown extended. The large graphic shows the flow of oil from the main oil passage into the VANOS unit, while the small graphic shows the flow of oil from the VANOS unit into the cylinder head.

N20 Engine

2. Engine Components

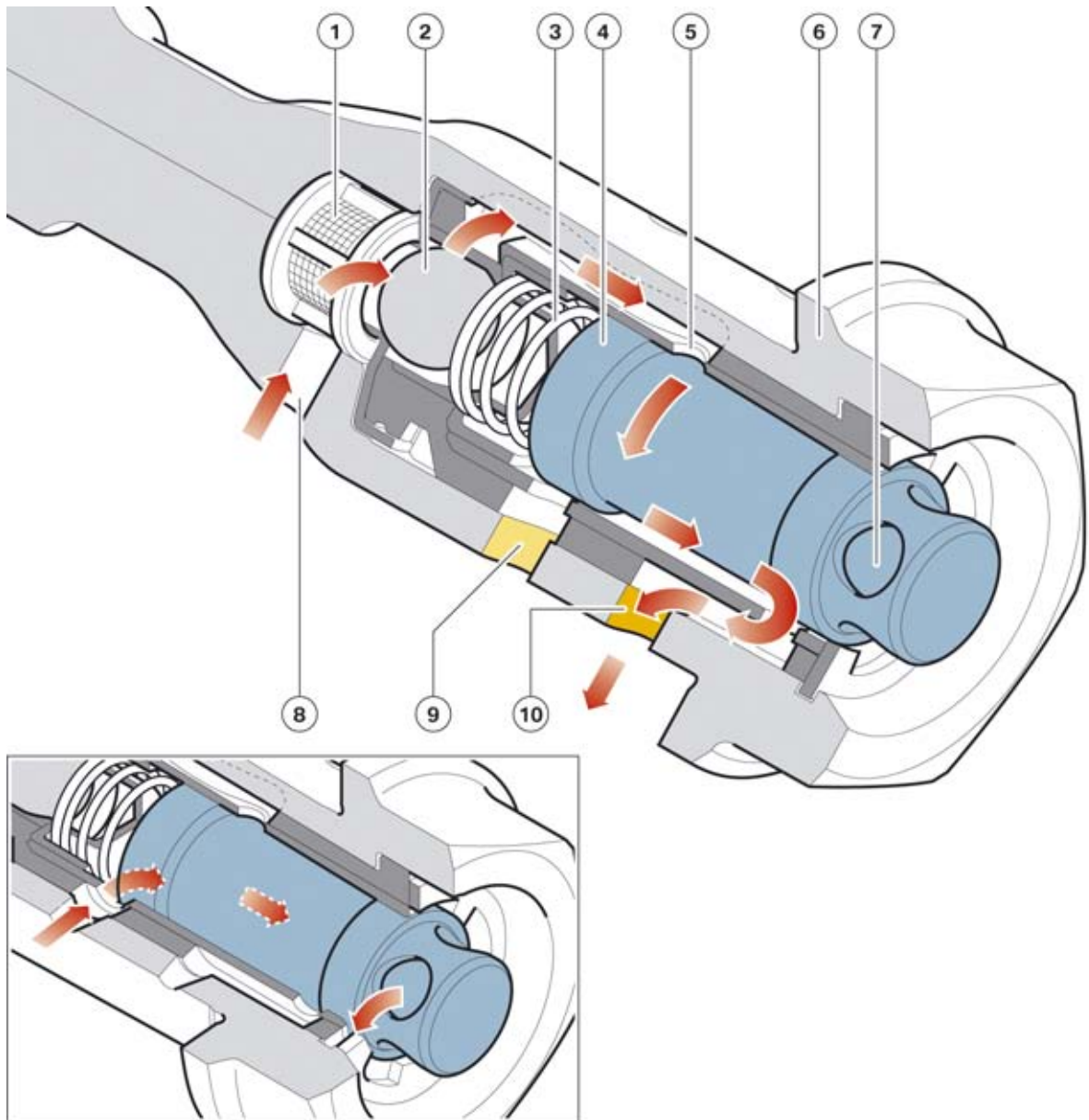

N20 engine, VANOS central valve, intake camshaft

TO10-1593

Index	Explanation
1	Filter
2	Ball
3	Spring
4	Plunger
5	Sleeve
6	Housing

N20 Engine

2. Engine Components

Index	Explanation
7	Opening in plunger
8	Oil supply from main oil passage
9	Bore to oil passage in VANOS (timing advance)
10	Bore to oil passage in VANOS (timing retard)

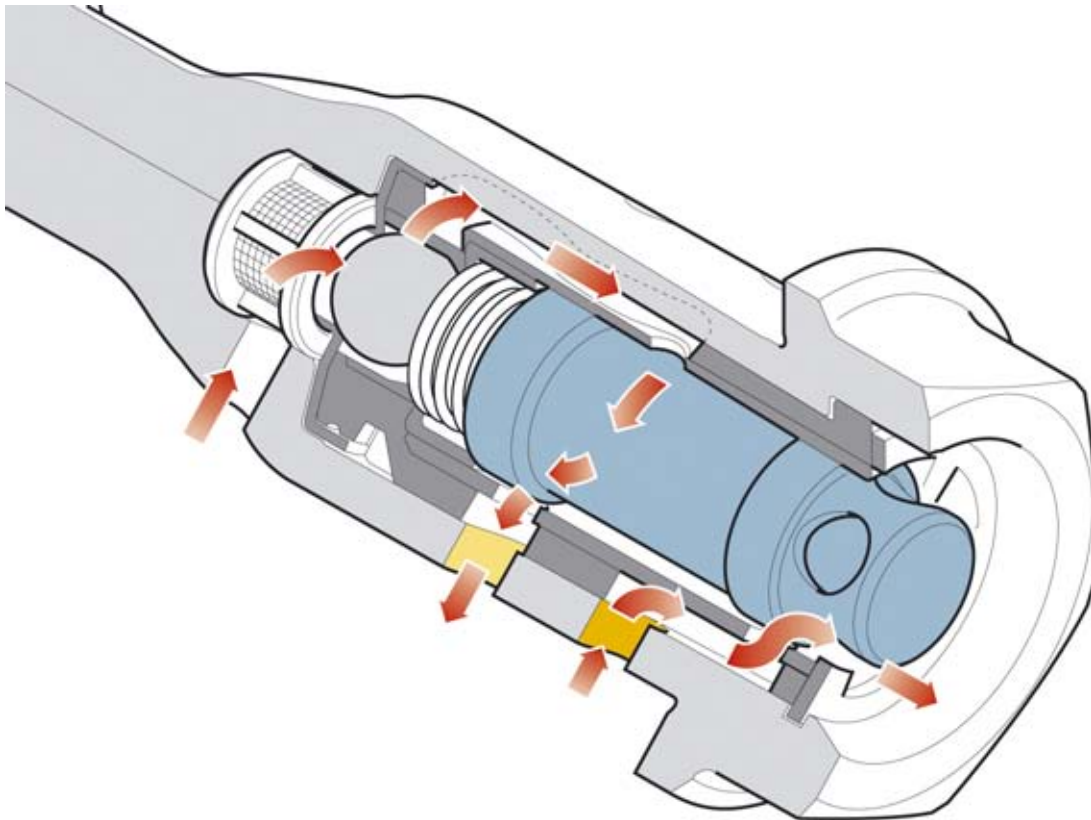

N20 engine, VANOS central valve, intake camshaft

Valve lift control

As can be seen from the following graphic, valve lift control with the Valvetronic servomotor is identical in terms of design to that of the N55 engine. The eccentric shaft sensor is integrated in the Valvetronic servomotor.

The system uses Valvetronic III, which is already used in the N55 engine.

N20 Engine

2. Engine Components

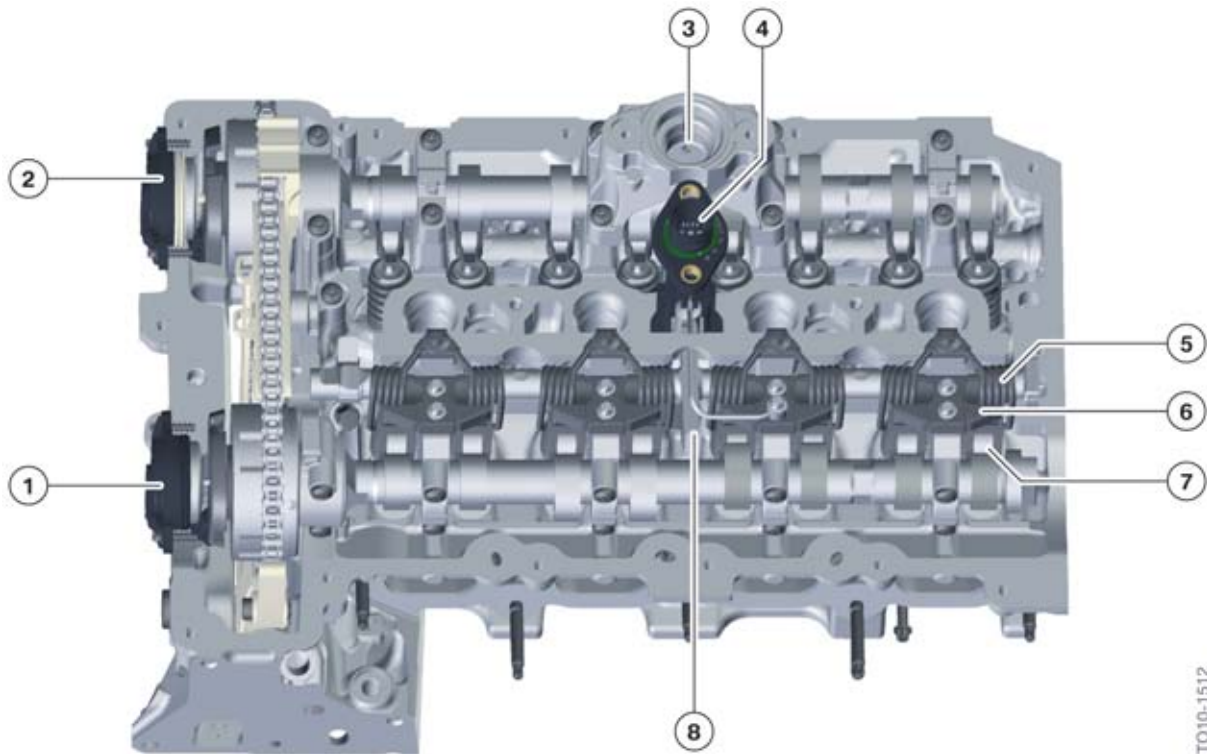

N20 engine, cylinder head

TO10-1512

Index	Explanation
1	VANOS solenoid actuator, intake
2	VANOS solenoid actuator, exhaust
3	Roller tappet, high-pressure pump
4	Valvetronic servomotor
5	Spring
6	Guide block
7	Intermediate lever
8	Eccentric shaft

2.6. Belt drive

The belt drive consists of a main belt drive with alternator and A/C compressor and an auxiliary belt drive with the power steering pump. The main belt drive is equipped with a belt tensioner, the auxiliary belt drive is an elasto-belt tensioning system.

N20 Engine

2. Engine Components

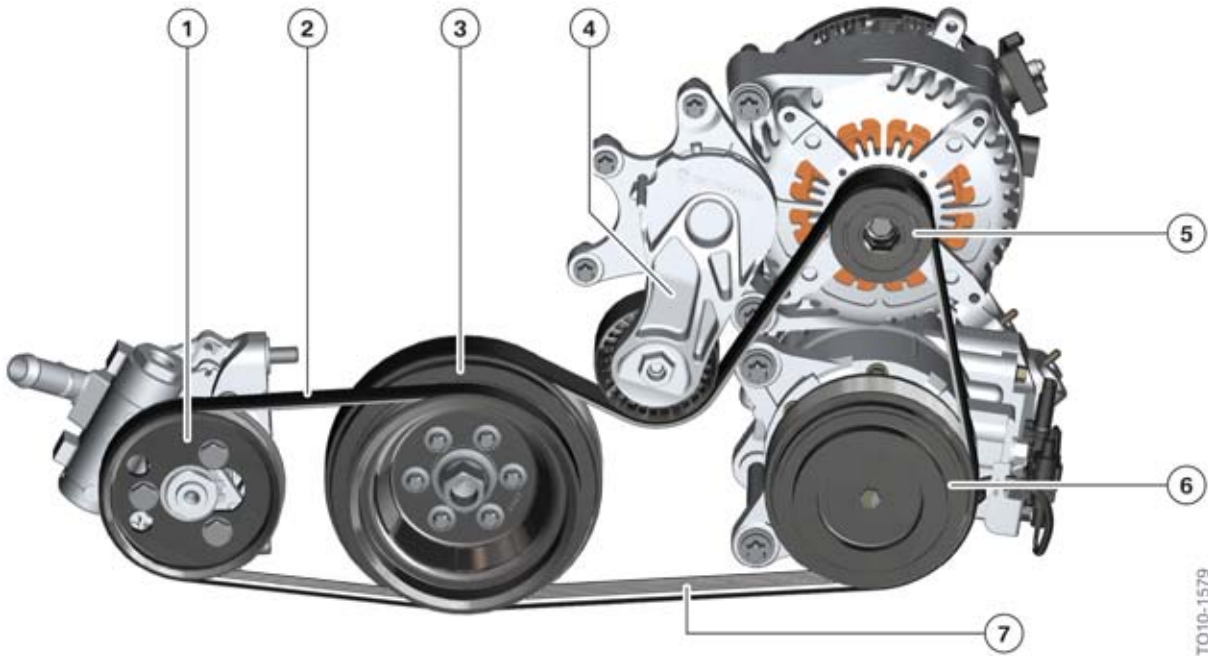

TO10-1579

N20 engine, belt drive

Index	Explanation
1	Belt pulley, power steering pump
2	Belt, power steering pump
3	Belt pulleys, crankshaft
4	Belt tensioner
5	Belt pulley, alternator
6	Belt pulley, A/C compressor
7	Belt

N20 Engine

3. Oil Supply

The oil supply in the N20 engine is very similar to that in the N55 engine. There are a few changes to the design with some slight differences in operation. Due to the complexity of this system, it is discussed again in greater detail in this training material.

The special features of the oil supply in the N20 engine are:

- Map-controlled oil pump
- New pendulum-slide oil pump design
- New VANOS valves
- Chain tensioner for counterbalance shaft/oil pump drive
- Unfiltered oil cooling
- New combined oil pressure and temperature sensor.

3.1. Overview

The following hydraulic circuit diagram and graphics provide an overview of the N20 oil supply and a better understanding of the actual layout of the oil passages in the engine.

N20 Engine

3. Oil Supply

3.1.1. Hydraulic circuit diagram

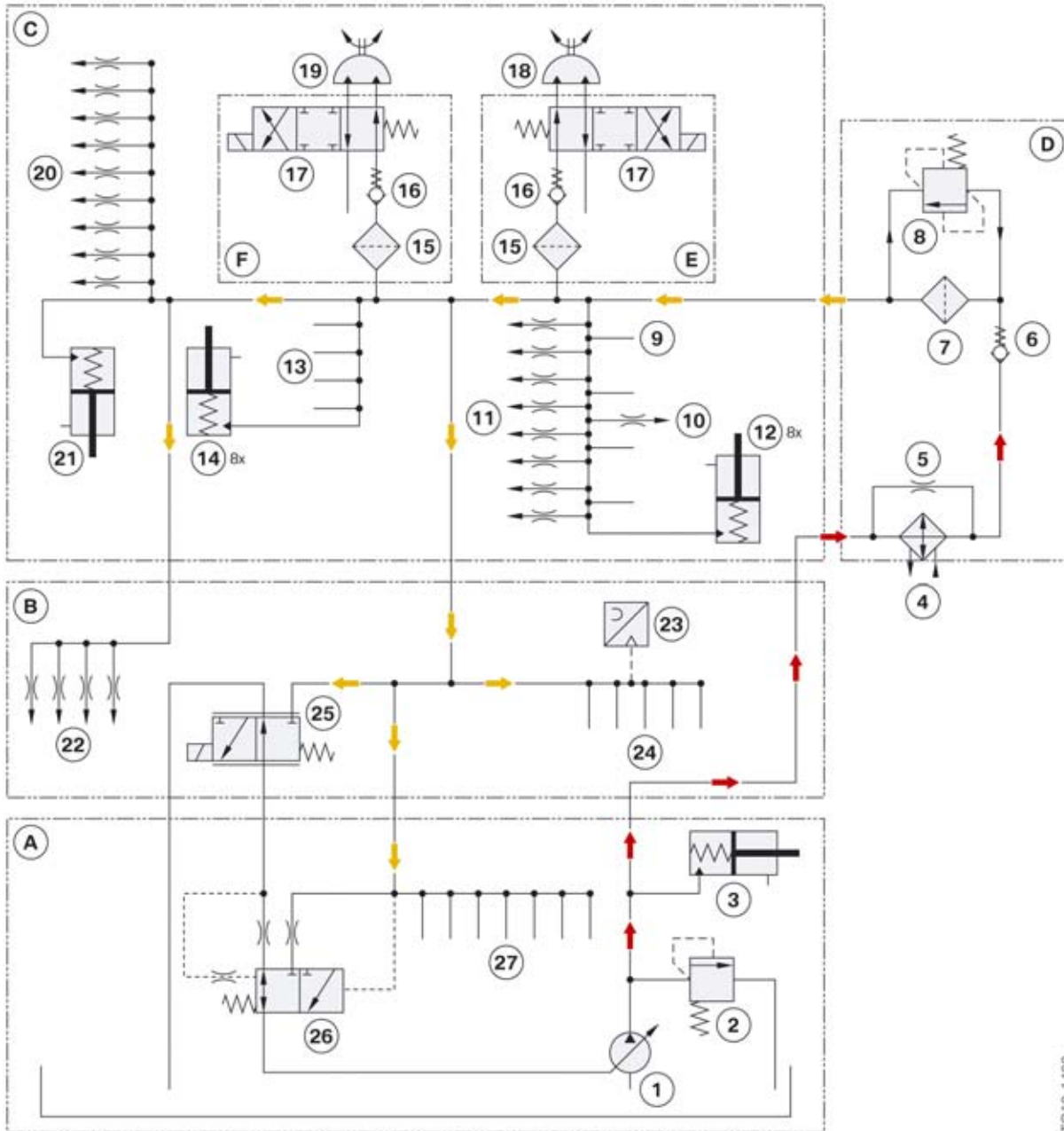

TO10-1400

N20 engine, hydraulic circuit diagram

Index	Explanation
A	Oil sump
B	Crankcase
C	Cylinder head
D	Oil filter module

N20 Engine

3. Oil Supply

Index	Explanation
E	VANOS central valve, intake camshaft (also oil supply, lubrication point, camshaft thrust bearing)
F	VANOS central valve, exhaust camshaft (also oil supply, lubrication point, camshaft thrust bearing)
1	Oil pump
2	Pressure-limiting valve
3	Chain tensioner, counterbalance shaft and oil pump drive
4	Engine oil-to-coolant heat exchanger
5	Permanent bypass
6	Non-return valve
7	Oil filter
8	Filter bypass valve
9	Lubrication points, intake camshaft bearings (via 4th bearing, supply of vacuum pump)
10	Oil spray nozzle, gearing, Valvetronic servomotor
11	Oil spray nozzles, cams, intake camshaft
12	Hydraulic valve clearance compensation (HVCC), intake side
13	Lubrication points, bearings, exhaust camshaft
14	Hydraulic valve clearance compensation (HVCC), exhaust side
15	Non-return valve
16	Filter
17	4/3-way valve
18	VANOS unit, intake camshaft
19	VANOS unit, exhaust camshaft
20	Oil spray nozzles, cams, exhaust camshaft
21	Chain tensioner, timing chain
22	Oil spray nozzles for piston crown cooling
23	Combined oil pressure and temperature sensor
24	Lubrication points, crankshaft main bearings
25	Map control valve
26	Emergency valve/pressure limiting blow off valve
27	Lubrication points, bearings, counterbalance shafts

N20 Engine

3. Oil Supply

3.1.2. Oil passages

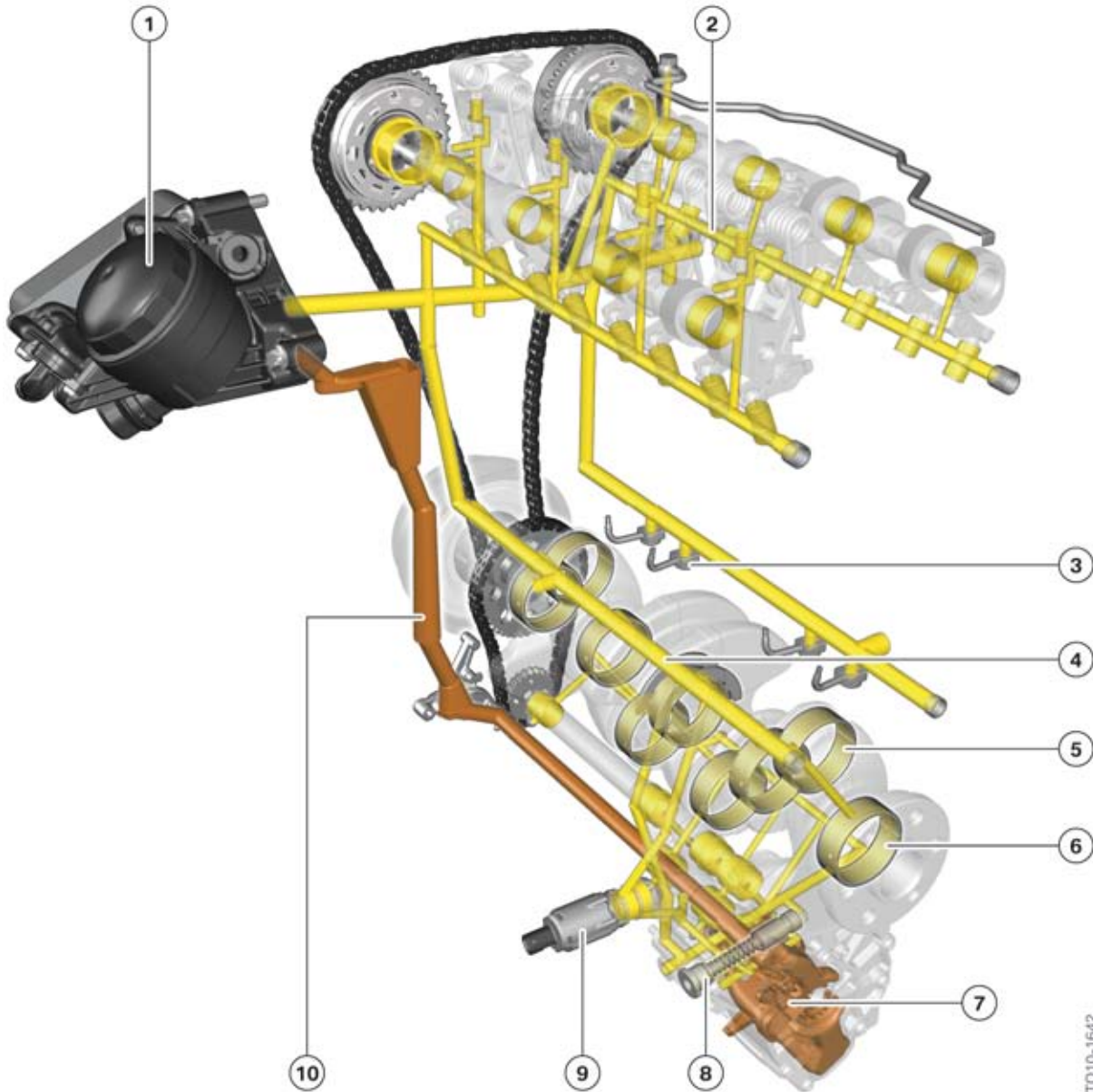

N20 engine, oil passages (phantom rear left view)

Index	Explanation
1	Oil filter
2	Lubrication points in cylinder head (details, see below)
3	Oil spray nozzles for piston crown cooling
4	Main oil passage
5	Lubrication points, connecting rod bearings
6	Lubrication points, crankshaft main bearings

N20 Engine

3. Oil Supply

Index	Explanation
7	Oil pump
8	Emergency valve/pressure limiting blow off valve
9	Map control valve
10	Unfiltered oil passage

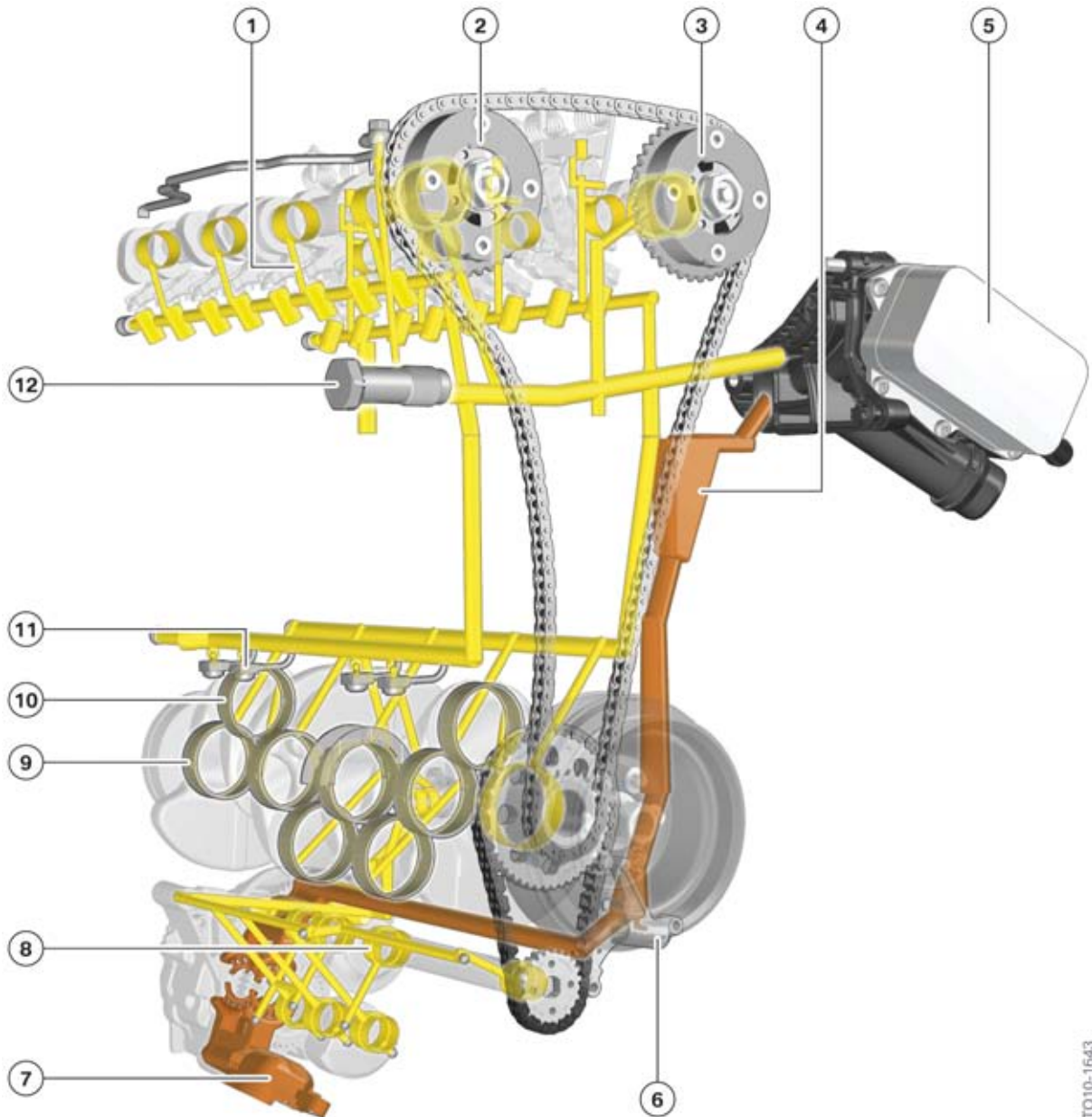

N20 engine, oil passages (phantom right front view)

TO10-1643

N20 Engine

3. Oil Supply

Index	Explanation
1	Lubrication points in cylinder head (details, see below)
2	VANOS actuator unit, exhaust camshaft
3	VANOS actuator unit, intake camshaft
4	Unfiltered oil passage
5	Engine oil-to-coolant heat exchanger
6	Chain tensioner, counterbalance shaft and oil pump drive
7	Oil suction pipe
8	Lubrication points, counterbalance shaft bearings
9	Lubrication points, crankshaft main bearings
10	Lubrication points, connecting rod bearings
11	Oil spray nozzles for piston crown cooling
12	Chain tensioner, timing chain

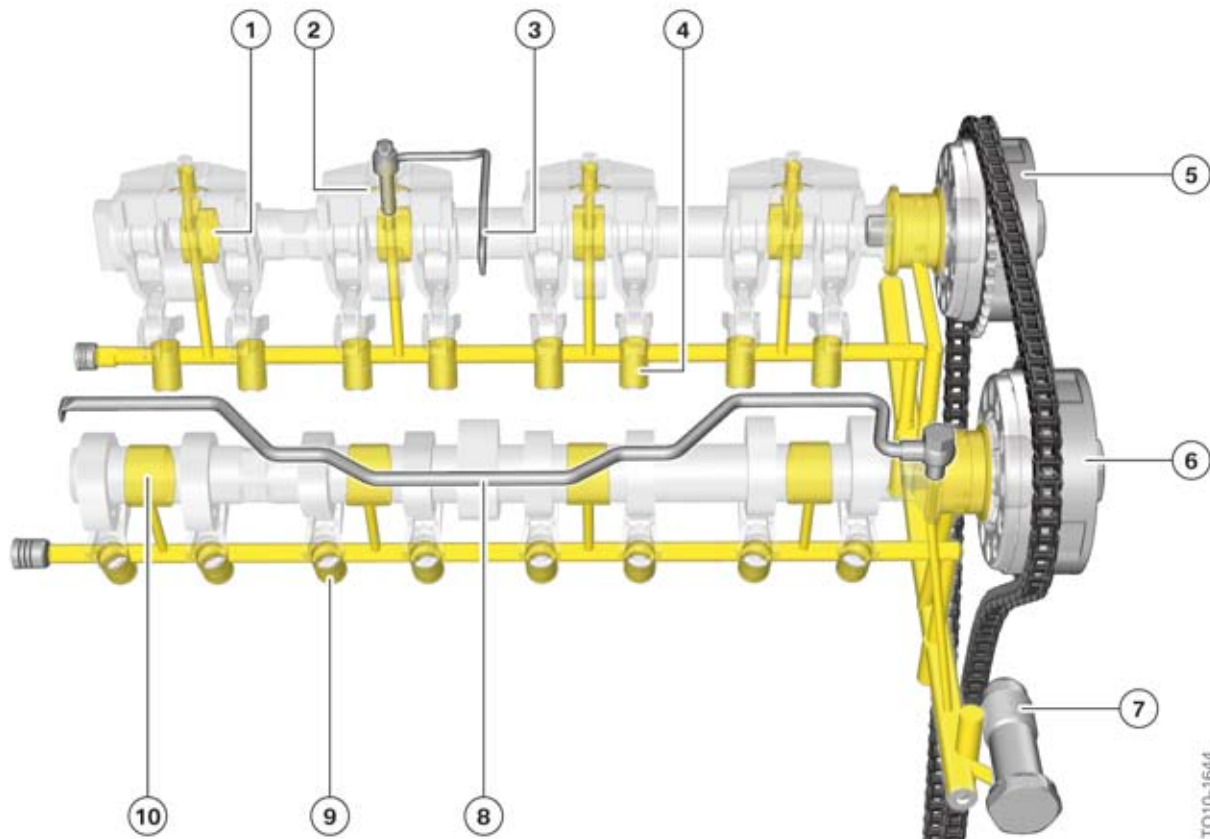

N20 engine, oil passages in cylinder head (phantom left view)

TO10-1644

N20 Engine

3. Oil Supply

Index	Explanation
1	Lubrication points, intake camshaft bearings
2	Oil spray nozzles in Guide block for intermediate levers and intake cams
3	Oil spray nozzle, gearing, Valvetronic servomotor
4	HVCC elements, intake valves
5	VANOS actuator unit, intake camshaft
6	VANOS actuator unit, exhaust camshaft
7	Chain tensioner, timing chain
8	Oil pipe for oil spray nozzles, exhaust cams
9	HVCC elements, exhaust valves
10	Lubrication points, exhaust camshaft bearings

N20 Engine

3. Oil Supply

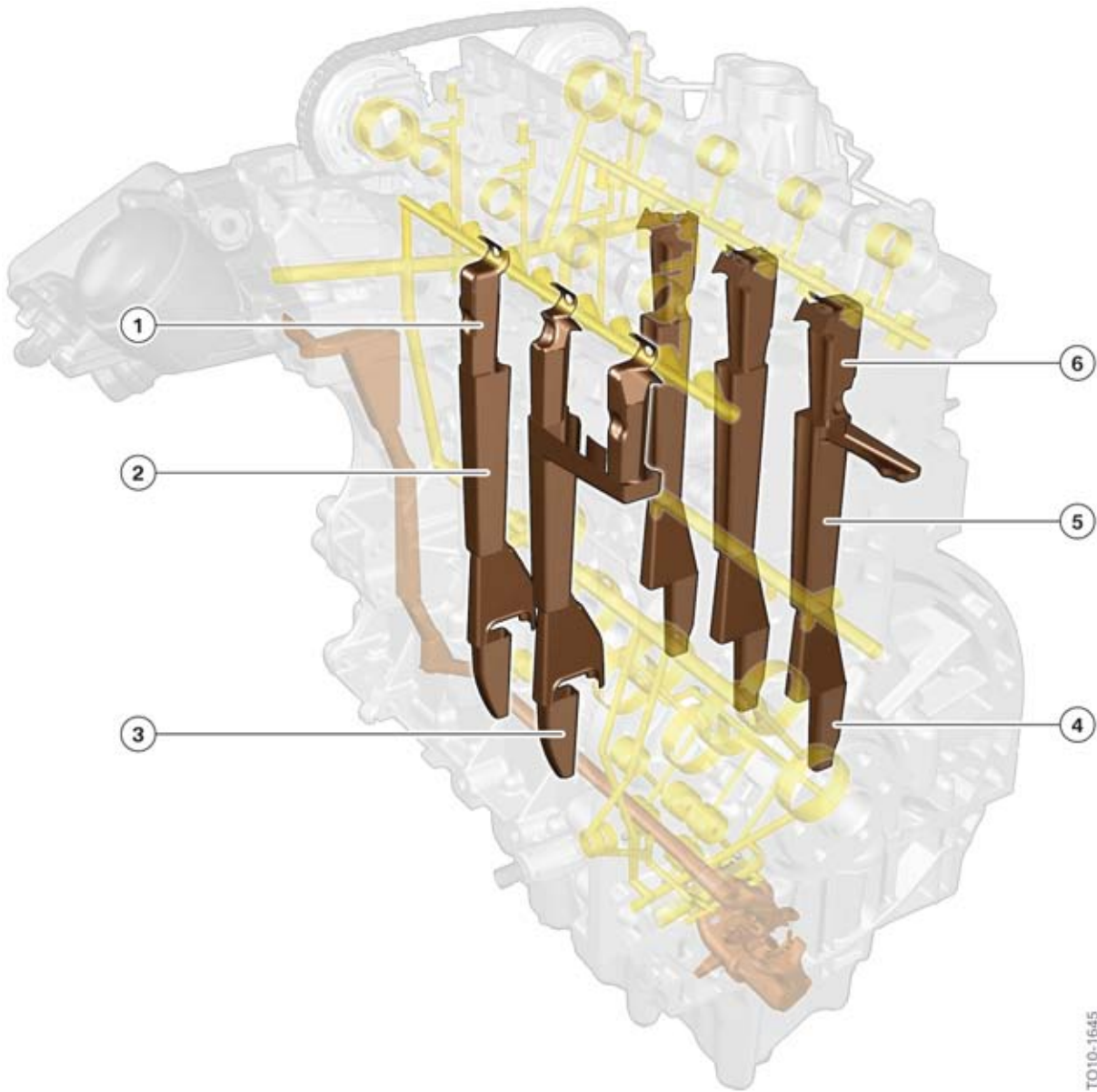

TO10-1645

N20 engine, oil return passages (phantom left rear view)

Index	Explanation
1	Ventilation passages in cylinder head
2	Ventilation passages in crankcase
3	Ventilation passages in bedplate
4	Oil return passages in bedplate
5	Oil return passages in crankcase
6	Oil return passages in cylinder head

N20 Engine

3. Oil Supply

3.2. Oil pump and pressure control

A variable-volumetric-flow slide oil pump is used in the N20 engine. Despite its shape being modified, its function is familiar to that of the N63 and N55 engines. Although these two engines share a similar oil pump, they differ in how they are controlled. While the oil pump in the N63 engine is volumetric-flow-controlled, in the N55 and N20 engines its map-controlled.

3.2.1. Oil pump

The oil pump is connected to the counterbalance shaft housing. The oil pump is located at the flywheel side of the engine, but is driven at the front of the engine by the crankshaft via a chain. The chain sprocket connects to the oil pump via a long shaft. This shaft forms part of the first counterbalance shaft which rotates in the same direction as the crankshaft. The rotational speed is stepped down from the counterbalance shaft for the oil pump via a pair of gears.

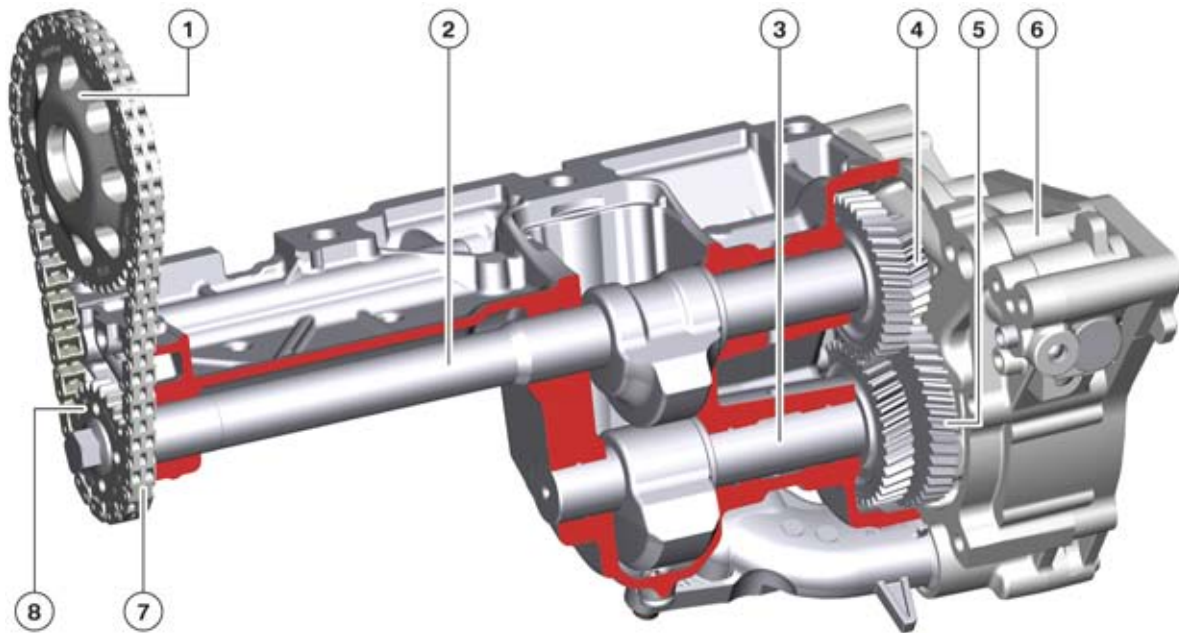

N20 engine, oil pump with counterbalance shafts

TO10-1399

Index	Explanation
1	Sprocket on crankshaft
2	Upper counterbalance shaft
3	Lower counterbalance shaft
4	Gear, upper counterbalance shaft
5	Gear, oil pump
6	Oil pump
7	Tooth-type chain, counterbalance shaft and oil pump drive
8	Counterbalance shaft sprocket

N20 Engine

3. Oil Supply

As already mentioned, the function of the slide oil pump has not changed. The main difference is that the slide mechanism no longer pivots on an axis during adjustment, but instead is moved in parallel.

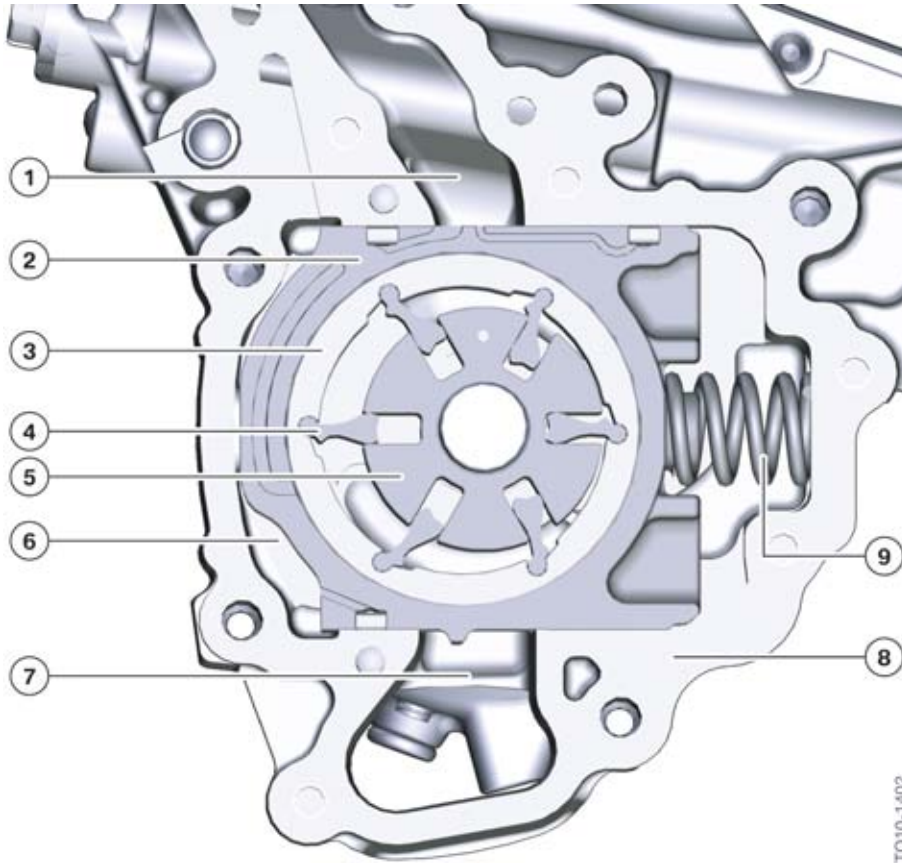

N20 engine, inner workings of oil pump

Index	Explanation
1	Pressure side
2	sliding block
3	Outer rotor
4	Pendulum
5	Inner rotor
6	Control oil chamber
7	Suction side
8	Housing
9	Main spring

As in all newer generation slide oil pumps the oil acts directly on the slide mechanism. The higher the pressure here, the more the sliding block is forced against the spring in the direction of the center of the pump, which reduces the volumetric displacement. This reduces the pump delivery rate and limits

N20 Engine

3. Oil Supply

the pressure in the system. In this way, it is possible to achieve purely hydraulic/mechanical control of the volumetric flow, allowing sufficient operating pressure to be set. This pressure is determined by the strength of the main spring in the oil pump which acts on the sliding block.

As with the N55 the N20 engine features a map control valve which the DME activates to influence the pump delivery rate.

The oil pump cannot be replaced separately. The entire unit including the counterbalance shafts must be replaced if the oil pump fails.

3.2.2. Control

Controlling the delivery rate of the oil supply pump is crucial component of the BMW EfficientDynamics strategy. Essentially, engineers attempt to design a pump with regard to its power input as small as possible in order to keep engine losses as low as possible. On the other hand, the pump must also be designed in such a way as to deliver sufficient volume and pressure under all operating conditions. A conventional, non-variable pump would therefore have to be designed in accordance with the second standpoint, i.e. large enough to be able to deliver sufficient amounts of oil at all times. However, this means that the pump may deliver far too much oil volume and pressure over a large portion of its service life and thereby draw more energy than necessary from the powertrain. For this reason, more and more pumps are now variable in design and their control is becoming increasingly more fine-tuned. Thus the conventional pump was followed by volumetric flow control, which was subsequently extended to included map control.

Volumetric flow control

The N20 uses a vane type oil pump. The core of this variable-volumetric-flow oil pump is the sliding mechanism. It can be displaced with respect to the pump shaft to vary the pump's delivery rate.

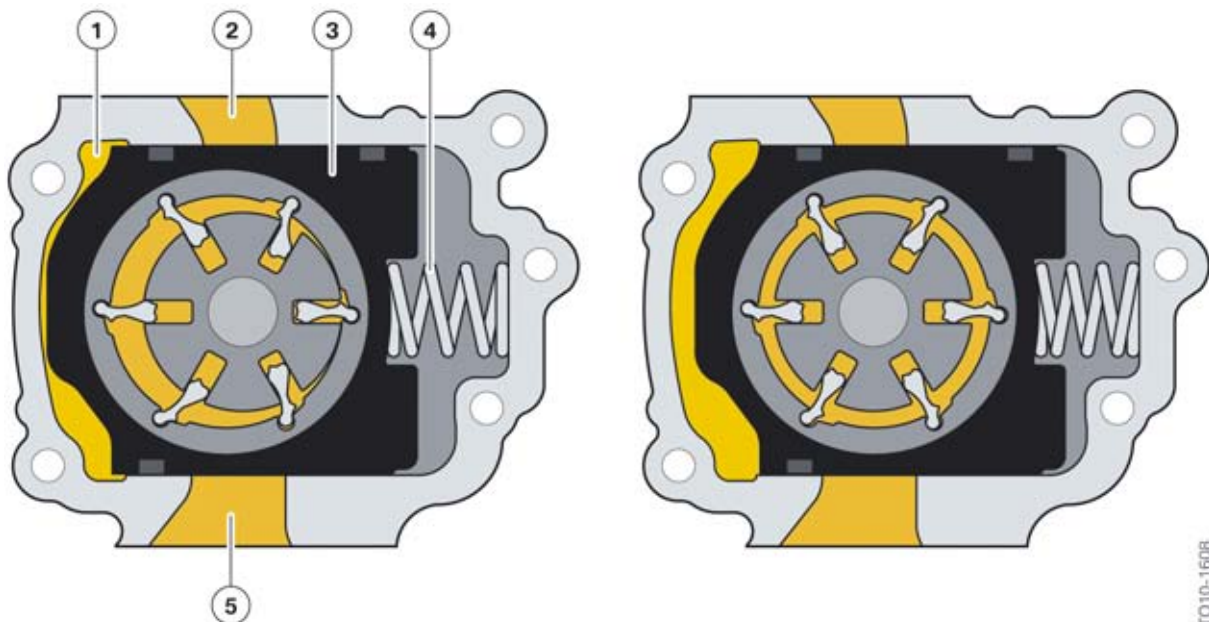

N20 engine, oil pump (left at maximum delivery, right at minimum delivery)

TO10-1608

N20 Engine

3. Oil Supply

Index	Explanation
1	Control oil chamber
2	Pressure side
3	Sliding block
4	Main spring
5	Suction side

In the maximum delivery setting the sliding block is positioned off-center with respect to the pump shaft. In this way, an increase in volume occurs on the suction side and correspondingly a decrease in volume occurs on the pressure side. This generates high pump capacity.

When the sliding block is displaced towards the pump shaft, the pump volume is reduced. Therefore, the pump capacity is reduced until finally the minimum delivery is reached.

The position of the sliding block is dependent on the oil pressure in the pump's control oil chamber. This pressure pushes on the sliding block against the force of a spring. When the pressure is low in the control chamber, the sliding block is moved off-center by the force of the spring and the delivery rate is high. When the pressure is high in the control chamber, the sliding block is displaced towards the center of the pump as the spring is compressed and the delivery rate decreases.

With pure volumetric flow control, the pressure in the control oil chamber corresponds to that in the main oil passage. In this way, it is possible to maintain a relatively uniform pressure irrespective of the necessary volumetric flow. One reason for large differences in the necessary volumetric flow in the oil circuit is the VANOS variable camshaft timing control system. In the VANOS units the oil is used not only for lubrication purposes but also for hydraulic actuation of the cam timing. A large oil volume is thus necessary during the adjustment phase, which causes the pressure in the system to drop. The falling pressure causes the sliding block in the oil pump to be displaced in the direction of higher delivery. In this way, a higher volumetric flow is made available and the pressure drop is compensated for.

As already mentioned, the pressure that is set in the oil system is dependent on the force of the spring which counteracts the pressure in the control oil chamber. With a softer spring, the sliding block can be displaced more easily, i.e. with a lower pressure, towards the center. With a harder spring, more pressure is required to reduce the volumetric displacement of the pump. Thus the appropriate spring was calculated and selected to properly operate the N20 oil system.

Map control represents a further fine-tuning of volumetric flow control.

Map control

Map control is used to influence the pressure in the control oil chamber of the pump. Two valves are involved in this process, a solenoid valve called the map control valve and a hydraulic valve which also acts as a fail-safe. This "fail safe" valve is also referred to as an emergency valve or a second-level mode control valve.

The map control valve is located on the left side of the engine (bolted to bedplate) and channels the oil pressure from the main oil passage to the control oil chamber within the pump. Its purpose is to influence pump volume output by gradually and smoothly reducing the oil pressure in the control oil chamber.

N20 Engine

3. Oil Supply



Map control valve

The further it reduces the pressure, the more volume is delivered by the oil pump as the sliding block moves further off center. However, this mode does not produce a positive effect on energy saving. Therefore the main spring in the oil pump which acts on the sliding block is softer than the one used in a purely volumetric-flow-controlled system. In other words, the sliding block can be moved to a centred position very easily, as the pump switches to minimum delivery. In this way, there are lower pressure conditions in the oil system, which in turn translates into less energy spent to drive the oil pump. Where necessary, the pressure in the control oil chamber can now be reduced by the map control valve which also reduces the delivery rate.

The second stage of map control is a hydraulic/emergency valve which is located in the oil pump housing.

N20 Engine

3. Oil Supply

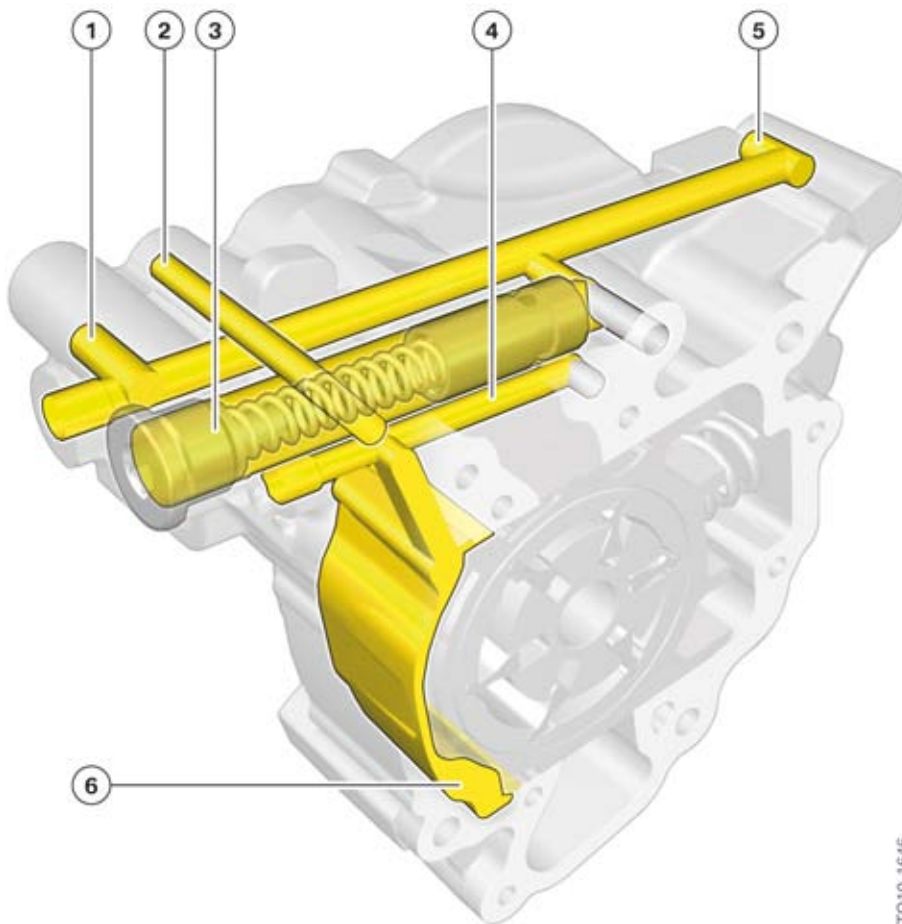

TO10-1646

N20 engine, oil pump with hydraulic emergency valve

Index	Explanation
1	Connection from main oil passage
2	Connection from map control valve
3	Hydraulic/Emergency valve
4	Channel to control oil chamber
5	Connection to counterbalance shafts
6	Control oil chamber

This is 3/2-way valve is used to channel the main oil pressure into the oil pump's control oil chamber. The oil from the main oil passage forces a plunger against a spring until the passage to the oil pump control chamber is opened. The oil pressure from the map control valve acts on the other end of the plunger. The pressure in the map control valve port counter acts the main oil passage pressure to fine tune the oil pressure within the oil pump's volume control chamber which in turn varies the oil delivery rate of the pump.

N20 Engine

3. Oil Supply

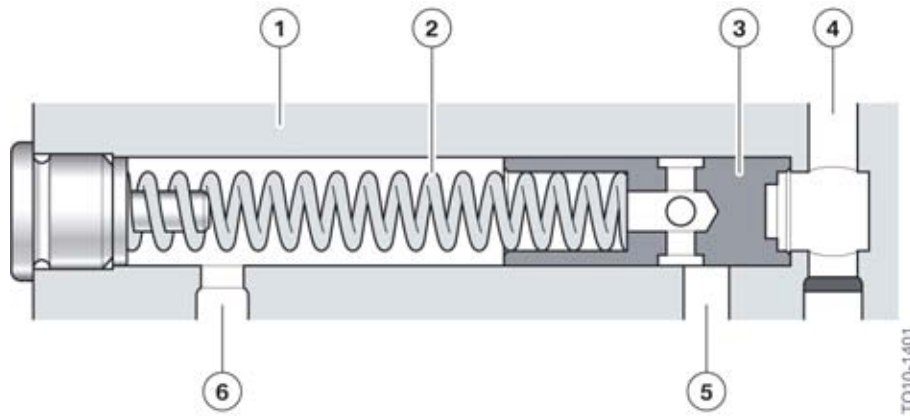

N20 engine, emergency valve

Index	Explanation
1	Oil pump housing
2	Emergency spring
3	Plunger
4	From main oil passage
5	To control oil chamber in oil pump
6	From map control valve

The hydraulic valve is located between the map control valve and the control oil chamber in the oil pump. The following graphic shows this in a simplified oil circuit.

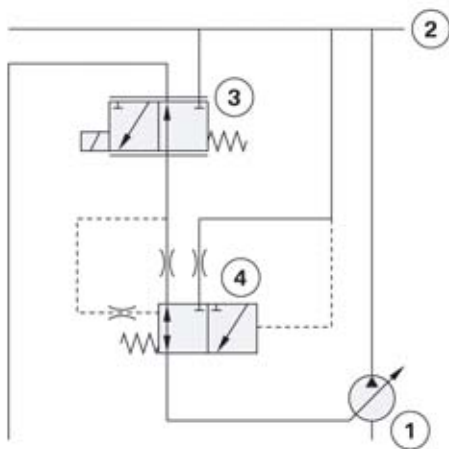

N20 engine, simplified map control oil circuit

N20 Engine

3. Oil Supply

Index	Explanation
1	Oil pump
2	Main oil passage
3	Map control valve
4	Emergency valve

In map control mode oil pressure acts on both ends of the plunger. The oil pressure directly from the main oil passage acts against the emergency valve spring. At the same time the oil pressure released by the map control valve acts on the other end, i.e. along with the emergency valve spring.

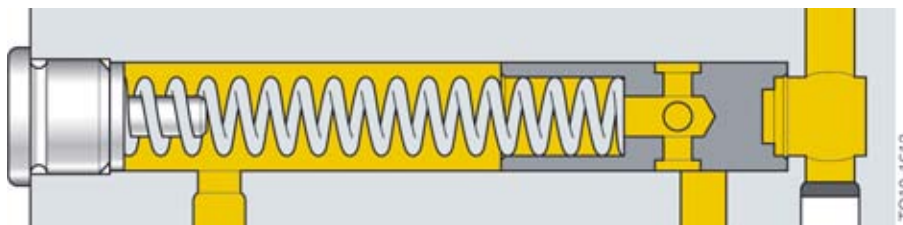

N20 engine, hydraulic 3/2-way valve with map control

The plunger remains constantly in its end position during map control. To displace the plunger, there would have to be a pressure of 5.5 bar in the main oil port to counter act the spring. This **never** arises in map control mode, since the maximum set pressure in the system is 4.5 bar in the circuit. In this setting the emergency valve forms a connection between the map control valve and the oil pump's control oil chamber (the valve is **closed** to the main oil duct).

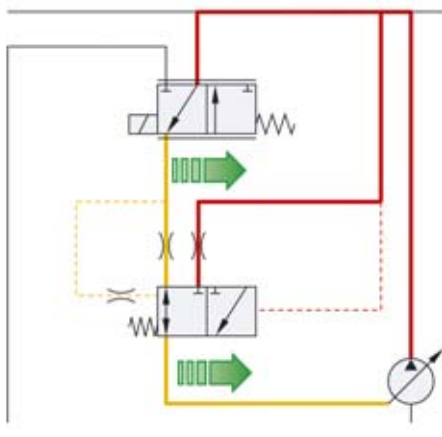

N20 engine, simplified oil circuit with map control

The pump delivery rate is controlled by the pressure in the pump's control oil chamber which in turn is determined directly by the DME via the map control valve.

Map control is the oil system's standard operating mode. It is always engaged when there are no faults in the system and the operating conditions do not exceed or drop below certain values (see below).

Up to now map control system would manage without the emergency valve. This is however a second stage of map control – a kind of fail safe mode.

N20 Engine

3. Oil Supply

If the map control valve is deactivated, the chamber at the end of the spring in the emergency valve is depressurized. Because the plunger is now only being held by the spring the main oil pressure displaces it and makes its way into the pump's control chamber. A pressure difference of 5.5 bar is required to switch the emergency valve into this position.

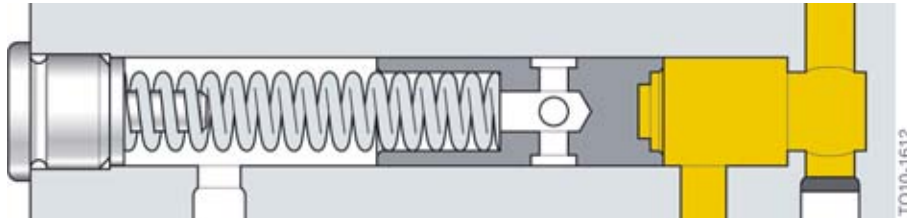

N20 engine, emergency valve with "second-level control"

In this mode the pressure is channelled from the main oil passage directly into the oil pump's control oil chamber.

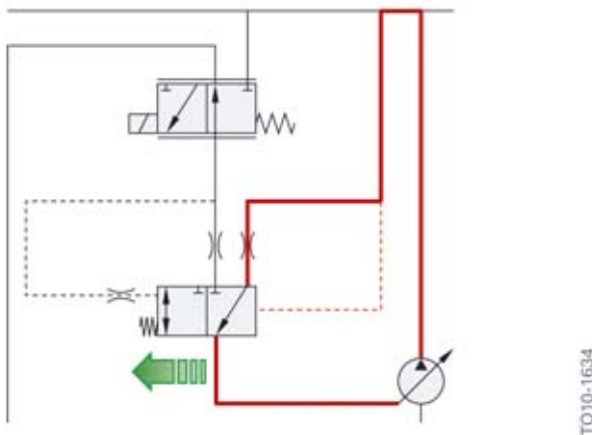

N20 engine, simplified oil circuit in emergency mode

There is no map control in emergency mode because the oil pressure is set to 5.5 bar max. and there is no oil admitted into the oil pump's control oil chamber below this level.

The map control valve is closed at zero current. Therefore, should the map control valve fail, the system is automatically in emergency mode, guaranteeing pressure limitation to 5.5 bar. As already mentioned, map control mode is the normal mode of operation. There are, however, several reasons why the DME will switch to emergency mode.

Emergency mode is applied in the following conditions:

- Map control valve faulty
- Oil pressure sensor faulty
- Outside temperature less than - 20 °C/- 4 °F
- High engine oil or coolant temperature
- Driving profile (e.g. high engine revs for a long time)

N20 Engine

3. Oil Supply

The oil pressure sensor signal allows the DME to identify whether the emergency valve is stuck. If this is the case, the DME attempts to free the emergency valve by applying a varying pressure buildup. If the emergency valve is stuck in the “closed” position, it is possible to continue map control. If, however, the emergency valve is stuck in the “open” position sufficient pressure buildup is no longer possible. The oil pressure indicator light is activated and the engine must be shut down immediately.

Summary

By applying oil pump map control, it is possible to deliver an oil supply to match demand and to reduce the average pressure level in the oil circuit. This ensures that the oil pump has a lower energy requirement.

The map control valve controls the pressure in the system and in turn allows the delivery rate to be controlled by the DME.

The following diagram shows (in simplified form) the pressure curves plotted against engine speed for different oil pumps.

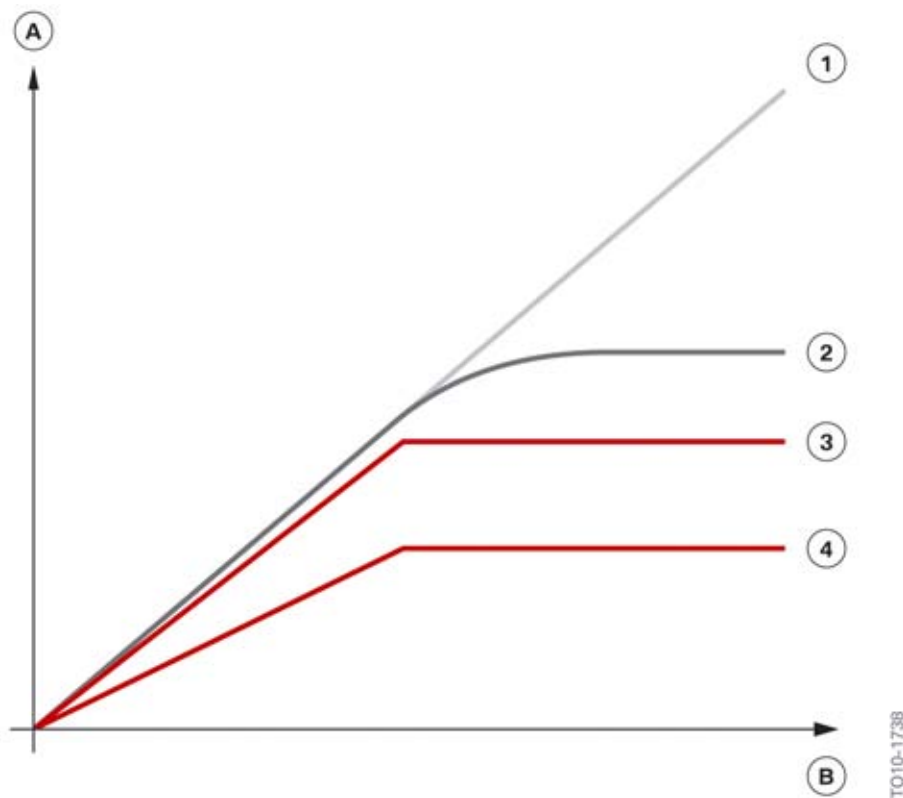

Simplified pressure curves for different oil pumps

N20 Engine

3. Oil Supply

Index	Explanation
A	Oil pressure
B	Engine speed
1	Non-controlled oil pump
2	Volumetric-flow-controlled oil pump
3	Map-controlled oil pump at full load
4	Map-controlled oil pump at partial load

The diagram illustrates the advantage of controlled oil pumps. When a sufficient oil pressure is reached, the delivery rate of the oil pump can be reduced. Lower pressure is synonymous with fuel saving. Thus the map-controlled oil pump offers the greatest advantage here, since it can be controlled regardless of engine speed. At partial load, for example, only lower pressures are required, because the crankshaft main bearings have to bear less load. Accordingly, a lower oil pressure can be set in the partial load range, which illustrates even more clearly the advantage over the volumetric-flow-controlled oil pump.

The oil pressure in map mode ranges between 1.5 and 4.5 bar.

The emergency valve has been integrated in the system as a fail safe and to facilitate a higher pressure in certain conditions. For example if the map control valve fails, it ensures the necessary pressure is built up and the oil pump pressure control of 5.5 bar.

3.2.3. Pressure-limiting valve

Additionally available to control the oil pump is a pressure-limiting valve, which is often also known as a cold-start valve.

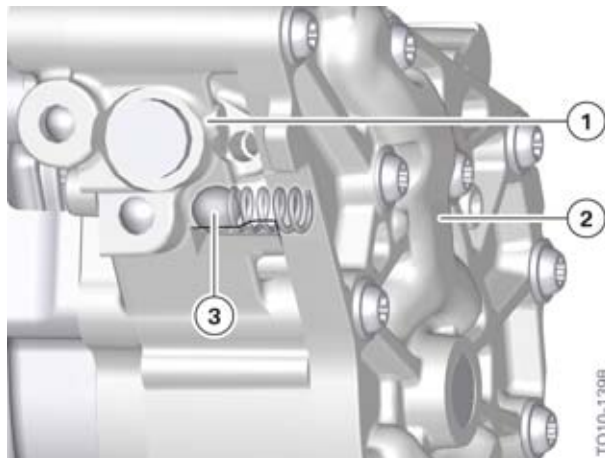

N20 engine, pressure-limiting valve in oil pump

Index	Explanation
1	Oil pump housing
2	Oil pump cover
3	Pressure-limiting valve

N20 Engine

3. Oil Supply

The pressure-limiting valve is located in the oil pump housing and in the oil circuit as the first component after the pump. It opens at a pressure of roughly 12 to 13 bar and discharges the oil directly into the oil sump. It is necessary at low temperatures and when the oil has a higher viscosity. In these situations the pressure-limiting valve prevents damage to components, in particular to the oil filter module and its seals. This is relevant at temperatures of below -20 °C / -4 °F, since map control is already active above this temperature.

3.3. Oil filtering and cooling

The N20 engine has a similar plastic oil filter housing as the N55 engine, to which the engine oil-to-coolant heat exchanger is also directly mounted. This entire unit is known as the oil filter module.

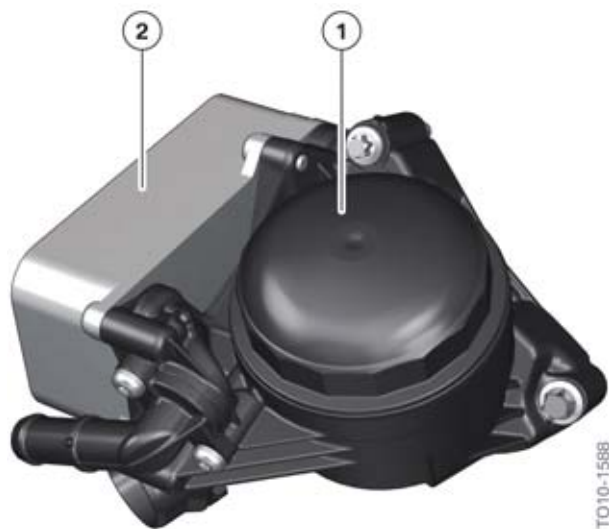

N20 engine, oil filter module

Index	Explanation
1	Oil filter
2	Engine oil-to-coolant heat exchanger

3.3.1. Oil cooling

In the N20 engine the engine oil-to-coolant heat exchanger is located in the oil circuit ahead of the oil filter. This is known as raw/unfiltered oil cooling, in contrast to clean oil cooling. This is due to the lead-free crankshaft and connecting rod bearings. Because these components are extremely sensitive to dirt particles, this arrangement brings the oil filter even closer to just before the bearing positions. The importance is even greater should auxiliary engine oil coolers be used in later models, as here there is always the risk of dirt getting into the oil circuit after an accident.

Permanent bypass

The N20 engine does not have a heat exchanger bypass valve. Instead, as the N55, it has a permanent bypass. This is a permanently open bypass around the engine oil-to-coolant heat exchanger. The bypass incorporates a flow restrictor to ensure that the majority of the oil flows through the engine oil-to-coolant heat exchanger.

N20 Engine

3. Oil Supply

3.3.2. Oil filtering

The full-flow oil filter used in the N20 engine. Instead of a non-return valve, a non-return diaphragm is mounted directly on the filter element. The function of this diaphragm is to prevent the oil filter from draining after the engine is shut down.

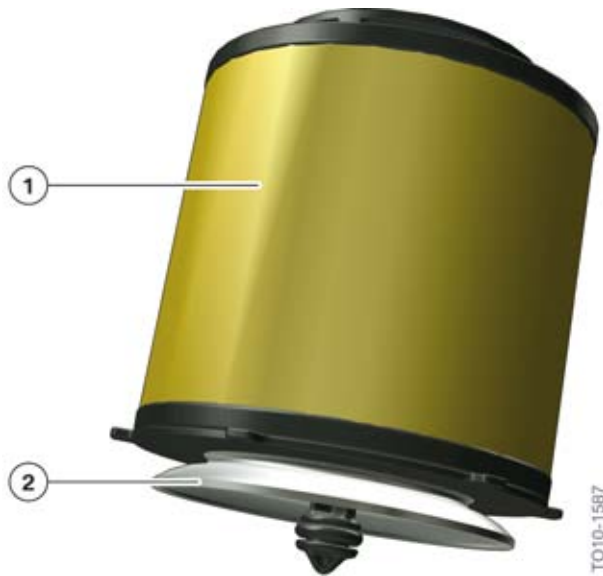

N20 engine, oil filter

Index	Explanation
1	Oil filter
2	Non-return diaphragm

The non-return diaphragm is made of rubber and is raised by the oil pressure to admit oil into the filter. When the engine is shut down and the oil pressure drops, the non-return diaphragm uses its shape and elasticity to seal off the oil duct. The engine oil is unable to flow out of the filter. The non-return diaphragm is part of the oil filter and is therefore automatically replaced each time the filter is changed.

The N20 engine has a filter bypass valve which can open a bypass around the filter if, for example, the engine oil is cold and has a higher viscosity. This occurs if the pressure difference between before and after the filter exceeds about 2.5 bar. The allowable pressure difference has been increased from 2.0 to 2.5 bar in order to protect the lead-free crankshaft and connecting rod bearings. This ensures that the filter is bypassed much less frequently and any dirt particles are reliably filtered out.

N20 Engine

3. Oil Supply

3.4. Oil monitoring

3.4.1. Oil pressure and temperature sensor



N20 engine, oil pressure and temperature sensor

A new combined oil pressure and temperature sensor is used. The pressure signal is required for oil pump map control, the temperature signal for engine heat management.

The sensor is exposed in the main oil passage to the oil pressure prevailing there and the oil temperature. Thus, what is measured is no longer the oil temperature in the oil sump, but instead the actual oil temperature in the engine.

Combined pressure and temperature sensors usually have four connections (power supply, ground, temperature signal, pressure signal). The oil pressure and temperature sensor has only three connections. The temperature and pressure signals are not transmitted on separate wires. Instead, the sensor outputs a pulse-width-modulated (PWM) signal. This PWM signal is split into three fixed cycles. The first cycle is for synchronization and diagnosis, the second transmits the temperature, and the third the pressure. The duration of the “high level” of a respective cycle determines the value.

Cycle	Function	Duration of cycle	Duration of high level
1	Synchronization and diagnosis	1024 μ s	256 – 640 μ s
2	Temperature	4096 μ s	128 – 3968 μ s
3	Pressure	4096 μ s	128 – 3968 μ s

The length of the high level is for the diagnostic signal always a multiple of 128 μ s (microsecond = 0.000001 seconds), as is shown in the table below:

Duration of high signal	Pulse width	Meaning
256 μ s	25 %	Diagnosis OK
384 μ s	37.5 %	Pressure measurement failed
512 μ s	50 %	Temperature measurement failed
640 μ s	62.5 %	Hardware fault

For this purpose the sensor is capable of self-diagnosis and can identify sensor-internal mechanical and electrical faults.

N20 Engine

3. Oil Supply

For the temperature signal:

- 128 μs (3.125 % pulse width) = -40 °C/-40 °F
- 3968 μs (96.875 % pulse width) = 160 °C/320 °F

For the pressure signal:

- 128 μs (3.125 % pulse width) = 0.5 bar (absolute)
- 3968 μs (96.875 % pulse width) = 10.5 bar (absolute)

The times indicated are nominal values. Actually the durations of each cycle and of the respective high level are measure and compared with each other. The resulting pulse width produces the respective measured value.

The actual oil pressure can be measured by installing special tool # 2 212 823. Please refer to the repair instructions.

3.4.2. Oil level monitoring

The established thermal oil level sensor is used to monitor the oil level and the oil temperature.

3.5. Oil spray nozzles

As with previous BMW engines those components which cannot be reached directly by an oil passage are lubricated and/or cooled by oil spray nozzles.

3.5.1. Piston crown cooling

The oil spray nozzles for piston crown cooling are used in the N20 engine. They incorporate a non-return valve to enable them to open and close only from a specific oil pressure.

As well as cooling the piston crowns, they are also responsible for lubricating the wrist pins, which is why it is very important for them to be precisely aligned.



N20 engine, oil spray nozzles for piston crown cooling

Opening pressure	2.5 – 2.9 bar
Closing pressure	2.1 bar

N20 Engine

3. Oil Supply



The oil spray nozzles for piston crown cooling in the N20 engine must be correctly positioned using a special tool # 2 212 829 after being installed. Refer to the repair instructions.

There are two different variants of oil spray nozzle for piston crown cooling for the N20 engine, depending on their arrangement in the engine. One variant for cylinders 1 and 3 and one variant for cylinders 2 and 4.

3.5.2. Chain drive

The chain drive in the N20 engine is divided into an upper section (the camshaft drive) and a lower section (the oil pump drive).

Camshaft drive

The timing chain is lubricated by an oil spray nozzle located in the chain tensioner. There is an opening in the tensioning rail through which the oil can be sprayed for this purpose.



N20 engine, chain tensioner with oil spray nozzle for timing chain

N20 Engine

3. Oil Supply

Counterbalance shaft and oil pump drive

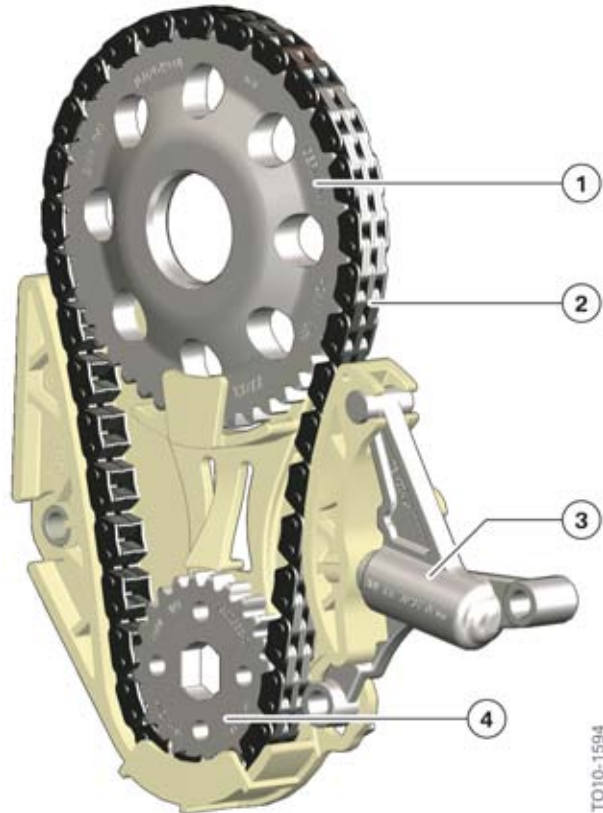

N20 engine, counterbalance shaft and oil pump drive

Index	Explanation
1	Crankshaft sprocket
2	Chain
3	Chain tensioner
4	Counterbalance shaft sprocket

Oil is sprayed onto the chain through the chain tensioner for the counterbalance shaft and oil pump drive. This is however not necessary for lubrication, since the chain is immersed in the oil sump. In this case, this helps the oil to drain from the chain tensioner.

3.5.3. Camshaft

The lobes on the camshaft are also lubricated via oil spray nozzles. For the intake camshaft there are fine grooves in the gates which are supplied with oil from the screw hole.

N20 Engine

3. Oil Supply

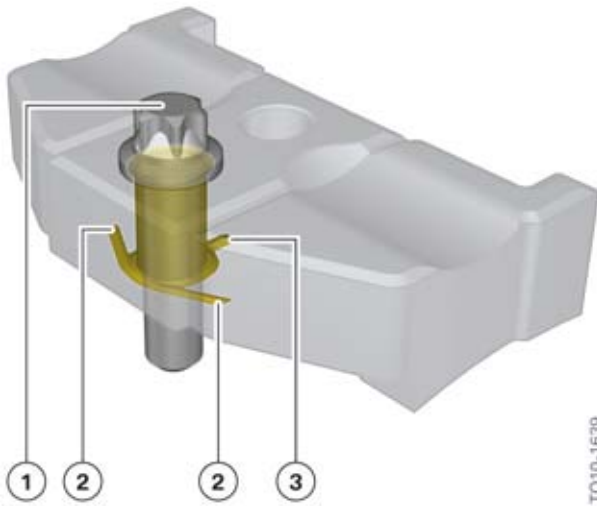

N20 engine, guide block with oil spray nozzles for intake cams

Index	Explanation
1	Screw connection, gates
2	Oil spray nozzles for intake cams
3	Oil supply for oil spray nozzles



When fitting the guide block it is essential to work in absolutely clean conditions, as any soiling could block the oil spray nozzles. Lubrication of the cam lobes would no longer be guaranteed and could result in damage to the valvetrain.

For the exhaust camshaft, the cylinder head features an oil pipe which sprays oil through small holes directly onto the cam lobes. Accordingly, there are eight holes for lubricating the exhaust valve lobes and an extra hole for lubricating the triple cam which drives the high-pressure fuel pump.

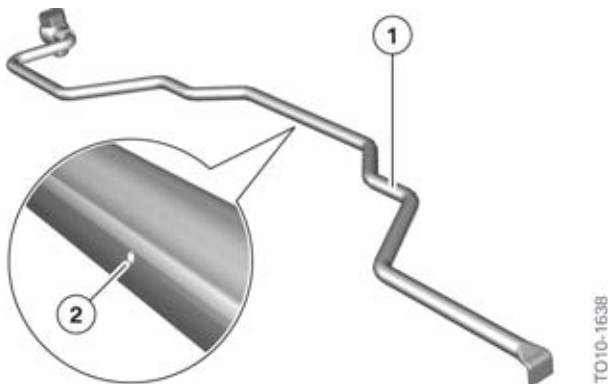

N20 engine, oil pipe with oil spray nozzles for exhaust cam lobes

N20 Engine

3. Oil Supply

Index	Explanation
1	Oil pipe
2	Hole

3.5.4. Gearing, Valvetronic servomotor



N20 engine, oil spray nozzle for Valvetronic servomotor

The N20 engine features the same Valvetronic servomotor as the N55 engine including the same installation position. The worm gear for adjusting the eccentric shaft is also lubricated by an oil spray nozzle. This nozzle must be correctly aligned when fitted. However, this does not require the use of a special tool. Instead the nozzle has to be carefully and noticeably engaged in the designated guide on the Valvetronic servomotor.

N20 Engine

3. Oil Supply

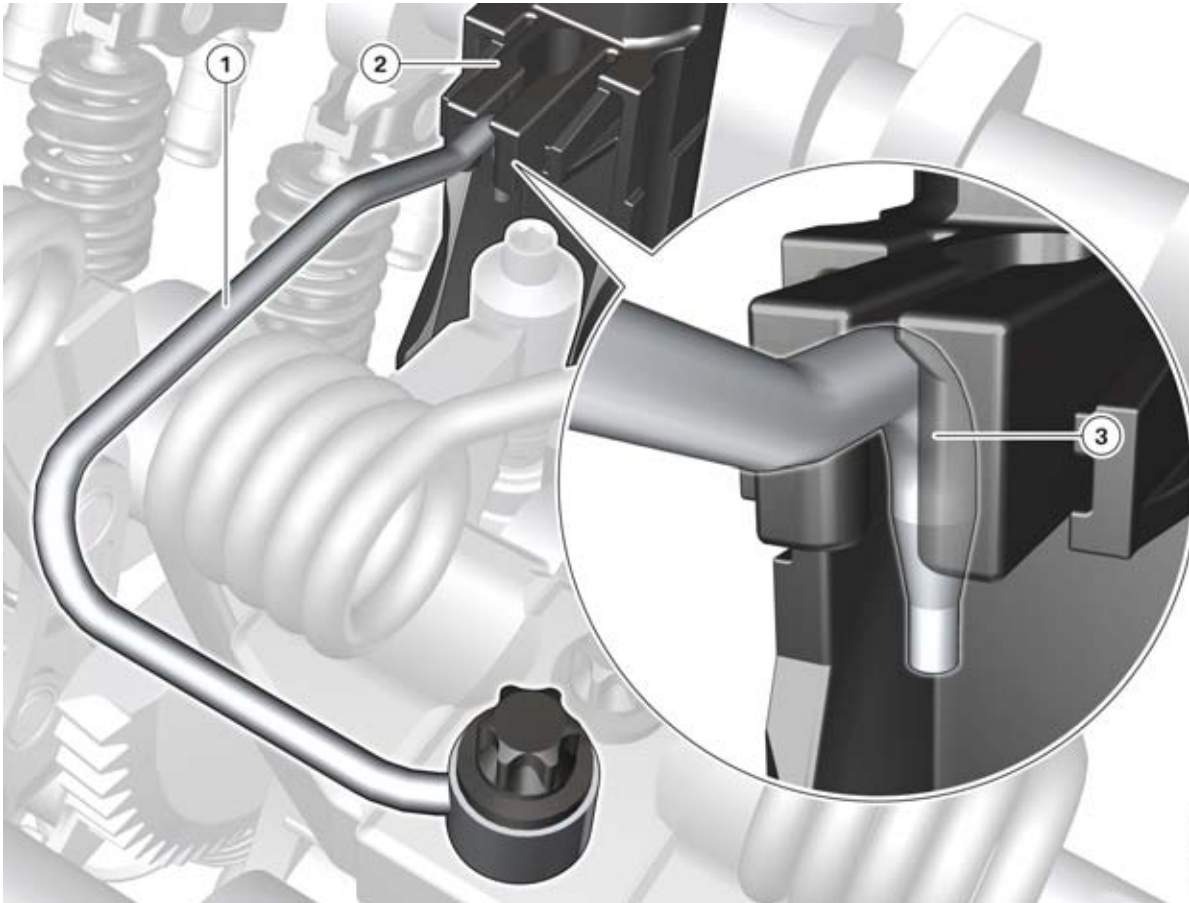

N20 engine, engaged oil spray nozzle for Valvetronic servomotor gearing

Index	Explanation
1	Oil spray nozzle for Valvetronic servomotor gearing
2	Valvetronic servomotor
3	Correctly engaged oil spray nozzle



Due to the size of the oil spray nozzle and the fact that the motor can be assembled without the oil spray nozzle, there is the danger of it being forgotten during fitting.

Make sure when fitting the oil spray nozzle that it is correctly positioned and engaged. An incorrectly engaged oil spray nozzle will be subjected to vibrations and may break. Refer to the repair instructions.

N20 Engine

4. Cooling

The cooling system is very similar to the N55 engine. In the N20 engine an engine oil-to-coolant heat exchanger is used to cool the engine oil. The cooling system is controlled (e.g. electric coolant pump, map thermostat and electric fan) by the heat management coordinator in the DME.

4.1. Overview

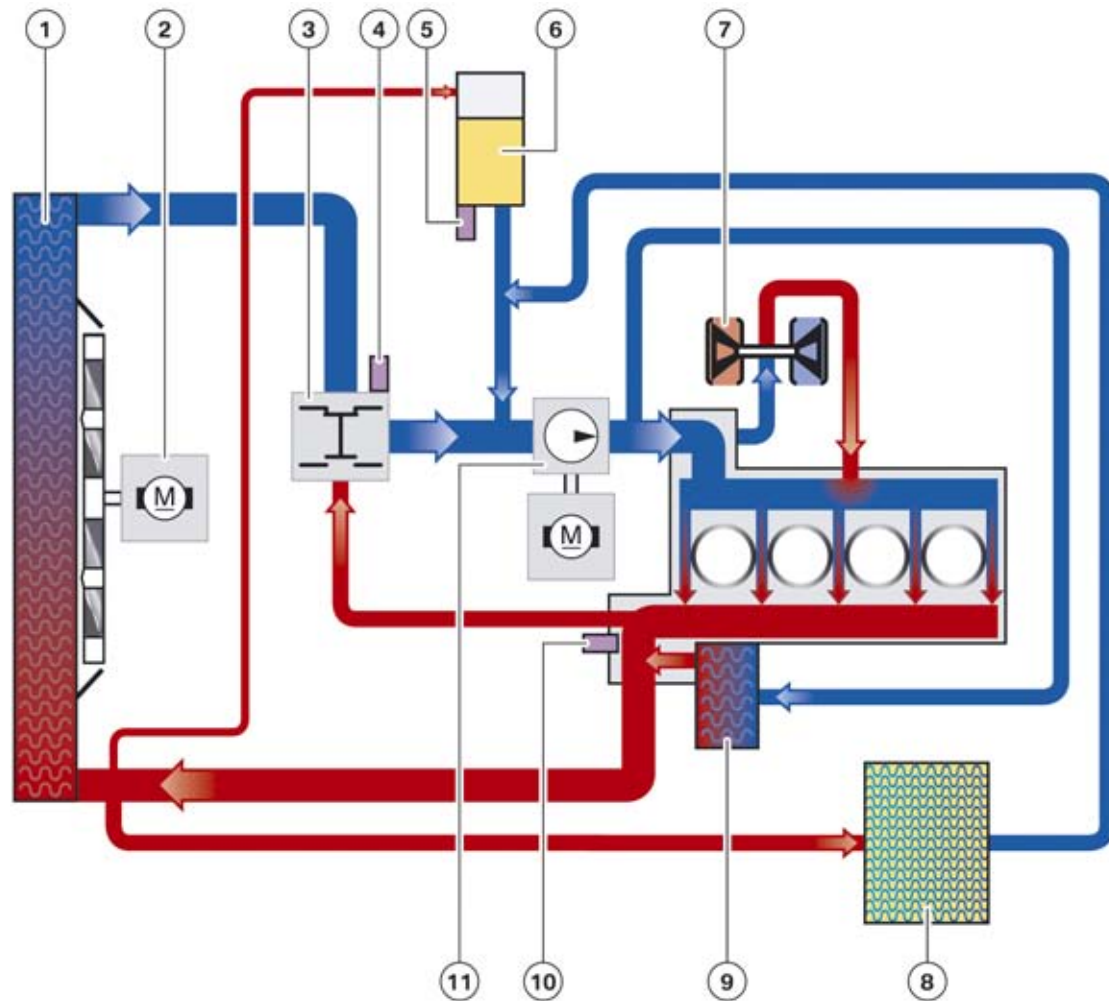

N20 engine, cooling circuit

Index	Explanation
1	Radiator
2	Electric fan
3	Map thermostat
4	Heater for map thermostat
5	Fill level sensor in expansion tank
6	Expansion tank
7	Exhaust turbocharger

TO10-1585

N20 Engine

4. Cooling

Index	Explanation
8	Heater core
9	Engine oil-to-coolant heat exchanger
10	Coolant temperature sensor
11	Electric coolant pump

The cooling module itself only comes in one variant. An auxiliary radiator (in the right wheel arch) is used in vehicles used in hot climates markets and in combination with the maximum speed optional equipment.

The electric fan has a nominal power of 600 W.

The following graphics show the installation locations and layouts of the components.

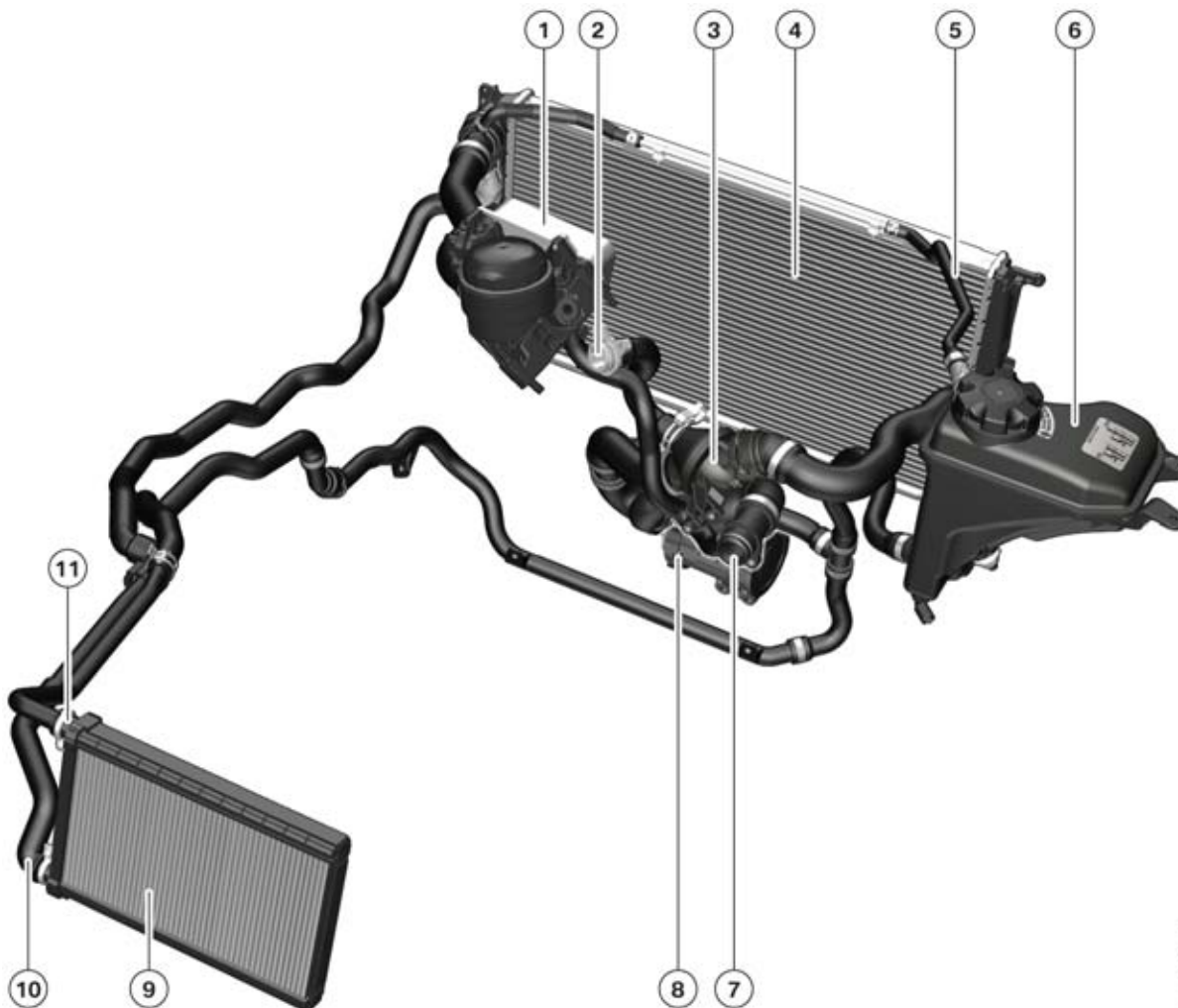

N20 engine, cooling system components from rear

TO10-1590

N20 Engine

4. Cooling

Index	Explanation
1	Engine oil-to-coolant heat exchanger
2	Engine return, bypass circuit
3	Map thermostat
4	Radiator
5	Ventilation line
6	Expansion tank
7	Engine feed
8	Electric coolant pump
9	Auxiliary radiator (not installed in all models)
10	Feed, heater core
11	Return, heater core

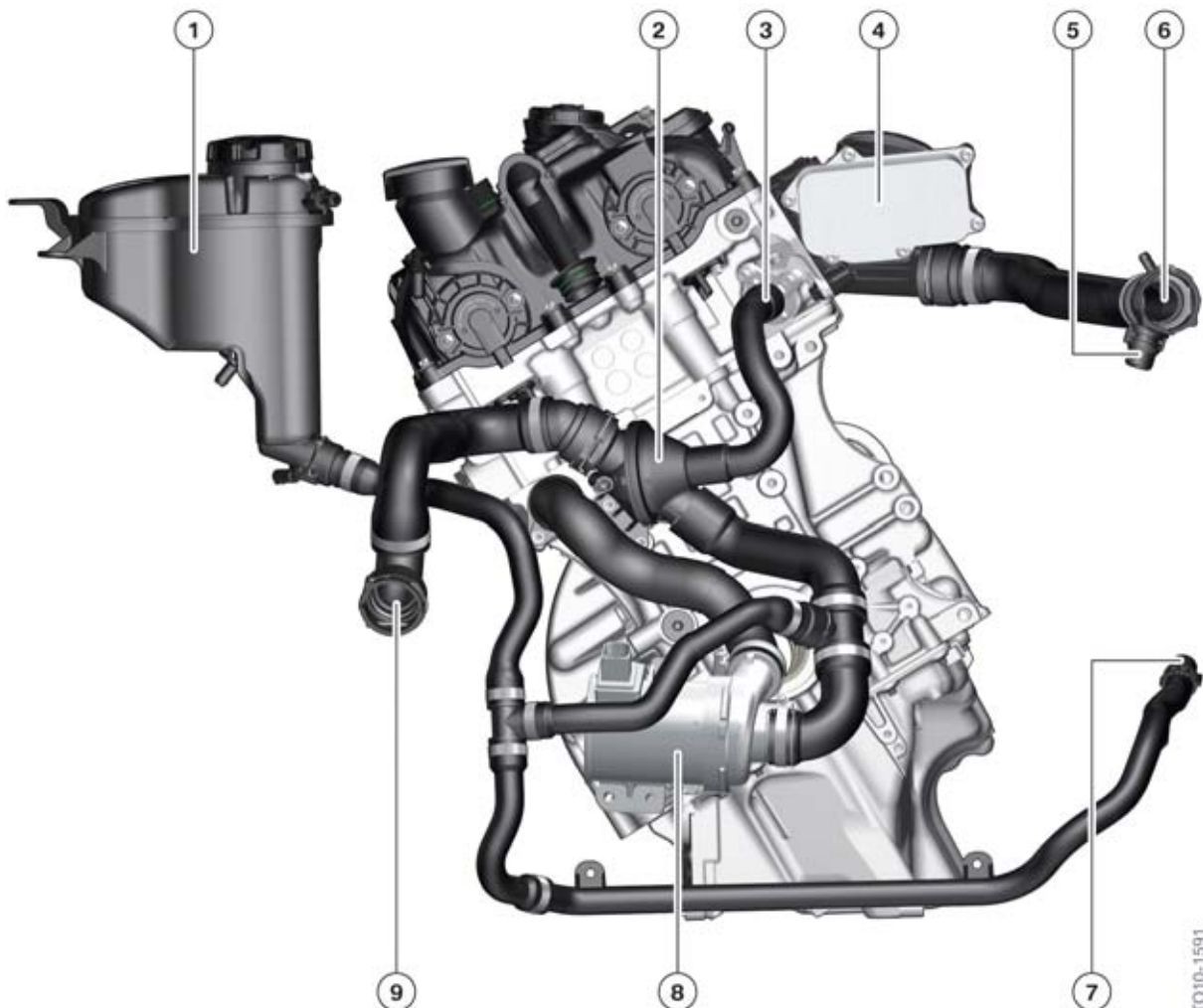

N20 engine, cooling system components on engine front view

TO10-1591

N20 Engine

4. Cooling

Index	Explanation
1	Expansion tank
2	Map thermostat
3	Engine return, bypass circuit
4	Engine oil-to-coolant heat exchanger
5	Connection, feed, heater core
6	Feed, radiator
7	Return, heater core
8	Electric coolant pump
9	Return, radiator

4.2. Heat management

The N20 engine has the same heat management functions in the DME as the N55. This allows independent control of the electric cooling components of electric fan, map thermostat and coolant pump.

4.2.1. Coolant pump

The N20 engine has an electric coolant pump, as is the case with many BMW engines. Its nominal power consumption is 400 W.



N20 engine, coolant pump



If the coolant pump is removed but is to be reused, it is important to ensure that it is set down still filled with coolant. Drying out may cause the bearings to stick. Not following this procedure can possibly cause the coolant pump not start, which in turn may result in damage to the engine.

Before installing, turn the pump impeller manually to ensure that it moves freely.

N20 Engine

4. Cooling

4.2.2. Map thermostat

The N20 engine is fitted with a conventional map thermostat which has the following technical data in non-electrically controlled mode:

Setting of map thermostat	Coolant temperature
Starts to open	97 ±2 °C / 206 ±2 °F
Fully open	109 °C / 228 ±2 °F

In addition, an electric heater in the map thermostat can be used to make the thermostat open at a lower coolant temperature.

4.2.3. Heat management function

The heat management determines the current cooling requirement and controls the cooling system accordingly. Under certain circumstances the coolant pump can even be shut down entirely, for example in order to heat the coolant more quickly in the warm-up phase. The coolant pump continues to deliver when the engine is stopped and very hot to cool the exhaust turbochargers. The cooling output can therefore be requested independently of the engine speed. In addition to the map thermostat the heat management is able to activate the coolant pump using different program maps. The engine management is thus able to adapt the coolant temperature to the driving situation.

The following temperature ranges are adjusted by the engine management:

- 109 °C / 228 ±2 °F= Economy operation
- 106 °C / 222 ±2 °F= Normal operation
- 95 °C / 203 ±2 °F= High operation
- 80 °C / 176 ±2 °F= High operation and current supply to the map thermostat.

If the engine control unit identifies the "Economy" operating range on the basis of running performance, the engine management adjusts to a higher temperature (109 °C / 228 °F). In this temperature range the engine is to be operated with a relatively low fuel requirement. Internal engine friction is reduced at higher temperature. The temperature increase therefore favors the lower fuel consumption in the low load range. In "High operation and current supply to the map thermostat" mode the driver would like to utilize the engine's optimum power development. Thus the temperature in the cylinder head is reduced to 80 °C / 176 °F for this purpose. This reduction improves volumetric efficiency, which results in an engine torque increase. The engine control unit can now (adapted to the relevant driving situation) adjust a specific operating range. It is therefore possible to influence consumption and power output via the cooling system.

System protection

If the coolant or engine oil is subject to excessive temperatures during engine operation, certain functions in the vehicle are influenced in such a way that more energy is made available for engine cooling.

The measures are split into two operating modes:

- Component protection

N20 Engine

4. Cooling

- Coolant temperature from 117 °C / 242 °F
- Engine oil temperature from 143 °C / 289 °F at the oil pressure and temperature sensor in the main oil passage
- Measure: e.g. power reduction of climate control and of engine
- Emergency
 - Coolant temperature from 122 °C / 251 °F
 - Engine oil temperature from 151 °C / 303 °F at the oil pressure and temperature sensor in the main oil passage
 - Measure: e.g. power reduction of engine (up to about. 90 %)

4.3. Internal engine cooling

As in the N55 engine, the coolant passages in the cylinder head also surround the injectors, which are cooled in this way.

Unlike the N55 engine, the N20 engine has no grooves on the block deck between the cylinders. Instead, the N20 engine has bore holes between the cylinders, two on each side, which meet in the middle.

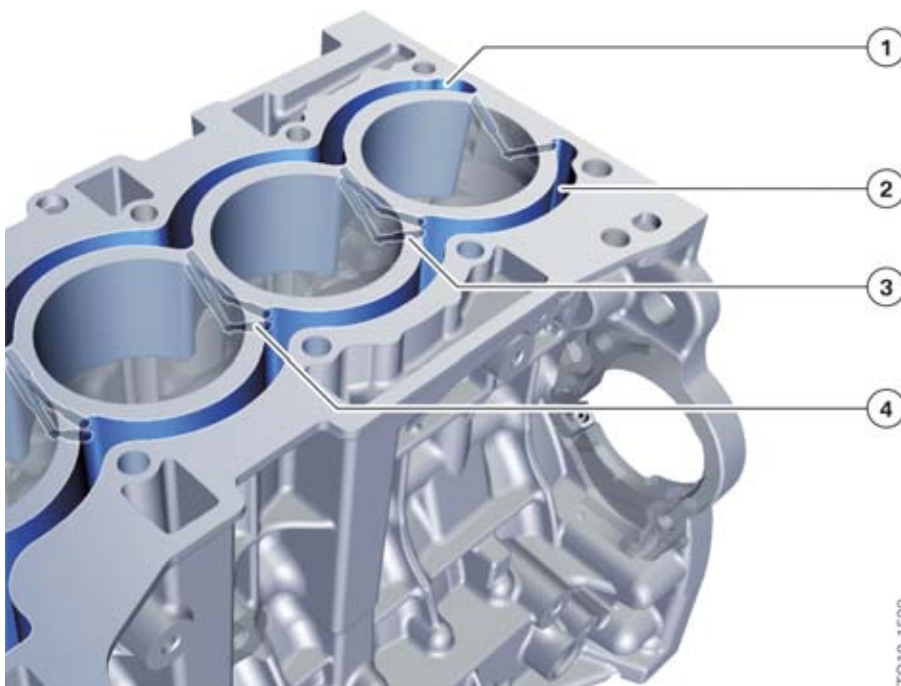

N20 engine, cooling jacket and coolant passages

Index	Explanation
1	Cooling jacket, exhaust side
2	Cooling jacket, intake side
3 + 4	Coolant passages in the lands

N20 Engine

5. Air Intake/Exhaust Emission Systems

The air intake and exhaust emission systems are in principle similar to the N55. The list below itemizes the most important features of the air intake and exhaust emission systems:

- Permanently attached intake silencer
- Hot-film air mass meter
- TwinScroll exhaust turbocharger with integrated wastegate and blowoff valves
- Three connections for crankcase ventilation

5.1. Overview

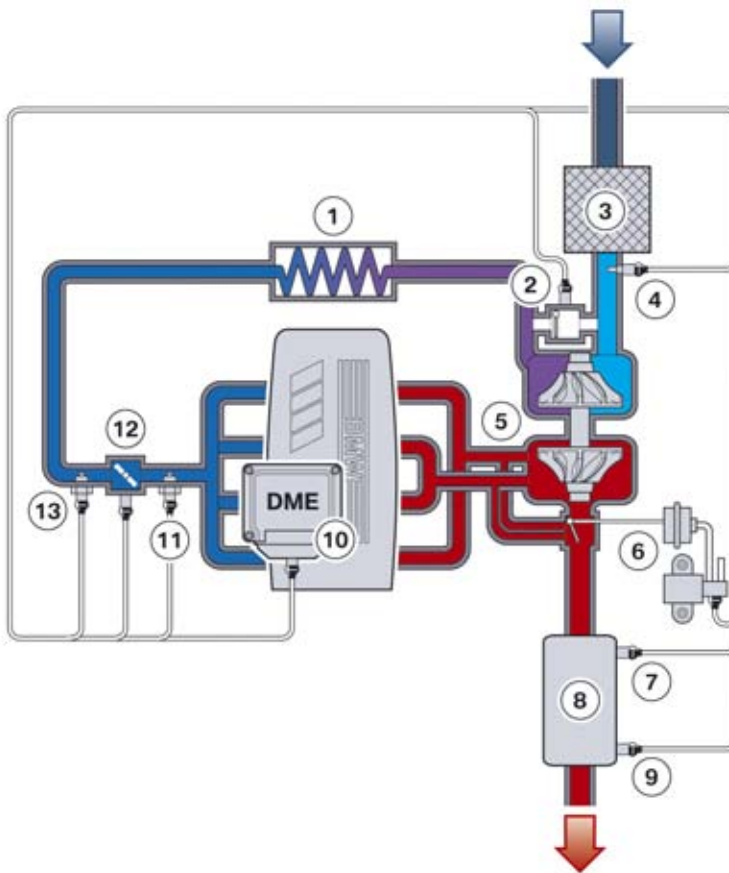

TO10-1560

N20 engine, air intake and exhaust emission systems

Index	Explanation
1	Charge air cooler
2	Blowoff valve
3	Intake silencer
4	Hot-film air mass meter
5	Exhaust turbocharger

N20 Engine

5. Air Intake/Exhaust Emission Systems

Index	Explanation
6	Wastegate valve
7	Oxygen sensor before catalytic converter
8	Catalytic converter
9	Oxygen sensor after catalytic converter
10	Digital Engine Electronics (DME)
11	Intake manifold pressure sensor
12	Throttle valve
13	Charge air temperature and pressure sensor

N20 Engine

5. Air Intake/Exhaust Emission Systems

5.2. Intake air system

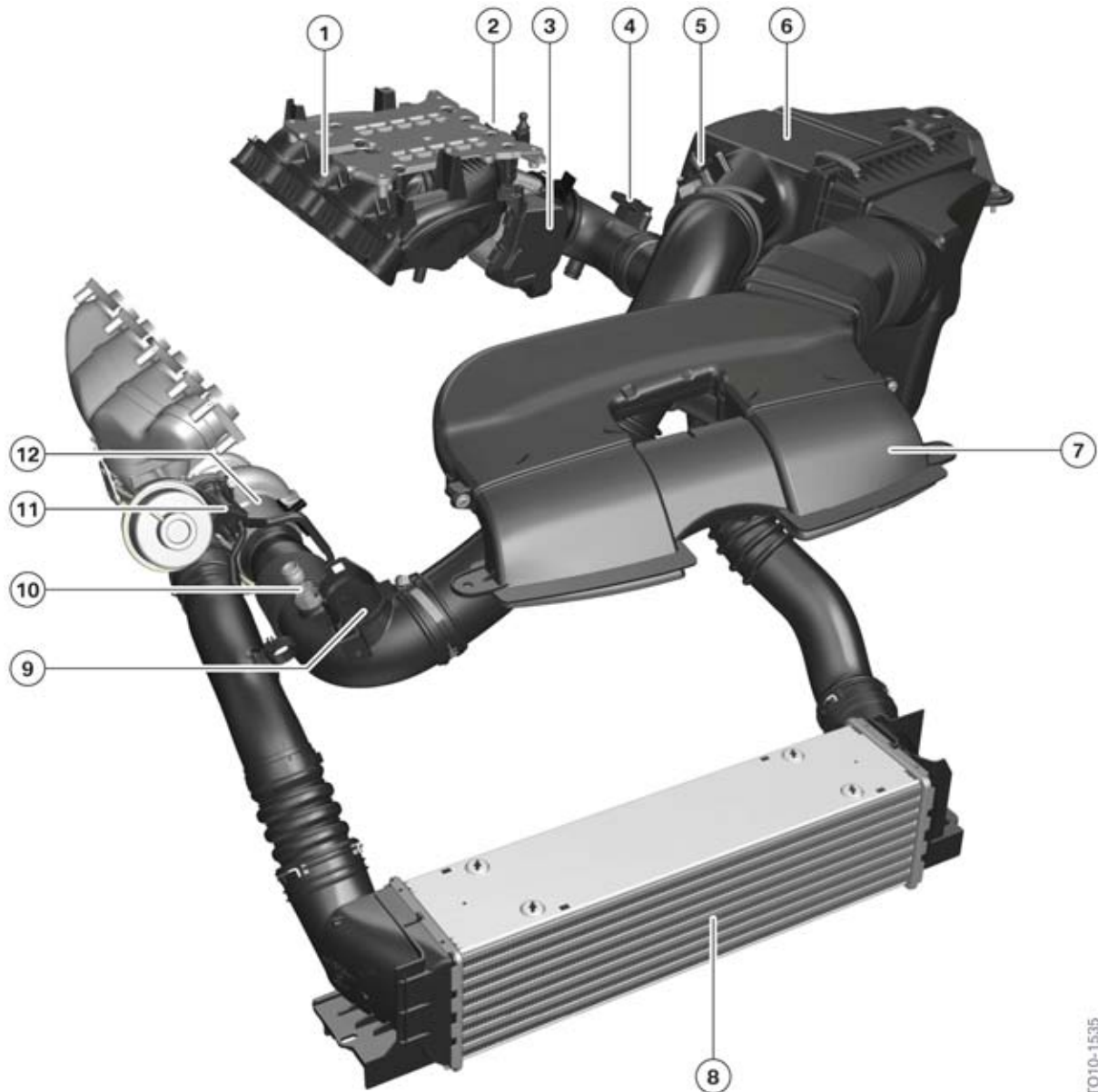

N20 engine, air intake system

TO10-1535

Index	Explanation
1	Intake manifold
2	Intake manifold pressure sensor
3	Throttle valve
4	Charge air temperature and pressure sensor
5	Hot-film air mass meter
6	Intake silencer

N20 Engine

5. Air Intake/Exhaust Emission Systems

Index	Explanation
7	Unfiltered air intake
8	Charge air cooler
9	Connection, crankcase ventilation, turbocharged mode
10	Connection, purge air line, crankcase ventilation
11	Blowoff valve
12	Exhaust turbocharger

5.2.1. Hot-film air mass meter

The N20 engine is equipped with a hot-film air mass meter, which is very similar to that in the N74 engine.

It can generally be said that the quality of air mass determination by measurement using a hot-film air mass meter and by calculation of the substitute value (of intake air temperature, charging pressure, engine speed, etc.) is to be considered as equal in the current state of development. The calculated substitute value is nevertheless used for engine load control. This value is however regularly adjusted with the value of the hot-film air mass meter in order to compensate for tolerances which arise on account of the complex flow conditions in the air intake system. The more sophisticated the mixture preparation method (Valvetronic, High Precision Injection (especially in conjunction with stratified charge mode), TVDI), the more important it is to adjust the substitute value with the hot-film air mass meter. TVDI is currently the most sophisticated mixture preparation method. For this reason, all TVDI engines are also equipped with a hot-film air mass meter.

The use of a hot-film air mass meter also offers the opportunity of extended diagnostics, e.g. for tank or crankcase ventilation, as these systems create a deviation in the air mass that can be interpreted and used to diagnose running faults.



Failure or disconnection of the hot-film air mass meter does not immediately result in emergency engine operation. However, impaired mixture preparation and therefore poorer emission values are possible, which is why the emissions warning lamp (Check Engine Light) lights up.

5.2.2. Intake manifold

As in the N55 engine, the Digital Engine Electronics (DME) is mounted on the intake manifold. However, there are differences. First, the DME is located on the intake manifold and not under it. Second, the intake manifold is not open after the DME is removed. Located between the intake manifold and the DME is a metal plate (heat sink) which conducts heat away from the DME this plate is cooled by the air flow of the intake manifold.

N20 Engine

5. Air Intake/Exhaust Emission Systems

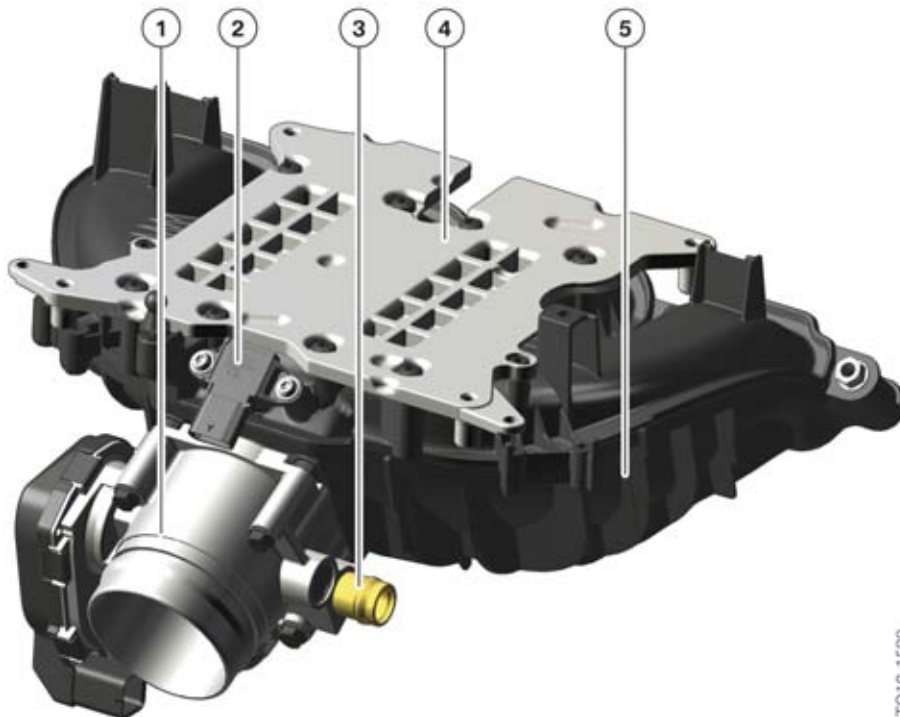

N20 engine, intake manifold with throttle valve

Index	Explanation
1	Throttle valve
2	Intake manifold pressure sensor
3	Connection from tank vent valve
4	Metal plate for accommodating the DME
5	Intake manifold

Intake manifold pressure sensor

Located directly behind the throttle valve, at the entry to the intake manifold, is the intake manifold pressure sensor. On closer inspection, it can be seen to be a combined pressure and temperature sensor. The temperature signal is therefore not read out. The reason for using this sensor lies in the concept of common parts. It is better to use the same sensor which is also used as the charge air temperature and pressure sensor and simply not to read out the temperature signal than to introduce a separate sensor.

5.3. Exhaust turbocharger

The N20 engine features an exhaust turbocharger with TwinScroll technology. It includes at the turbine inlet two separate ports in which the exhaust gas is routed from two cylinders to the turbine vanes.

N20 Engine

5. Air Intake/Exhaust Emission Systems

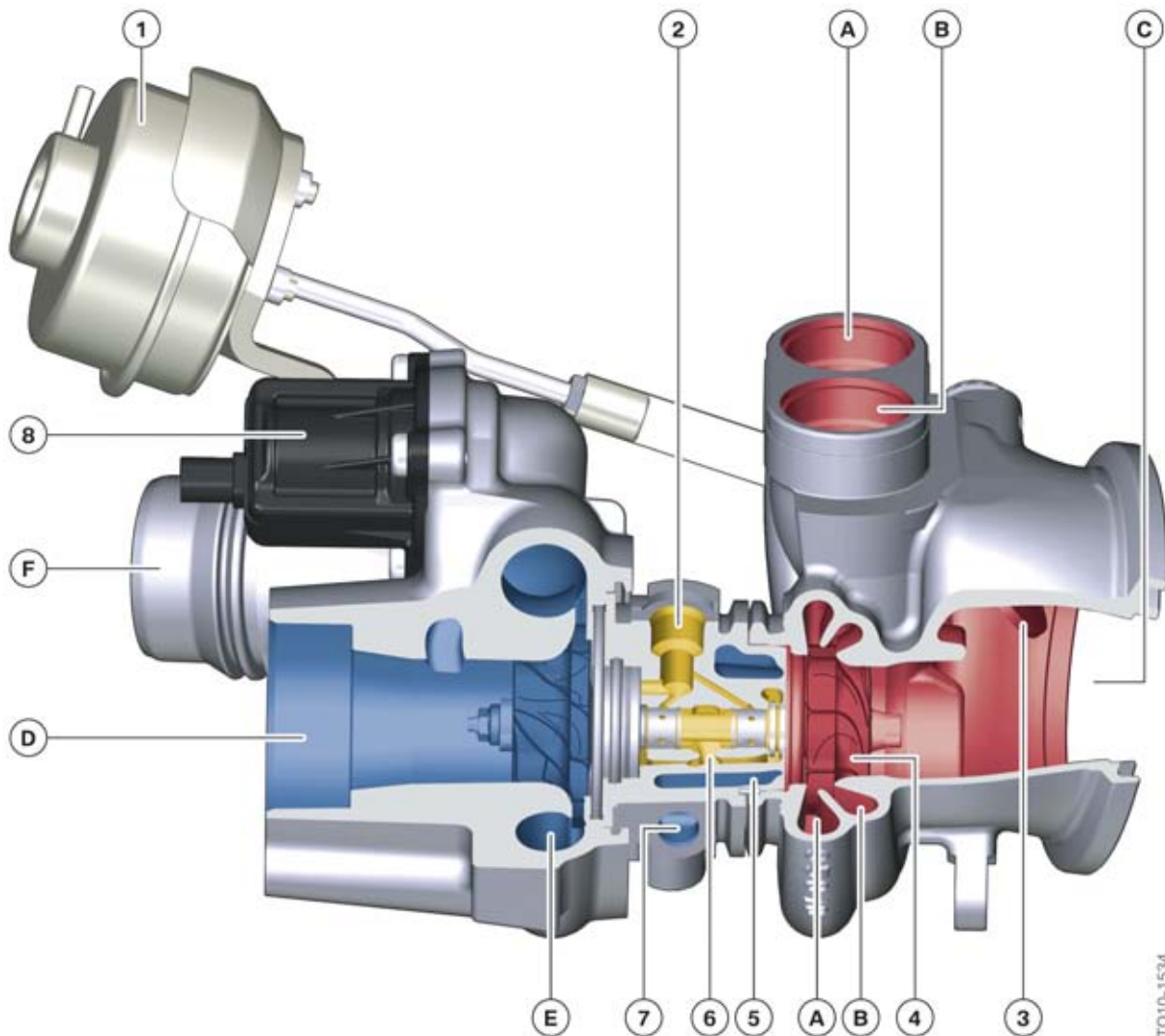

N20 engine, turbocharger

Index	Explanation
A	Exhaust port, cylinders 2 and 3
B	Exhaust port, cylinders 1 and 4
C	Outlet to catalytic converter
D	Inlet from intake silencer
E	Ring port
F	Outlet to charge air cooler
1	Vacuum unit for wastegate valve
2	Oil supply
3	Wastegate valve
4	Turbine wheel

N20 Engine

5. Air Intake/Exhaust Emission Systems

Index	Explanation
5	Cooling passage
6	Oil passage
7	Coolant return
8	Blowoff valve

The turbocharger has a familiar design with an electric blowoff valve and a vacuum-controlled wastegate valve.

5.3.1. Function of TwinScroll exhaust turbocharger

The designation TwinScroll denotes an exhaust turbocharger with a twin-scroll turbine housing. The exhaust gas from two cylinders in each case is routed separately to the turbine. In the N20 engine (as is usual in 4-cylinder engines) cylinders 1 and 4 and cylinders 2 and 3 are brought together to form two ports each feeding one scroll. This results in pulse charging which is used to greater effect.

Pressure and pulse charging

Two principles of forced induction are used in engines with exhaust turbochargers – pressure and pulse charging. Pressure charging means that the pressure ahead of the turbine is approximately constant. The energy which drives the exhaust turbocharger is obtained from the pressure difference before and after the turbine.

In the case of pulse charging, the pressure before the turbine is high-speed and greatly fluctuating, or pulsating by the discharge of the exhaust gas from the combustion chamber. The pressure increase results in a pressure wave which strikes the turbine. In this case, the kinetic energy of the exhaust gas is used, whereby the pressure waves drive the turbocharger.

Pulse charging provides for a fast response by the turbocharger, especially at low speeds, because pulsation is at its strongest here, whereas in the case of pressure charging the pressure difference between before and after the turbine is still low.

In actual fact, both principles are always used in exhaust turbochargers in passenger car engines. The proportion of pulse charging is higher or lower, depending on the size factors, the exhaust port guides and the number of cylinders.

Dependence on the number of cylinders

In a single-cylinder engine there is an exhaust cycle every two revolutions of the crankshaft. Theoretically, exhaust gas is therefore discharged for 180° every 720° crank angle. The graphic below shows **in highly simplified form** the pressure conditions before the exhaust turbocharger in a single-cylinder engine.

N20 Engine

5. Air Intake/Exhaust Emission Systems

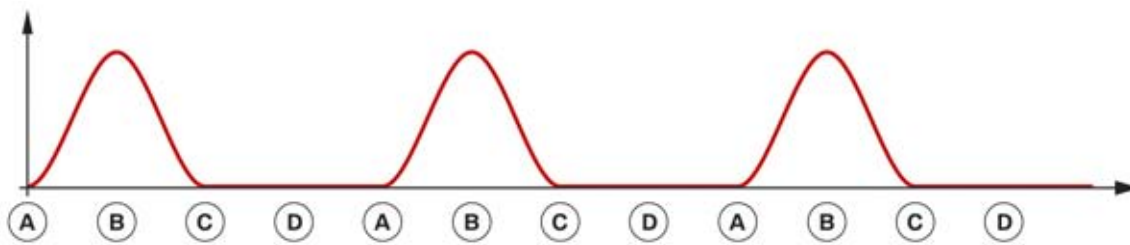

TO10-1581

Pressure diagram in exhaust port before the turbocharger in a 1-cylinder engine

Index	Explanation
A	Bottom dead center, exhaust valve opens
B	Top dead center, exhaust valve closes, intake valve opens
C	Bottom dead center, intake valve closes
D	Top dead center, ignition

As can be seen here, every 720° CA there is a pressure wave which strikes the turbine. This pulse accelerates the turbine.

The next graphic shows the pressure conditions before the turbine in a 4-cylinder engine.

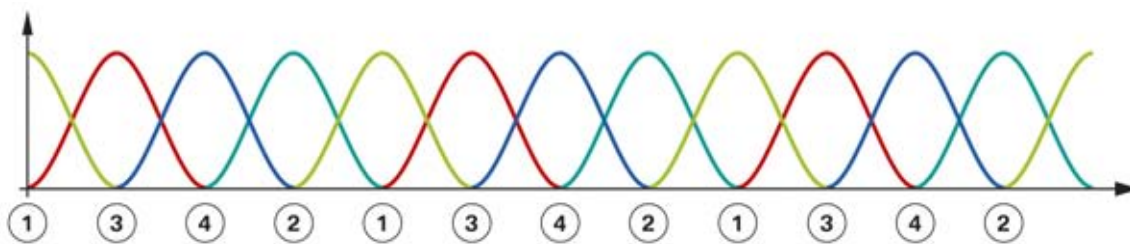

TO10-1583

Pressure diagram in exhaust port before exhaust turbocharger in a 4-cylinder engine

Index	Explanation
1	Exhaust valve, 1st cylinder, opens
2	Exhaust valve, 2nd cylinder, opens
3	Exhaust valve, 3rd cylinder, opens
4	Exhaust valve, 4th cylinder, opens

Because each cylinder had its exhaust cycle after two full crankshaft revolutions, there are four pressure waves within the 720° CA. Because of the firing interval, they are distributed evenly at an interval of 180° CA. The pressure waves are superimposed here. While the pressure of one cylinder decreases, the pressure of the next cylinder is already increasing.

This produces a superimposed pressure before the turbine, as the next graphic shows.

N20 Engine

5. Air Intake/Exhaust Emission Systems

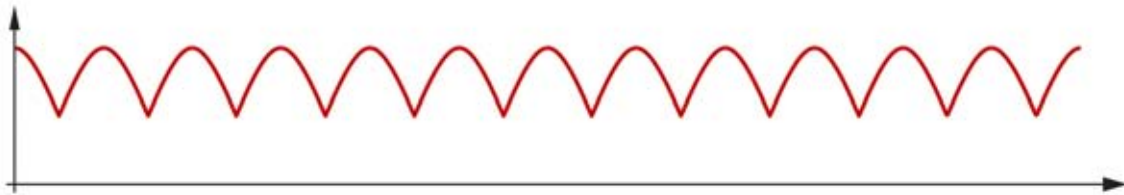

TO10-1584

Pressure diagram in exhaust port before the turbocharger in a 4-cylinder engine, superimposed

Because they are superimposed, the pressure difference from minimum to maximum is clearly lower. In this way, the pulse by the pressure wave on the turbine also decreases. In this cases, the proportion of pulse supercharging in the exhaust turbocharger is lower.

One way of preventing this in a 4-cylinder engine is the TwinScroll exhaust turbocharger. By splitting the four cylinders into two ports, the pressure conditions of a 2-cylinder engine are depicted in the two ports in each case, as the following graphic shows.

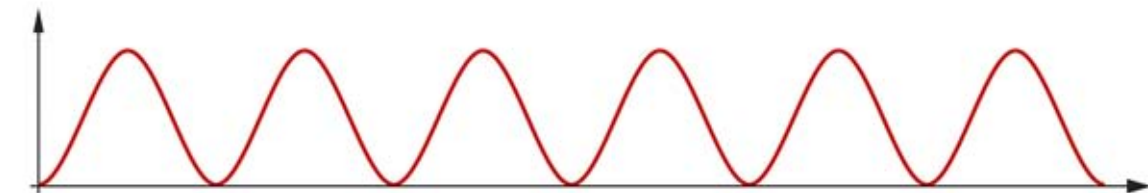
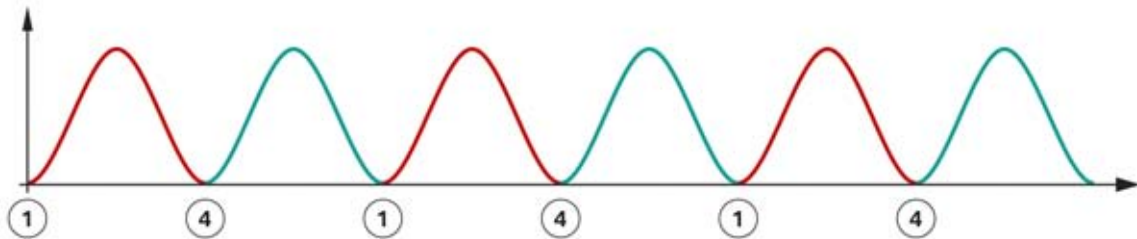

TO10-1582

Pressure diagram in exhaust port before the turbocharger in a 4-cylinder engine, individually and superimposed

Index	Explanation
1	Exhaust valve, 1st cylinder, opens
4	Exhaust valve, 4th cylinder, opens

Here too the pressures of the two cylinders are superimposed. However, cylinders 1 and 4 and 2 and 3 are combined in the two ports. Because of the firing order of a 4-cylinder engine, there is in each case an interval of 360° CA between the exhaust cycles of a port. Thus there is a large pressure difference and the kinetic energy of the exhaust gas can be better utilized.

A specially shaped exhaust manifold is used to combine the exhaust pipes from cylinders 1 and 4 and 2 and 3.

In the turbocharger these two ports run separately from each other up to the turbine. The TwinScroll exhaust turbocharger differs from a conventional exhaust turbocharger in that the turbine housing separates in two forming a ring channel around the turbine.

N20 Engine

5. Air Intake/Exhaust Emission Systems

5.4. Exhaust emission system

5.4.1. Exhaust manifold

The exhaust manifold is identical in design to that of the N55 engine. It is air-gap-insulated and welded to the turbocharger. The exhaust manifold in the N20 engine is a four-into-two type, which is necessary for the special function of the TwinScroll turbocharger. Here the exhaust outlet pipes of cylinders 1 and 4 and 2 and 3 are combined in each case into one port as previously discussed.

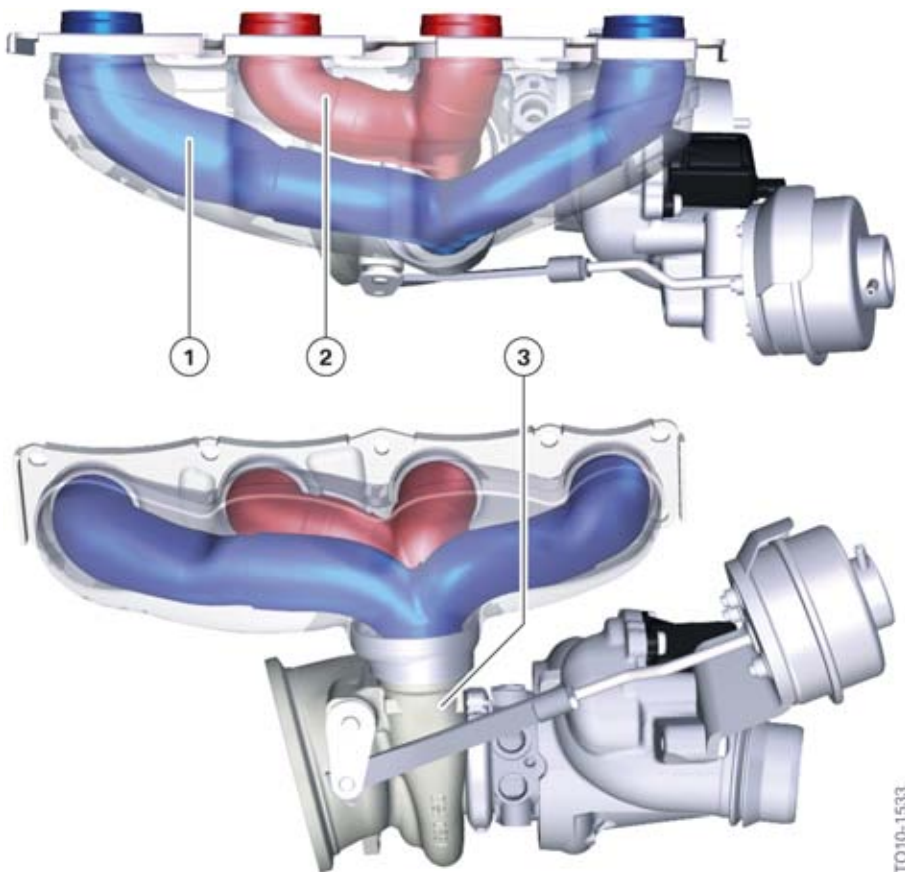

N20 engine, exhaust manifold with exhaust turbocharger

Index	Explanation
1	Exhaust ports, cylinders 1 and 4
2	Exhaust ports, cylinders 2 and 3
3	Exhaust turbocharger

5.4.2. Catalytic converter

The N20 engine has an upstream catalytic converter with two ceramic monoliths.

N20 Engine

5. Air Intake/Exhaust Emission Systems

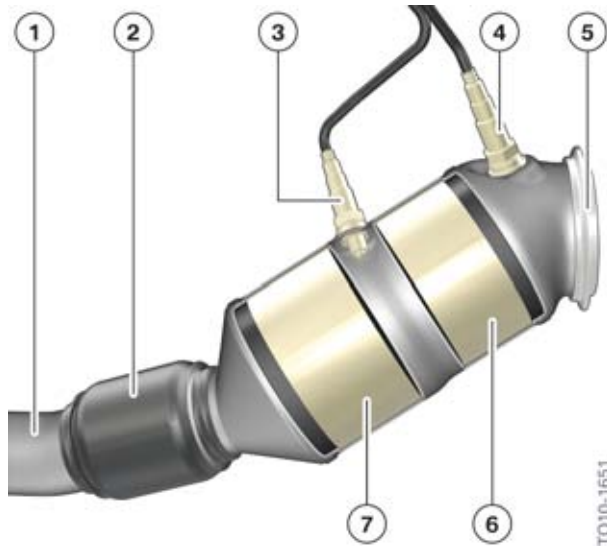

Cutaway view of catalytic converter

Index	Explanation
1	Connection to exhaust system
2	De-coupling element
3	Monitoring sensor
4	Control sensor
5	Connection to turbine
6	Ceramic monolith 1
7	Ceramic monolith 2

	Volume	Diameter	Number of cells
Ceramic monolith 1	0.75	118.4	600
Ceramic monolith 2	0.99	125	400

Oxygen sensors

The Bosch oxygen sensors used are familiar from previous engines:

- Pre oxygen sensor: LSU ADV
- Post oxygen sensor: LSF4.2.

The pre oxygen sensor is located ahead of the primary catalytic converter, as close as possible to the turbine outlet. Its position has been chosen so that all the cylinders can be recorded separately. The post oxygen sensor is positioned between the first and second ceramic monoliths.

N20 Engine

6. Vacuum System

The vacuum system of the N20 engine is comparable with that of the N55 engine. As well as supplying the brake servo, it is needed primarily to activate the wastegate valve on the turbocharger. In addition, the exhaust flap is actuated by vacuum in the N20 engine.



TO10-1641

N20 engine, vacuum system

Index	Explanation
1	Connection, brake servo
2	Vacuum pump
3	Connection, exhaust flap
4	Vacuum reservoir
5	Electro-pneumatic pressure converter for wastegate valve
6	Vacuum unit, wastegate valve

N20 Engine

6. Vacuum System

The vacuum pump as usual is designed to have two stages so that the majority of the generated vacuum is made available to the brake servo. A vacuum reservoir is used to provide sufficient vacuum for actuating the wastegate valve. This reservoir is built into the engine cover.



Disconnect the vacuum line before removing the engine cover, as otherwise there is a risk of damage.

N20 Engine

7. Fuel Preparation

The N20 engine uses high-pressure injection, which was introduced in the N55 engine. It differs from high-precision injection (HPI) in that it uses solenoid valve injectors with multi-hole nozzles instead of the piezoelectric type.

7.1. Overview

The following overview shows the fuel preparation system of the N20 engine. It essentially corresponds to the systems with direct fuel injection familiar in BMW models.

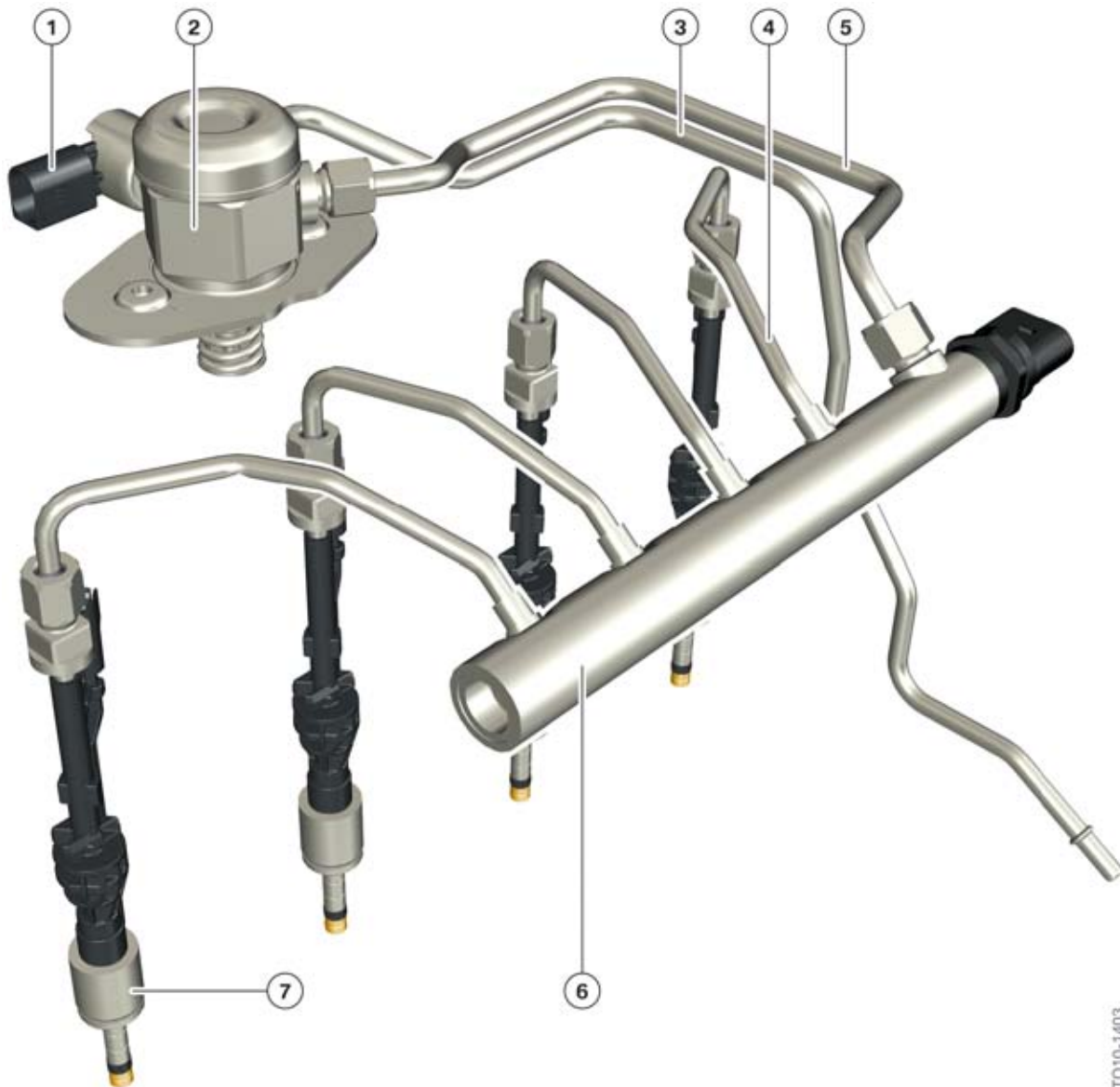

N20 engine, fuel preparation

TO10-1403

N20 Engine

7. Fuel Preparation

Index	Explanation
1	Connection, quantity control valve
2	High-pressure pump
3	Low-pressure line
4	High-pressure line, rail - injector
5	High-pressure line, high-pressure pump - rail
6	Rail
7	Solenoid valve injector

Bosch high-pressure fuel injectors with the designation HDEV5.2 are used. The high pressure pump is already known from the 8 and 12 cylinder engines. An innovation in the N20 engine is the fact that the high-pressure lines from rail to injector are now no longer screwed at the rail end, but welded. Another feature when compared with established BMW fuel systems is the omission of the fuel low-pressure sensor.



Work on the fuel system is only permitted after the engine has cooled down. The coolant temperature must be below 40 °C / 104°F, to avoid risk of injury due to spray back from residual pressure in the high-pressure fuel system.

When working on the high-pressure fuel system, it is essential to adhere to conditions of absolute cleanliness and to observe the work sequences described in the repair instructions. Even the slightest contamination and damage to the threaded fittings of the high-pressure lines can cause leaks.

When working on the fuel system of the N20 engine, it is important to ensure that the ignition coils are not wet with fuel. The resistance of the insulating silicone material is greatly reduced by sustained contact with fuel. This may result in arcing on the spark plug connection and thus in misfires.

- Before making any modifications to the fuel system, remove the ignition coils and protect the spark plugs by covering with a cloth
- Before reinstalling the solenoid valve injectors, remove the ignition coils and ensure that the cleanest possible conditions are maintained.
- Ignition coils heavily saturated by fuel must be replaced.

7.2. Fuel pump control

As already mentioned, there is no fuel low-pressure sensor in the N20 engine. The fuel pressure is calculated by monitoring pump speed and load.

7.3. High-pressure pump

The Bosch high-pressure pump, familiar from the N63 and N74 is used. This is a single-plunger pump which is driven from the exhaust camshaft via a triple lobe on the cam.

N20 Engine

7. Fuel Preparation

For further information on the high-pressure pump, please refer to the N63 and N74 engine training information available on TIS and ICP.

7.4. Injectors

The Bosch HDEV5.2 solenoid valve injector is an inward-opening multi-hole valve unlike the outward-opening piezo injector used in HPI engines. The HDEV5.2 is also characterized by high variability with regard to spray angle and spray pattern, and is configured for a system pressure of up to 200 bar.

These injectors are already used in the N55 engine. However, their operating principle is the same as that of the injectors used in the N73 engines.

Note: The N73 HDEV control modules contain pulse width modulated final output stages with high performance capacitors to transform the system voltage up to 85 to 100 volts. See ST042 E65 Complete Vehicle /N73 engine training material available on TIS and ICP.

N20 Engine

7. Fuel Preparation

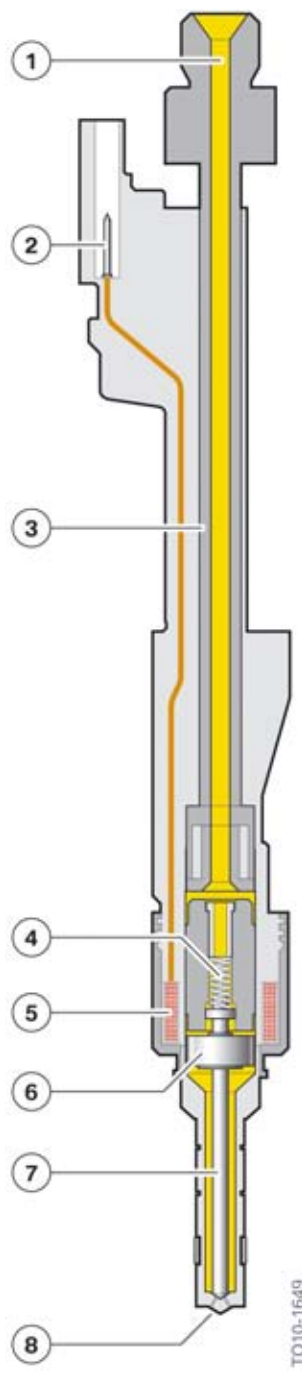

Index	Explanation
1	Fuel line connection
2	Electrical connection
3	Stem
4	Compression spring
5	Solenoid coil
6	Armature
7	Nozzle pintle
8	6-hole nozzle

A magnetic field is generated when the coil is energized. This magnetic field lifts the nozzle pintle against spring pressure off the valve seat and opens the discharge holes of the injector nozzle. The high pressure in the rail forces the fuel through discharge holes at high speed into the cylinder. To terminate injection, current is shut off, the nozzle pintle is forced closed by spring force back onto the valve seat.

N20 Engine

7. Fuel Preparation

The valve opens and closes at very high speed and ensures a constant opening cross-section during the opening period. The injected fuel quantity is dependent on the rail pressure, the back pressure in the combustion chamber and the opening period of the injector.

For further information on injector activation, refer to the section entitled Engine Electrical System of this training material.

Unlike the injectors previously used, the solenoid valve injectors of the N55 and N20 engines have long and relatively sensitive stems made necessary by the shape of the cylinder head. Each stem is made of plastic on the outside but on the inside there is a metal tube serves as a fuel line.



The stems of the solenoid valve injectors can only withstand 6Nm of torque which translates to 2000 N of tensile force. It is essential when removing and installing the injectors to follow the specific procedure set out in the repair instructions, along with the use of special tool #0 496 885 for injector removal. If this tool is not used the injectors will be damaged.

N20 Engine

8. Fuel Supply

The fuel supply is vehicle-specific. Hardly any changes have been made to the already existing models. Therefore only the tank ventilation system on the engine will be described in greater detail here.

8.1. Tank ventilation

Similar to the N55

8.1.1. Two-stage tank ventilation

The two-stage tank venting is used on the N20 engine. This sophisticated system is made necessary by the TVDI technology, because in this case sufficient vacuum in the intake manifold is much less common. This was introduced with the N55 engine.

N20 Engine

8. Fuel Supply

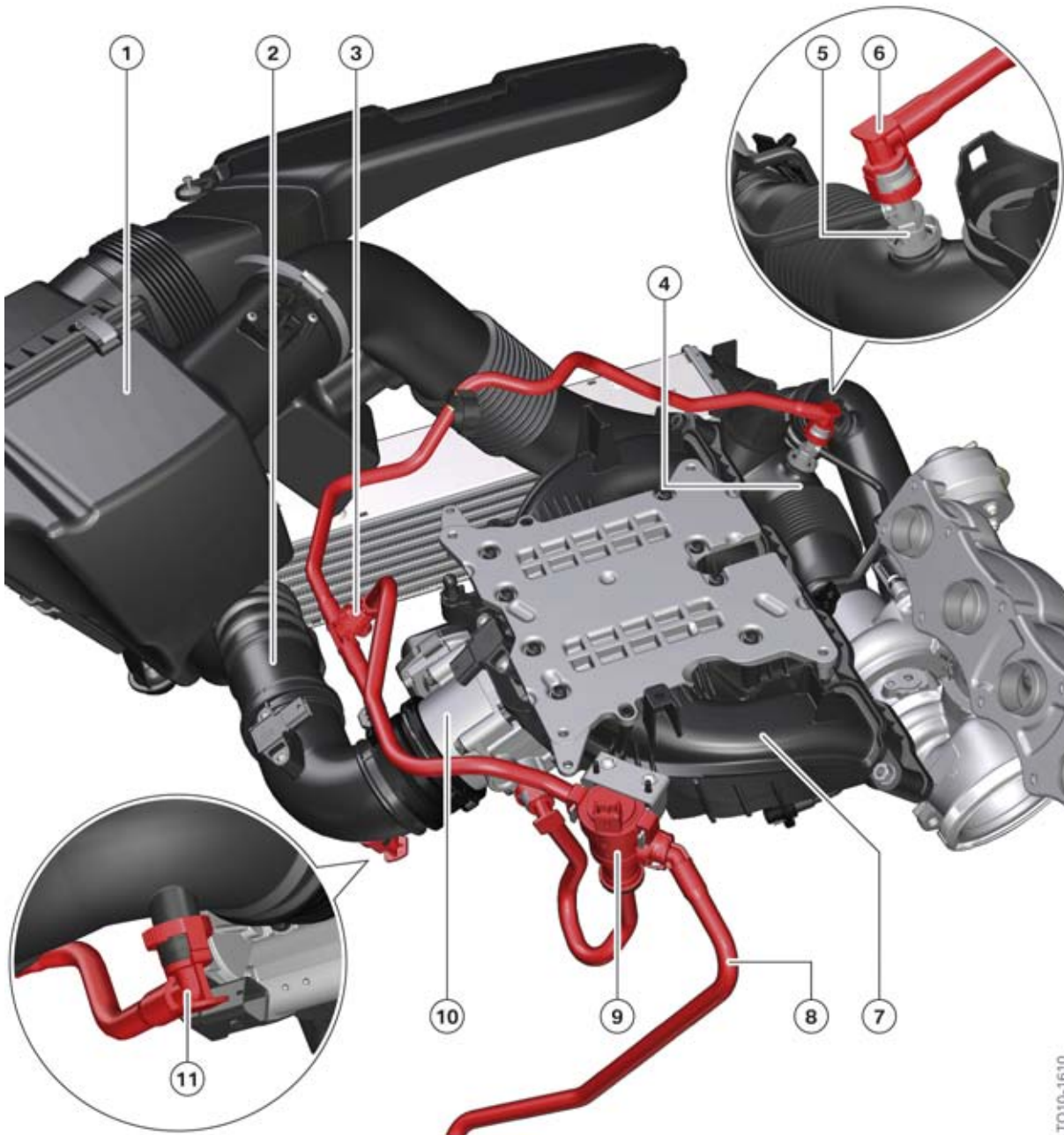

N20 engine, tank ventilation

TO10-1610

Index	Explanation
1	Intake silencer
2	Charge air pipe (from charge air cooler to throttle valve)
3	T-connector with suction jet pump
4	Clean air pipe (from intake silencer to exhaust turbocharger)
5	Connection of purge air line, crankcase ventilation

N20 Engine

8. Fuel Supply

Index	Explanation
6	Connection of tank ventilation to clean air pipe
7	Intake manifold
8	Line from carbon canister of tank ventilation system
9	Tank vent valve with shut off valve
10	Throttle valve
11	Connection before throttle valve for driving suction jet pump

However, a suction jet pump is additionally used in view of the fact that sufficient vacuum cannot always be guaranteed in the clean air pipe. In order to drive this pump, the line to the suction jet pump is connected before the throttle valve. This creates a connection between the charge air pipe and the clean air pipe. In turbocharged mode the pressure in the charge air pipe is always higher than in the clean air pipe, which generates in this line a flow to the clean air pipe.

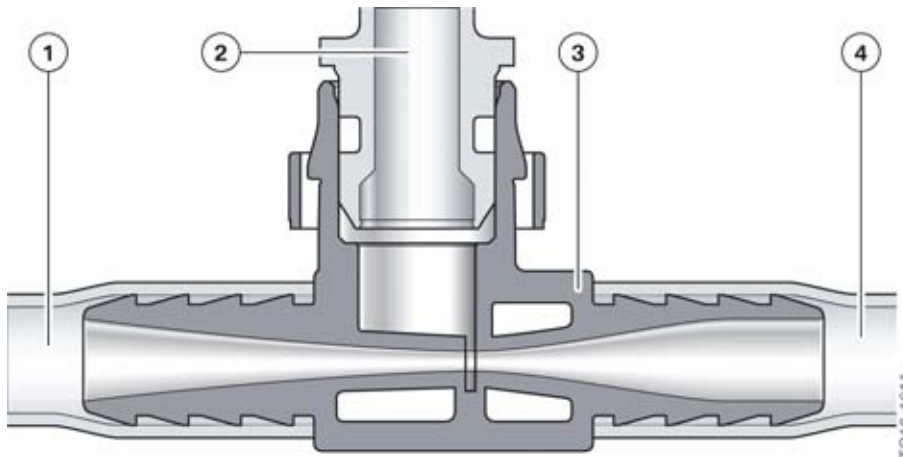

N20 engine, T-connector with suction jet pump for tank ventilation

Index	Explanation
1	Line to clean air pipe
2	Line from tank vent valve
3	T-connector with suction jet pump
4	Line from charge air pipe

The line from the tank vent valve is connected to this suction jet pump. The venturi effect ensures that the carbon canister is safely purged.

Non-return valves on both lines from the tank vent valve ensure that there is no return flow into the tank vent valve in the event of excess pressure in these lines.

8.1.2. Two-stage tank ventilation with shutoff valve

The two stage tank ventilation has a second electrical valve which is very similar in design to the tank vent valve. This is known as a shutoff valve.

N20 Engine

8. Fuel Supply

The shutoff valve serves to diagnose the second point of admission and is designed to close off the first admission into the intake manifold under certain conditions.

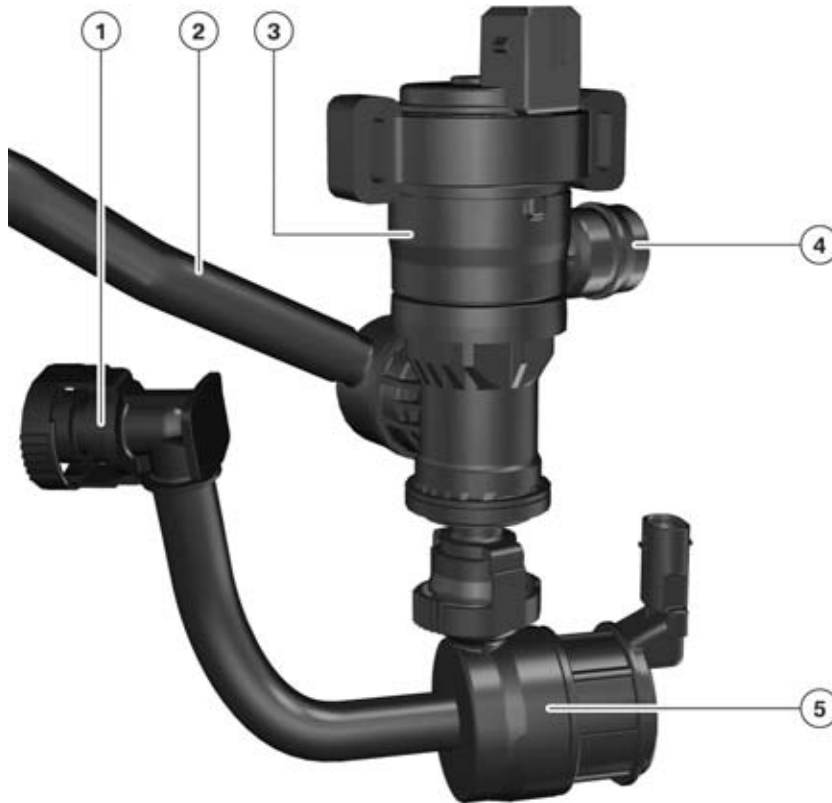

N20 engine, tank vent valve

Index	Explanation
1	Connection after throttle valve
2	Line for connection to clean air pipe
3	Tank vent valve
4	Connection from carbon canister
5	Shutoff valve

It is mounted directly below the tank vent valve and is able to seal off the line to the throttle valve.

N20 Engine

8. Fuel Supply

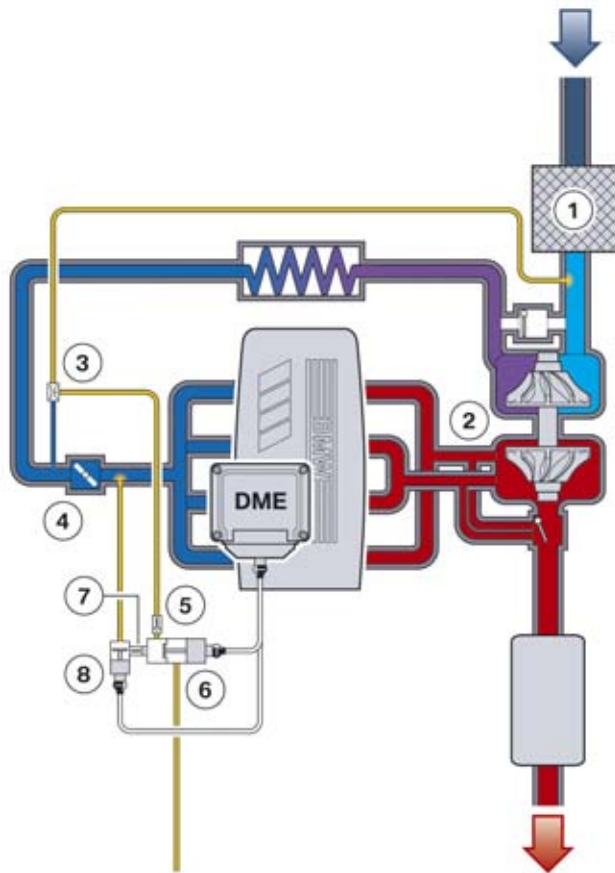

TO10-1626

N20 engine, overview, two-stage version of tank ventilation with second valve

Index	Explanation
1	Intake silencer
2	Exhaust turbocharger
3	T-connector with suction jet pump
4	Throttle valve
5	Non-return valve for connection to clean air pipe
6	Tank vent valve
7	Non-return valve for connection after throttle valve
8	Shutoff valve

The shutoff valve is powered closed and spring loaded open at zero current.

N20 Engine

9. Engine Electrical System

9.1. Overview

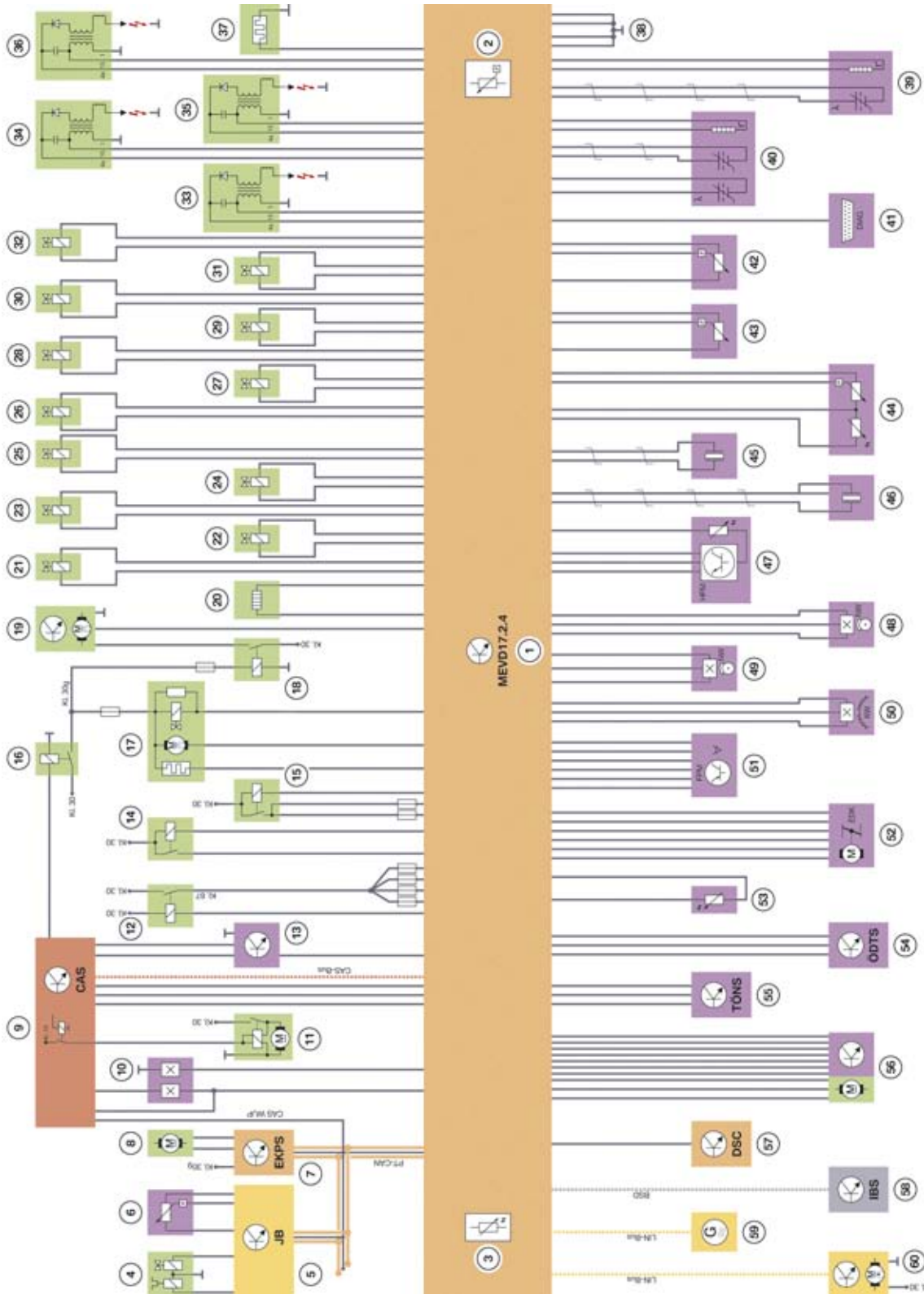

N20 Engine

9. Engine Electrical System

Index	Explanation
1	Engine electronics Valvetronic direct fuel injection MEVD17.2.4
2	Ambient pressure sensor
3	Temperature sensor
4	A/C compressor
5	Junction box electronics
6	Refrigerant pressure sensor
7	Electronic fuel pump control
8	Electric fuel pump
9	Car Access System CAS
10	Brake light switch
11	Starter motor
12	DME main relay
13	Clutch module
14	Relay, Valvetronic
15	Relay, ignition and injectors
16	Relay, terminal 30 switched
17	Diagnosis module, tank ventilation
18	Relay for electric fan
19	Electric fan
20	Map thermostat
21	Blowoff valve
22	Tank vent valve
23	VANOS solenoid actuator, intake camshaft
24	VANOS solenoid actuator, exhaust camshaft
25	Switchable engine sound system
26	Map control valve
27	Electro-pneumatic pressure converter for wastegate valve
28	Quantity control valve
29 – 32	Injectors
33 – 36	Ignition coils
37	Engine ventilation heating
38	Ground connections
39	Oxygen sensor after catalytic converter (monitoring sensor)
40	Oxygen sensor before catalytic converter (control sensor)
41	Diagnostic socket

N20 Engine

9. Engine Electrical System

Index	Explanation
42	Intake manifold pressure sensor
43	Rail pressure sensor
44	Charge air temperature and pressure sensor
45	Knock sensor 1 – 2
46	Knock sensor 3 – 4
47	Hot-film air mass meter
48	Camshaft sensor, intake camshaft
49	Camshaft sensor, exhaust camshaft
50	Crankshaft sensor
51	Accelerator pedal module
52	Throttle valve
53	Coolant temperature sensor
54	Oil pressure and temperature sensor
55	Thermal oil level sensor
56	Valvetronic servomotor
57	Dynamic Stability Control DSC
58	Intelligent battery sensor IBS
59	Alternator
60	Coolant pump

9.2. Engine control unit

The N20 engine features Digital Engine Electronics from Bosch with the designation MEVD17.2.4. It is closely related to the DME of the N55 engine (MEVD17.2) and is also engine-mounted on the intake manifold.

N20 Engine

9. Engine Electrical System

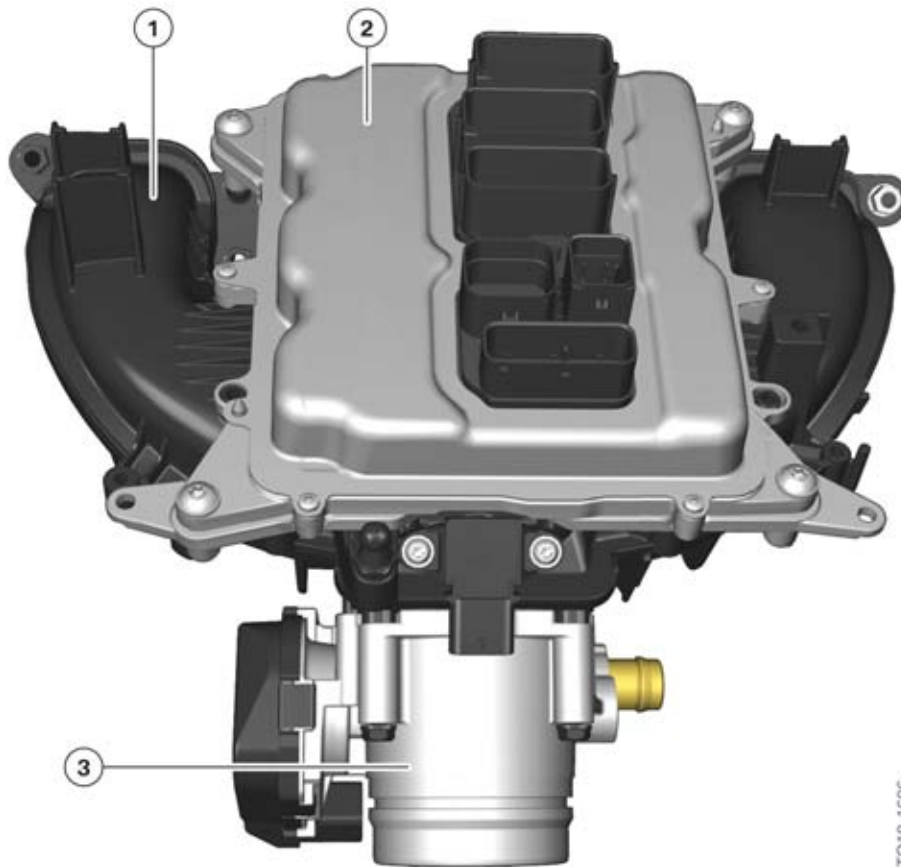

N20 engine, Digital Engine Electronics

Index	Explanation
1	Intake manifold
2	Digital Engine Electronics
3	Throttle valve



Do not attempt trial and error replacement of control units.

Because of the electronic immobilizer, a trial and error replacement of control units from other vehicles must not be attempted under any circumstances. An immobilizer adjustment cannot be reversed.

The N20 engine DME (MEVD17.2.4) is designed to be mounted on the engine's intake manifold on an aluminium heat sink plate. The DME is cooled through the heat sink plate by the air flowing through the intake manifold. It is important for the DME to be correctly mounted on the heat sink plate (tightening torque, good level contact) so as to ensure heat transfer to the plate and thereby cool the DME.

The connection concept is identical to the MEVD17.2 in the N55 engine. There is a logical division into six modules.

N20 Engine

9. Engine Electrical System

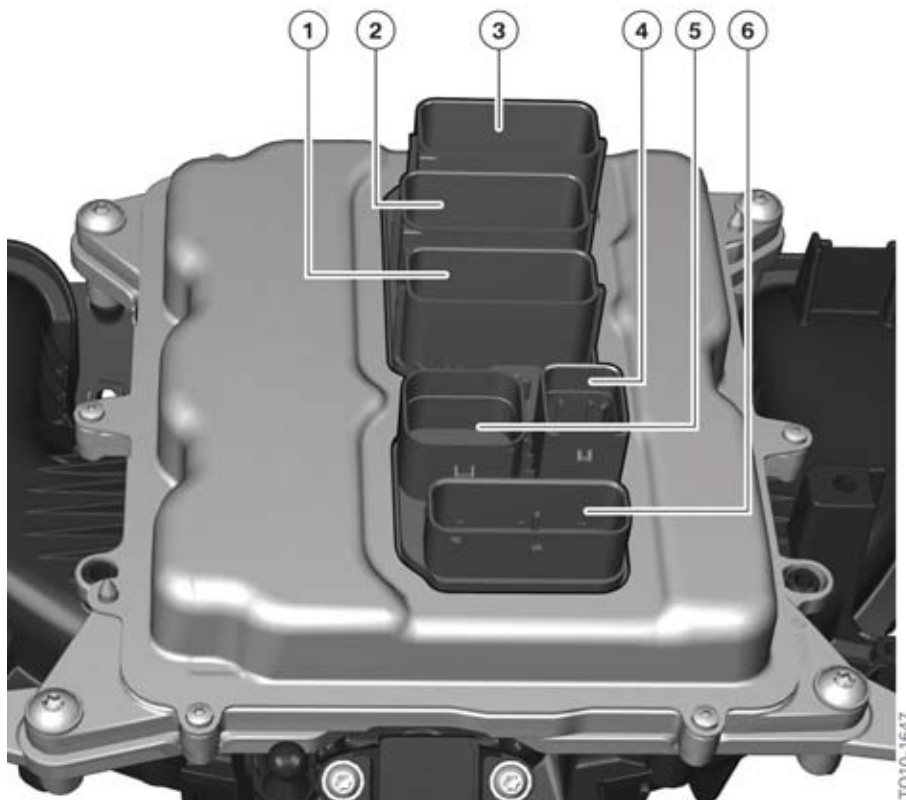

N20 engine, MEVD17.2.4 connections

Index	Explanation
1	Module 100, vehicle connection, 48 pins
2	Module 200, sensors and actuators 1, 58 pins
3	Module 300, sensors and actuators 2, 58 pins
4	Module 400, Valvetronic servomotor, 11 pins
5	Module 500, DME supply, 12 pins
6	Module 600, fuel injection and ignition, 24 pins

9.2.1. Overall function

The Digital Engine Electronics (DME) is the computing and switching center of the engine management system. Sensors on the engine and the vehicle deliver the input signals. The signals for activating the actuators are calculated from the input signals, the nominal values calculated using a computing model in the DME control unit and the stored program maps. The DME control unit activates the actuators directly or via relays.

The DME control unit is woken up via the wake-up line (terminal 15 Wake up) by the Car Access System (CAS).

N20 Engine

9. Engine Electrical System

The after-run starts after terminal 15 OFF. The adaptation values are stored during the after-run. The DME control unit uses a bus signal to signal its readiness to “go to sleep”. When all the participating control units have signalled their readiness to “go to sleep”, the bus master outputs a bus signal and the control units terminate communication five seconds later.

The printed circuit board in the DME control unit accommodates two sensors: a temperature sensor and an ambient pressure sensor. The temperature sensor is used to monitor the temperature of the components in the DME control unit. The ambient pressure is required for calculating the mixture composition.



Bayerische Motorenwerke Aktiengesellschaft
Qualifizierung und Training
Röntgenstraße 7
85716 Unterschleißheim, Germany